

Proven techniques from the
TEST PREP EXPERTS

The
Princeton
Review

Cracking the **GRE** **PREMIUM**

2015 Edition

**The All-in-One Solution for
Your Highest Possible Score**

The test-cracking techniques that revolutionized GRE prep

Drills & questions to help you practice your way to perfection

Premium online tools for the competitive edge you need

6 full-length
practice tests +
(2 full-length tests in the book & 4 online)



proven
techniques



online
video
tutorials



handy
study
guides



premium
portal
access

By Doug Pierce

GRE is a registered trademark of Educational Testing Service, which does not sponsor or endorse this product.

*The
Princeton
Review.*

Cracking the

GRE[®]

PREMIUM
2015 Edition

Doug Pierce

PrincetonReview.com



PENGUIN RANDOM HOUSE



Editorial

Rob Franek, Senior VP, Publisher
Casey Cornelius, VP, Content Development
Mary Beth Garrick, Director of Production
Selena Coppock, Managing Editor
Kristen O'Toole, Editorial Director
Calvin Cato, Editor
Meave Shelton, Editor
Alyssa Wolff, Editorial Assistant

Random House Publishing Team

Tom Russell, Publisher
Alison Stoltzfus, Publishing Manager
Ellen L. Reed, Production Manager
Dawn Ryan, Associate Managing Editor
Kristin Lindner, Production Supervisor
Andrea Lau, Designer

The Princeton Review
24 Prime Parkway, Suite 201
Natick, MA 01760
E-mail: editorialsupport@review.com

Copyright © 2014 by TPR Education IP Holdings, LLC. All rights reserved.

Cover art © OJO Images Ltd / Alamy

Published in the United States by Random House LLC, New York, and simultaneously in Canada by Random House of Canada Limited, Toronto.

A Penguin Random House Company.

Terms of Service: The Princeton Review Online Companion Tools (“Online Companion Tools”) for the *Cracking* book series and *11 Practice Tests for the SAT & PSAT* are available for the two most recent editions of each book title. Online Companion Tools may be activated only once per eligible book purchased. Activation of Online Companion Tools more than once per book is in direct violation of these Terms of Service and may result in discontinuation of access to Online Companion Tools services.

eBook ISBN: 978-1-101-88181-1

Trade Paperback ISBN: 978-0-8041-2470-6

GRE is a registered trademark of Educational Testing Services, which does not sponsor or endorse this product.

Editor: Selena Coppock

Production Editor: Jim Melloan

Production Artist: Deborah A. Silvestrini

The Princeton Review is not affiliated with Princeton University.

2015 Edition

v3.1

Acknowledgments

The following people deserve thanks for their help with this book:

Thanks to Kyle Fox for thoroughly reviewing and revising every drill and test question in the book. This update could not have happened without you.

Thanks to John Fulmer, the National Content Director for the GRE, for your hard work, unending patience, and great humor during the overhaul of this book.

Dominique Walsh, Neill Seltzer, Peter Hanink, Scott Patterson, Catherine Connell, Ellen Mendlow, Rachel Warren, Briana Gordon, Mariwyn Curtin, Katie O'Neill, Curtis Retherford, and the staff and students of The Princeton Review.

Contents

[Cover](#)

[Title Page](#)

[Copyright](#)

[Acknowledgments](#)

[...So Much More in Your Premium Portal!](#)

[Part I: Orientation](#)

[1 Introduction](#)

[2 General Strategy](#)

[Part II: How to Crack the Verbal Section](#)

3 The Geography of the Verbal Section

4 Text Completions

Practice: Finding the Clue

Practice: Clues and Triggers

Text Completions Drill

Text Completions Practice Set

5 Sentence Equivalence

Sentence Equivalence Drill

Sentence Equivalence Practice Set

6 Reading Comprehension

Reading Comprehension Drill

7 Critical Reasoning

Practice: Identifying Conclusions

Practice: Finding the Premise

Practice: Locating Assumptions

Critical Reasoning Practice Set

8 Vocabulary for the GRE

**Part III: How to Crack the
Math Section**

9 The Geography of the Math Section

10 Numbers and Equations

Numbers and Equations Drill

11 Real World Math

Real World Math Drill

12 Geometry

Geometry Drill

13 Math Et Cetera

Et Cetera Drill

Comprehensive Math Drill

Part IV: How to Crack the Analytical Writing Section

14 The Geography of the Analytical Writing Section

15 The Issue Essay

16 The Argument Essay

Part V: Answers and Explanations to Drills and Practice Sets

Part VI: The Princeton Review GRE Practice Tests and Explanations

17 Practice Test 1

[18 Answers and Explanations for
Practice Test 1](#)

[19 Practice Test 2](#)

[20 Answers and Explanations for
Practice Test 2](#)

[Appendix: Accommodated Testing](#)
[About the Authors](#)

[GRE Insider](#)

...So Much More in Your Premium Portal!



Register your book now!

- Go to PrincetonReview.com
- You'll see a welcome page where you should register your book using the ISBN. Type in 9781101881811 and create a username and password so that next time you can log into www.PrincetonReview.com easily.
- Now you're good to go!

Once you've registered, you can...

- Take 4 full-length practice GRE exams

- Plan your review sessions with study guides based on your schedule—4 weeks, 8 weeks, 12 weeks
- Watch tons of short videos in which top-notch Princeton Review teachers discuss graduate school admissions, GRE question types, strategies, and work through practice problems
- Read important opinions and advice about the GRE and graduate school
- Access crucial information about the graduate school application process, timeline, and checklist
- Access a tally of any book typos or late-breaking updates

Part I

Orientation

[1 Introduction](#)

[2 General Strategy](#)

Chapter 1

Introduction

What is the GRE? Who makes the test? What's a good score? The answer to these questions and many others lie within this chapter. In the next few pages, we'll give you the lowdown on the things you need to know about the GRE.

CRACKING THE GRE

For a lot of people, taking a standardized test such as the GRE usually engenders a number of emotions—none of them positive. But here's the good news: The Princeton Review is going to make this whole ordeal a lot easier for you. We'll give you the information you will need to do well on the GRE, including our time-tested strategies and techniques.

A few years back, the GRE was rather significantly revised. This “new” version of the test supposedly allows graduate schools to get a better sense of an applicant's ability to work in a post-graduate setting—a goal that is unrealistic indeed, considering that the people who take the GRE are applying to programs as diverse as physics and anthropology.



Strategies Galore

In this book you'll find The Princeton Review's trusted test-taking strategies to help you crack the GRE.

However, it's safe to say that neither GRE—new or old—is a realistic measure of how well you'll do in grad school, or even how intelligent you are. In fact, the GRE provides a valid assessment of only one thing:

The GRE assesses how well you take the
GRE.

Got it? Even so, you still want to do well on the GRE, because you still want grad schools to take you seriously when they consider your application. With this in mind, you should cultivate several very important skills when you're preparing for the test, and each of them is attainable with the right guidance (which we'll give you), a strong work ethic (which you must provide), and a healthy dose of optimism. Who knows? Maybe after working through this book and learning how to crack the test, you'll actually look forward to taking the GRE.

So what exactly *is* this test you've heard so much about?

WHAT IS THE GRE?

The Graduate Record Examination (GRE) is a 3-hour, 40-minute exam that's used to rank applicants for graduate schools. The scored portion of the new GRE consists of the following sections:

- One 30-minute Analysis of an Issue essay
- One 30-minute Analysis of an Argument essay
- Two 30-minute Verbal Reasoning sections
- Two 35-minute Quantitative Reasoning sections

The Verbal Reasoning sections test your skills on three different types of questions:

- Text Completion
- Sentence Equivalence

- Reading Comprehension

The Quantitative Reasoning sections measure your prowess in four areas:

- Arithmetic and Number Properties
- Algebra
- Geometry
- Data Analysis

WHY DO SCHOOLS REQUIRE IT?

Even though you will pay ETS \$185 to take the GRE, it is important to note that you are not their primary customer. Their primary customers are the admissions offices at graduate programs across the United States. ETS provides admissions professionals with two important services. The first is a number, your GRE score. Everyone who takes the test gets a number.

Applicants could come from all over the world and will certainly have an enormous range in academic and professional experience. How does one compare a senior in college with a 32-year-old professional who has been out of college working in a different industry for the past 10 years? A GRE score is the only part of the application that allows

for an apples-to-apples comparison among all applicants.

The second service that ETS provides is mailing lists. That's right; they will sell your name. You can opt out, but when you sit down to take the test, ETS will ask you a whole bunch of questions about your educational experience, family background, race, and gender, as well as other biographical data. All of this information goes into their database. In fact, ETS is one of the most important sources of potential applicants that many graduate programs have.

Another reason for the GRE is that it ensures that most applicants to graduate school are qualified. It helps to weed out the people who might be considering grad school, but who can't get their act together enough to fill out applications. It is difficult for admissions committees to make a decision between a

candidate with a 3.0 and a 3.2 GPA from drastically different schools and in two different majors. A GRE score, on the other hand, provides a quick and easy way for busy admissions offices to whittle a large applicant pool down to size. When you ask a program how important the GRE score is to the application, they may say, “it depends” or “not very” and that may be true as long as your score is in the top half. If your score is in the bottom half, however, it may mean that your application never gets seen.

So the GRE may have little relevance to any particular field of study you might be pursuing, but as long as it helps graduate programs uncover potential candidates, and as long as it is the only tool available to compare a diverse candidate pool, the GRE is here to stay.

WHO IS ETS?

Like most standardized tests in this country, the GRE is created and administered by Educational Testing Service (ETS), a big, tax-exempt, private company located in New Jersey. ETS publishes the GRE under the sponsorship of the Graduate Record Examinations Board, which is an organization affiliated with the Association of Graduate Schools and the Council of Graduate Schools in the United States.

ETS is also the organization that brings you the SAT, the Test of English as a Foreign Language (TOEFL), the National Teacher Examination (NTE), and licensing and certification exams in dozens of fields, including hair styling, plumbing, and golf.



**What to Take to
the Test Center:**

1. Your registration ticket
2. A photo ID and one other form of ID
3. A snack

TEST DAY

The GRE is administered at Prometric testing centers. This company specializes in administering tests on computer. They administer citizenship exams, professional health certifications, dental exams, accounting exams, and hundreds of other exams on computer. As professional proctors, they are a particularly humorless lot. When you arrive at the center, they will check your ID, give you a clipboard with a form to fill out, and hand you a locker key. Despite the fact that they already have your information, you will be asked to fill out a long form on paper. This form includes an entire paragraph that you have to copy over—in cursive (they specify this)—that states that you are who you say you are and that you are taking the test for admissions purposes. This process will take you about 10 minutes, and you can

complete it while you wait for them to call you into the testing room. The locker is for all of your personal belongings, including books, bags, phones, bulky sweaters, and even watches. You are not allowed to take anything with you into the testing room.

When they call you into the testing room, they will first take a photo of you and, in some cases, fingerprint you before you go in. They will give you six sheets of scratch paper, stapled together to form a booklet, and two sharpened pencils with erasers. Then they lead you into the room where someone will start your test for you. The room itself will hold three or four rows of standard corporate cubicles, each with a monitor and keyboard. There will be other people in the room taking tests other than the GRE. Because people will be entering and exiting the room at different times, you will be provided with optional headphones.

Test Day Tips

- Dress in layers, so that you'll be comfortable regardless of whether the room is cool or warm.
- Don't bother to take a calculator; you're not allowed to use your own—just the one on the screen.
- Be sure to have breakfast, or lunch, depending on when your test is scheduled (but don't eat anything weird). Take it easy on the liquids and the caffeine.
- Do a few GRE practice problems beforehand to warm up your brain. Don't try to tackle difficult new questions, but go through a few questions that you've done before to help you review the problem-solving strategies for each section of the GRE. This will also help you put on your “game-face” and get you into test mode.

- Make sure to take photo identification to the test center. Acceptable forms of identification include your driver's license, photo-bearing employee ID cards, and valid passports.
- If you registered by mail, you must also take the authorization voucher sent to you by ETS.
- Stretch, drink some water, go to the bathroom, and do whatever you need to do in order to be prepared to sit for this four-hour test.

TEST STRUCTURE

While your test structure may vary, you should expect to see something like this when you sit down to take the exam:

The first section of the test collects all of your biographical information. If you fill this out, you will start getting mail from programs that have bought your name from ETS. In general, this is not a bad thing. If you don't want them to sell your name, or you don't want to spend the time answering their questions, you can click on a box that tells ETS not to share your information.

Once all of that is done, you will begin your first scored section, the essays. Your two essays will be back to back. You have 30 minutes for each essay. Immediately after your second essay, you will get your first

multiple-choice section. It may be math or verbal. You will have a 1-minute break between sections. Here is the structure of the test:

Section	Time	# of Questions
Biographical Information	+/- 10 minutes	–
Issue Essay	30 minutes	1
Argument Essay	30 minutes	1
Section 1	30 or 35 minutes	20
Break	10 minutes	–
Section 2	30 or 35 minutes	20
Section 3	30 or 35 minutes	20
Section 4	30 or 35 minutes	20
Section 5	30 or 35 minutes	20
Possible Research Section	Optional	Depends
Select Schools/Programs	5 minutes	Up to 4
Accept Scores	1 minute	–
Receive Scores	1 minute	–



More Online

For gobs of information about the GRE, check out PrincetonReview.com/gre

Here are some things to keep in mind:

- You will see five multiple-choice sections, but only four will count. The fifth is an “experimental” section. It can come at any time after the essays. At the end of the exam, you will know, based on the number of math or verbal sections, if the experimental section was math or verbal, but you will not know which section will not count toward your score.
- Math sections are 35 minutes. There are 20 math questions in each

section. If your experimental section is math, your test will be five minutes longer than someone whose experimental section is verbal.

- Verbal sections are 30 minutes. There are 20 verbal questions in each section.
- The 10-minute break always comes after the third section. You have a 1-minute break between each of the other sections.
- You may or may not get a research section. If you do, it will come last; it does not count toward your score, and it is optional.
- You must accept your scores and, if you choose, send your scores to selected programs prior to seeing your scores.
- If you choose not to accept your scores, neither you nor any program will ever see them.

- You may choose to send your scores to up to four graduate programs on the day of the test. This service is included in your testing fee.

The Experimental Section

When most companies want to test a new product, they provide free samples, test it on animals, or pay for some user testing. Not ETS. ETS uses you as a guinea pig to test out new questions that they will later inflict on other test takers. You pay them to do their research and development, and you do it when you are at your most stressed. Thanks, ETS!

Research Section

At the end of the test, you may also have an unscored research section. At the beginning of this section, you will be told that it is an

unscored research section, and that it will be used only to help develop and test questions for the GRE. If you want to skip it, you have the option of skipping it. You may be offered some sort of prize to induce you to take it, but by that point in the test you will probably be exhausted. If you're offered a research section, just go ahead and decline, get your scores, and go home.

The 10 Minute Break

You are given 1 minute between sections except after section three, when you get a 10-minute break. Go to the bathroom, splash water on your face, wave your arms around. You want to re-oxygenate your brain. The goal, as much as it is possible, is to hit your brain's reset button. When you sit back down for section four, you want it to be as if you are just sitting down at that computer for the first time that day. Your GRE test day is

going to be a long and intense day, so be sure to take full advantage of break time.



Practice Like You Play

When you are tackling practice tests during your test preparation, be sure to mimic the real GRE and give yourself these timed breaks just like the real thing.

Accepting Your Scores

Before you see your scores, you will be given the opportunity to cancel your scores. There are very few reasons to do so. First, if you cancel your scores, you will never see your scores and you will have to go through the

whole experience again, including paying an additional \$185 to take the test again. Second, GRE scores are curved. Most people believe that they are doing worse while taking the test than they actually are. Third, you can make use of the GRE *ScoreSelect*SM service.

ScoreSelect

*ScoreSelect*SM allows you to select which scores get sent to which schools. Options for sending scores depend on whether you are sending scores on the day of your test or after your test day. On test day, you have the following options for sending scores:

- **Most recent.** This option sends the results of the test you just took.
- **All.** This option sends all your scores from the last five years.

If you send your scores to schools after test day, you have even more options. After test day, your options are:

- **Most recent.** This option sends the scores from the test you took most recently.
- **All.** As above, this option sends all your GRE scores from the last five years.
- **Any.** Send just the scores you want to send. You can send one score or multiple scores. For example, if you have taken the GRE three times and your second score is your best, you can send just that score.

When you use *ScoreSelect*SM after your test day, the score report that is sent to schools shows only the scores that you choose to send. The report does not indicate how many times you have taken the GRE nor does it

indicate which that you have sent, for example, the second of three scores on record.

*ScoreSelect*SM is another reason to think twice before cancelling your scores. Provided that you send your scores after your test date, your schools will never know that you didn't do as well as you would have liked or even that you took the test more than once if you don't want them to know.

Sending Additional Score Reports

On the day of your test, you can send your scores to up to four schools using the *ScoreSelect*SM test day options. These score reports are included as part of the \$185 fee that you pay to take the GRE. If you wish to send reports to additional schools, you'll need to request that these additional reports be sent after your test day. Each additional

report costs \$25. The fastest way to send additional score reports is to order them online using your My *GRE*[®] account that you create when you register to take the test.

WHAT DOES A GRE SCORE LOOK LIKE?

Every GRE score has two components: a scaled score and a percentile rank. GRE scores fall on a 130–170 point scale. However, your percentile rank is more important than your scaled score. Your percentile rank indicates how your GRE scores compare to those of other test takers. For example, a scaled score of 150 on the GRE translates to roughly the 43rd percentile, meaning that you scored better than 43 out of every 100 test takers—and worse than the other 57 percent of test takers. A score of 152 is about average, while scores of 163 and above are very competitive. Get the latest reported scores and percentiles at PrincetonReview.com and at www.gre.org, the official ETS website for the GRE.



Plenty o' Practice Tests

Head over to your Premium Portal to gain access to online practice tests that include detailed score reports. These score reports can help guide and focus your test preparation time.

The essays are scored a little differently than are the Verbal and Quantitative sections. All essays receive a scaled score of 0–6, in half-point increments. The corresponding percentiles are as follows:

Score	Analytical Writing Percentile
6.0	99

5.5	97
5.0	93
4.5	78
4.0	54
3.5	35
3.0	14
2.5	6
2.0	2
1.5	1
1.0	<1

In other words, a score of 5 on the essay portion of the GRE means you performed better than 93 percent of test takers.

How Much Does the GRE Matter?

Some programs consider the GRE very important, while others view it as more of a formality. Because the GRE is used for such a wide range of graduate studies, the relative weight it is given will vary from field to field and from school to school. A master's program in English literature will not evaluate the GRE the same way as a PhD program in physics, but it's hard to predict what the exact differences will be. A physics department may care more about the Math score than the Verbal score, but given that nearly all of its applicants will probably have high Math scores, a strong Verbal score might make you stand out and help you gain admission.



Grad School Info

Our Princeton Review homepage has tons of informational articles about graduate school. Head over to PrincetonReview.com/gre and check them out!

Do Your Research

GRE scores are used in a number of different ways. The first step in figuring out how to prepare for the GRE is figuring out how your scores will be used. The only way to do that is to contact the programs to which you plan to apply. Larger programs may have many of these questions already spelled out on their websites. Smaller programs, on the other

hand, may not want to be pinned down to specific answers, and the answers may change from year to year. If you are applying to a smaller program, you will have to dig a bit deeper to get answers to some of these questions. Here are some things you should be asking:

Step 1

1. **What scores do I need to be accepted?** The answer to this question is always “It depends.” The GRE is not the only part of the application, and the quality of the applicant pool varies from year to year. Nevertheless, you need to have a target score so you can figure out how much work you need to put in between now and test day. If the school doesn’t have or

won't quote you a cutoff score, see if you can at least find out the average scores for last year's incoming class.

Step 2

2. **Will you look at all parts of my score?** Some programs may care about your math score, but not your verbal score, and vice versa. Many programs don't use the essay scores at all. If a program doesn't care about your math or your essay score, then you know exactly where to put your prep time.

Step 3

3. **Are scores used for anything else?** If your scores are to be used for placement or for scholarship, it would be good to know that now, while you still have time to prepare.

Step
4

4. **How important are my scores?** In many ways, the importance of scores is a function of how competitive the program is. The scores may not matter much, but if it is a competitive program, every number will count.

Step
5

5. **What do you do with multiple scores?** Depending upon your first scores, you may have to take the test a second time. It would be good to know, however, the importance of that first score. If a school is going to take the highest score, then you can relax a bit on test one, knowing that you can take it again if you need to.

If you plan your testing schedule well, you can send only your highest scores to the school using *ScoreSelect*SM. Remember, however, that you must send your scores after your test day to use the *select any* option for *ScoreSelect*SM.

In any case, remember that the GRE is only one part of an application to grad school. Admissions officers also consider many other factors, including

-
- 8/15/17
- Undergraduate transcripts (that is, your GPA, relevant courses, and the quality of the school you attended)
 - Work experience
 - Any research or work you've done in that academic field
 - Subject GREs (for certain programs)
 - Essays (Personal Statements or other essays)
 - Recommendations
 - Interviews



Premium Portal

Head over to your Premium Portal for tons of pre-graduate school information and guidance

The GRE can be a significant part of your graduate school application (which is why you bought this book), but it certainly isn't the only part.

SCHEDULING A TEST

You can schedule a test session for the GRE by calling 800-GRE-CALL or by registering online at www.gre.org. Registering online is the easiest way to register. As part of the registration process, you'll create a My GRE[®] account. The account will also allow you to see your scores online and make use of the GRE Diagnostic Service, which will give you some insight into your performance. You can also register through a local testing center (the list of centers is available online). After you get the list of local testing centers from ETS, you can call the one nearest you and set up an appointment. You can also call ETS at 609-771-7670 or e-mail them directly at their website to ask any general questions you have about the GRE.

Computer Testing Facts

- You can take the GRE almost any day—morning or afternoon, weekday or weekend. Appointments are scheduled on a first-come, first-served basis. You may take the test only once every 21 days. In addition, you cannot take the test more than 5 times in a continuous rolling 12-month period. Make sure to take your test early enough to book a second test date, if needed, before your applications are due.
- There's no real deadline for registering for the test (technically, you can register the day before). But there's a limited number of seats available on any given day and centers do fill up, sometimes weeks in advance. It's a good idea to register in advance, to

give yourself at least a couple of weeks of lead time.

- The GRE is technically simple. Selecting an answer and moving to the next question involves three easy steps. All you need to do is point the mouse arrow at the answer and click, then click the “Next” button, and then click the “Answer Confirm” button to confirm your choice.
- Because the test is administered on a computer, it is impossible to write directly on the problems themselves (to underline text, cross out answer choices, and so on). Thus, all of your work must be done on scratch paper. Although the amount of scratch paper you may use is unlimited, requesting additional paper takes time. You should be efficient and organized in how you use it; learning to use your scratch paper effectively is one

of the keys to scoring well on the GRE.

- When you've finished taking the test, you will be given the option to accept or cancel your scores. Of course, you have to make this decision before you learn what the scores are. If you choose to cancel your scores, they cannot be reinstated, and you will never learn what they were. No refunds are given for canceled scores, and your GRE report will reflect that you took the test on that day and canceled (though this shouldn't be held against you). If you choose to accept your scores, they cannot be canceled afterward. We suggest that unless you are absolutely certain you did poorly, you accept your score.
- You will receive your Verbal and Math scores the instant you finish the exam (provided that you choose not

to cancel your score), but your Analytical Writing scores and “official” percentile scores for all three sections won’t get to you until a few weeks later. If you registered for your test online, you’ll be able to access your official scores through your My *GRE*® account.

- ETS offers the GRE Diagnostic Service (grediagnostic.ets.org) as a free option for test takers to have a limited review of their tests. This service allows you to see the number of questions you missed and where they fell on the test, but you cannot review the actual questions. The diagnostic service also claims to let you know the difficulty of the questions you missed, but the scale used—a simple scale of 1 to 5—is not particularly useful.

Accommodated Testing

If you require accommodated testing, please see the Appendix at the end of this book. It contains information on the forms you'll need to fill out and procedures you'll need to follow to apply for accommodated testing. Be sure to start that application process well in advance of when you want to take your test, as it can take many weeks to complete.

HOW TO USE THIS BOOK

This book is chock full of our tried-and-true GRE test-taking techniques, some of which, at first, might seem to go against your gut instincts. In order to take full advantage of our methods, however, you'll have to trust them and use them consistently and faithfully.



Make sure to use the techniques on all of the practice problems you do and to thoroughly review the explanations for all of the questions—even the ones you get right. That way, the techniques will become second nature to you, and you'll have no problem using them on test day.

Practice for Technique, Not for Result

There is a finite amount of GRE material available in the world. Once you have used it all up, that's it. You don't get any more. Many people will work through the books, doing problems, looking for answers. When they get a problem right, they are happy. When they get a problem wrong, they are frustrated, and then they go on to the next problem. The problem with this approach is that you can churn through lots and lots of questions without ever actually getting better at taking the GRE. The techniques you use and the way you solve a problem are what matters. The results just tell you how you did. When you are practicing, always focus on your approach. When you get good at the techniques, your score will take care of itself. If you focus on just the results, you do nothing more than reinforce the way you are taking the test right now.

Additional Resources

In addition to the material in the book, we offer a number of other resources to aid you during your GRE preparation.



With your purchase of this book, you gain access to many helpful tools in your Premium Portal, which is the companion website that goes with this book. There you will find 4 full-length practice GRE exams, assorted videos in which Princeton Review teachers discuss graduate school admissions, GRE strategy, and much more, plus tons of useful articles, essays, and information. Go to PrincetonReview.com to register. PrincetonReview.com/gre also contains a ton of useful information on graduate programs,

financial aid, and everything else related to graduate school.

Real GREs

The practice problems in this book are designed to simulate the questions that appear on the real GRE. Part of your preparation, however, should involve working with real GRE problems. Working with real questions from past GRE exams is the best way to practice our techniques and prepare for the test. However, the only source of real GREs is the publisher of the test, ETS, which so far has refused to let anyone (including us) license actual questions from old tests.

Therefore, we strongly recommend that you obtain *POWERPREP*[®] *II* software for the computer-based GRE revised General Test. You can download the *POWERPREP II* software directly from ETS's website. It contains

two full-length adaptive revised General Test. In addition, you can download the PDF *Practice Book for the Paper-based GRE® Revised General Test*. While the format of the paper-based test is different from the computer-based test, the practice questions contained in the PDF are relevant and useful.

ETS also publishes *The Official Guide to the GRE® revised General Test*. This book (approximately \$35) can be found online or at most major book stores. Some of the practice questions in this book, however, are identical to the questions in the PDF, which is a free download.

Whatever you're using, always practice with scratch paper. As you prepare for the GRE, work through every question you do as if the question is being presented on a computer screen. This means not writing anything on the problems themselves. No crossing off

answers, no circling, no underlining. Copy everything to scratch paper and do your work there. You shouldn't give yourself a crutch in your preparation that you won't have on the actual test.

MAKING A SCHEDULE

The GRE, like other standardized tests, is not a test for which you can cram. While you may have fond memories from your college days of spending the night before the midterm with a pot of coffee and a 500-page economics textbook, that strategy won't be as effective on the GRE. Why? Because, by and large, the GRE is a test of patterns, not of facts. This book does its best to reveal those patterns to you, but without sufficient time to practice and absorb the information in this book, your GRE score is not likely to improve. Thus, you should allow an adequate amount of time to fully prepare for the GRE.



Premium Portal

You're in luck! Since you purchased the Premium Edition, we have created a few schedules for you already! Go online to find our 4, 8, and 12 week GRE preparation schedules and select the one that is right for you.

You should allow yourself somewhere between 4 and 12 weeks to prepare for the GRE. Obviously we can't know exactly where you are in terms of your starting score, your target score, and the amount of time you can devote to studying, but in our experience, 4 weeks is about the minimum amount of time you'd want to spend, while 12 weeks is about the maximum. There are a number of reasons for these suggested preparation times. Attempting to prepare in fewer than 4 weeks typically does not allow sufficient time to master the techniques presented in this

book. As you'll see, some of our approaches are counterintuitive and take some getting used to. Without adequate practice time, you may not have full confidence in the techniques. Additionally, vocabulary is part of the Verbal section of the GRE and it's difficult to substantially increase your vocabulary in a short period of time. Finally, as mentioned before, the GRE contains a number of patterns, and the more time you spend studying the test, the better you will be at recognizing these patterns.

On the other hand, spending an inordinate amount of time preparing for the GRE can have its downside as well. The first concern is a purely practical one: There is a finite amount of GRE practice material available. Budgeting six months of preparation time is unproductive because you'll run out of materials in less than half that time. Finally, spreading the material out over a long period

of time may result in your forgetting some of the lessons from the beginning of your studies. It's better to work assiduously and consistently over a shorter time period than to dilute your efforts over a long time frame.

STAY UP TO DATE

We at The Princeton Review will continue to learn all about the new GRE as it evolves. As you prepare for your GRE, make sure you periodically check both our website at PrincetonReview.com and the GRE website at www.gre.org for the latest updates and information about the test.



WANT EVEN MORE PREP?

The Princeton Review offers an assortment of test preparation options: Classroom and online courses plus private and small group tutoring. We also have a bunch of other helpful GRE preparation books, including *Math Workout for the GRE*, *Verbal Workout for the GRE*, *1,007 GRE Practice Questions*, and *Crash Course for the GRE*. When it comes to test preparation for the GRE, we've got you covered.

Now that we have that introduction out of the way, let's dive in and talk strategy.

Summary

- The GRE is a 3-hour, 40-minute exam used by graduate schools to rank applicants.
- The GRE tests your mathematical, verbal, and writing abilities.
- The importance of your GRE score varies from program to program. Schools also consider your undergraduate record, your personal essays, and your relevant experience.
- GRE tests can be scheduled online at www.gre.org.

Chapter 2

General Strategy

This chapter contains some basic advice to get you into The Princeton Review mindset. You'll learn some core test-taking strategies to help you maximize your score. In addition, you'll see some of the different question formats you will probably encounter on test day.

CRACKING THE SYSTEM

Although ETS claims that the GRE measures “critical thinking, analytical writing, verbal reasoning, and quantitative reasoning skills that have been acquired over a long period of time,” that isn’t quite true. Again, what the GRE really measures is how well you take the GRE. The first step to bettering your GRE score is realizing that you can improve your score, in many cases substantially, by familiarizing yourself with the test and by practicing the techniques in this book.



I Thought the GRE Was Coach-Proof

ETS would have you believe that its tests are coach-proof, but that is simply untrue. In many ways, taking a standardized test is a skill and, as with any skill, you can become more proficient at it by both practicing and following the advice of a good teacher. Think of your GRE preparation as if you were practicing for a piano recital or a track meet; you wouldn't show up at the concert hall or track field without having put in hours of practice beforehand (at least we hope you wouldn't!). If you want to get a good score on the GRE, you'll have to put in the necessary preparation time.

Why Should I Listen to The Princeton Review?

Quite simply, because we monitor the GRE. Our teaching methods were developed through exhaustive analysis of all of the available GREs and careful research into the methods by which standardized tests are constructed. Our focus is on the basic concepts that will enable you to attack any problem, strip it down to its essential components, and solve it in as little time as possible.

Think Like the Test Writers

You might be surprised to learn that the GRE isn't written by distinguished professors, renowned scholars, or graduate school admissions officers. For the most part, it's written by ordinary ETS employees, sometimes with freelance help from local graduate

students. You have no reason to be intimidated by these people.

As you become more familiar with the test, you will also develop a sense of “the ETS mentality.” This is a predictable kind of thinking that influences nearly every part of nearly every ETS exam. By learning to recognize the ETS mentality, you’ll earn points even when you aren’t sure why an answer is correct. You’ll inevitably do better on the test by learning to think like the people who wrote it.

The Only “Correct” Answer Is the One That Earns You Points

The instructions on the GRE tell you to select the “best” answer to each question. ETS calls them “best” answers, or “credited” responses, instead of “correct” answers to

protect itself from the complaints of test takers who might be tempted to quarrel with ETS's judgment. Remember that you have to choose from the choices ETS gives you, and sometimes, especially on the Verbal section, you might not love any of them. Your job is to find the one answer for which ETS gives credit.

Cracking the System

“Cracking the system” is our phrase for getting inside the minds of the people who write these tests. This emphasis on earning points rather than finding the “correct” answer may strike you as somewhat cynical, but it is crucial to doing well on the GRE. After all, the GRE leaves you no room to make explanations or justifications for your responses.

This is NOT a test of
intelligence!

You'll do better on the GRE by putting aside your feelings about real education and surrendering yourself to the strange logic of the standardized test.

TWO SECTION ADAPTIVE

The GRE is adaptive by section. That is, you will see two Math sections and two Verbal sections, but the difficulty level of the second section of either subject is determined by your performance on the first section. The more questions you answer correctly on the first section, the harder your second section will be. While your accuracy on a harder section two is likely to be lower than it would be on an easier section two, you are better off with the harder section. To get a high score on the GRE, you must get to the hardest questions and answer them correctly. The selection of the second section is purely a function of the number of questions you answer correctly. The difficulty of an individual question plays no part. When the GRE converts your raw score (the actual number of right and wrong questions) to your scaled

score (130–170), however, the level of difficulty will play a role.

GENERAL STRATEGIES

Step 1

1. Take the Easy Test First

Within a section, each question counts equally toward your score. There will inevitably be questions you are great at and questions you don't like. The beauty of the GRE is that there is no need to bow to Phoenician numerical hegemony; you can answer questions in any order you like. The question you can nail in 25 seconds is worth just as much as the question that will torture you for minutes on end. To maximize your score, leave the questions you don't like for last. If you are going to run out of time

anywhere—and unless you are shooting for a 160 or higher, you should be running out of time—make sure that the questions that get chopped off are the ones you didn't want to answer anyway.

This strategy is called Take the Easy Test First. Skip early and skip often. Doing so will result in two passes through an individual section. On the first pass, cherry pick. Answer the questions you like. Get all of those easy points in the bank before time starts running short. You know that the hard questions—or the ones that you don't like—are going to take more time. Also, although you should never rush, everyone starts to feel the pressure of the clock as time starts running low. This is often when mistakes happen. Leave those difficult, time-consuming questions for the end of the test. If you run out of time or make some mistakes at that point, it

won't matter because these are low percentage questions for you anyway.

Step 2

2. Mark and Return

On your first pass through the questions, if you see a question you don't like, a question that looks hard, or a question that looks time consuming, you're going to walk on by and leave it for the end. Sometimes, however, a question that looks easy turns out to be more troublesome than you thought. The question may be trickier than it first appeared, or you may have simply misread it, and it seems hard only because you're working with the wrong information. From start to finish, the GRE is nearly a four-hour test. Over four hours your brain is going to get tired. When

that happens, misreading a question is virtually inevitable. Once you read a problem wrong, however, it is almost impossible to un-read the problem and see it right. As long as you are still in the problem, you could read it ten times in a row and you will read it the same wrong way each time.

Whether a question is harder than it first appeared, or made harder by the fact that you missed a key phrase or piece of information, the approach you've taken is not working. This is where the Mark button comes in.

Reset your brain by walking away from the problem, but Mark the question before you do. Do two or three other questions, and then return to the marked problem. When you walk away, your brain doesn't just forget the problem, it keeps on processing in the back ground. The distraction of the other questions helps your brain to consider the

question from some other angles. When you return to the problem, you may find that the part that gave you so much trouble the first time is now magically clear. If the problem continues to give you trouble, walk away again.

Staying with a problem when you're stuck burns time but yields no points. You might spend 2, 3, 5, or even 6 minutes on a problem but still be no closer to the answer. Spending 5 minutes to get one point will not get you enough points on a 30- or 35-minute section. In the 5 minutes you spend on a problem that you've misread, you could nail three or four easier questions. When you return to the question that gave you trouble, there is a good chance that you will spot your error, and the path to the correct answer will become clear. If it doesn't become clear, walk away again. Any time you encounter resistance on the test, do not keep pushing; bend

like a reed and walk away. Use the Mark button to facilitate this key skill. Skip early and often so that you always have questions to distract your brain when you get stuck.

Step 3

3. Use the Review Screen to Navigate

Within a single section you can mark an answered or unanswered question and return to it later. In fact you can skip any question you like and return to any question at any time you like. Navigating around a section is easy with the new Review Screen, which looks like this:

Question Number	Status	Marked
1	Not Answered	
2	Not Answered	✓
3	Not Answered	
4	Not Answered	
5	Not Answered	
6	Not Answered	
7	Answered	
8	Answered	
9	Answered	✓
10	Answered	✓
11	Answered	
12	Not Answered	

Simply click on a question and hit the button marked “Go To Question,” and you will return directly to that question. This opens up a whole new realm of strategic opportunities for the savvy test taker.

Step 4

4. Slow Down/Work for Accuracy

Speed kills on the GRE. The clock has a way of infecting your brain. Just knowing that there is a ticking clock provokes mistakes. The trick is to take each section as if there is no clock. As long as you are skipping the hard ones and using the Mark button and coming back every time you run into trouble, you should get very few questions in a section wrong. Wrong answers drag your score down and often take up even more time than the right ones!

Remember that it is not the number of questions that you answer that gives you your

score; it is the number of questions you answer correctly. Accuracy is everything. Ignore the clock. Slow down and work for accuracy only. If you run into a brick wall, don't keep spending time; do an easier question and come back. The minute you try to go faster, however, your accuracy will go down and take your score along with it.

Accuracy is all that matters. Walk away often.

There is only one exception to this, and that is the last two minutes of a section. A skipped question and a wrong answer count the same. In other words, there is no penalty for “guessing” on a question you don't know. When two minutes remain on your clock, stop what you're doing and bubble in answers to any remaining unanswered questions. Use the Review button to quickly see which questions you haven't answered. A few

lucky guesses will pay off. If you don't get any of them right, no harm done.

To avoid careless mistakes and to make the best use of your time, we suggest the following:

1. **Be Aware of Your Personal Order of Difficulty.** Spend your time on the questions that are easiest for you. Work through them methodically and accurately and collect points.
2. **Use the Two-Pass System.** The Two-Pass system involves taking each section in two parts, or passes. During the first pass, focus on all the questions that you're comfortable with. On the second pass, return to the tougher questions and do the best you can on them in the remaining time.

Step 5

5. Use Process of Elimination

Because there are many more wrong answers on the GRE than there are credited answers, on some of the more difficult questions (those you do on your second pass) you'll actually be better served not by trying to find the *best* answer, but instead by finding the wrong answers and using POE, Process of Elimination.

ETS Doesn't Care How You Get the Best Answer

Remember when you were in high school, and even if you got a question wrong on a

test, your teacher gave you partial credit? For example, maybe you used the right formula on a math question, but miscalculated and got the wrong result, but your teacher gave you some credit because you understood the concept?

Well, those days are over. There is no partial credit on the GRE. On the other hand, ETS doesn't know or care how you get the right answer. A lucky guess is worth just as many points as a question that you solve completely and correctly.

There is one thing for which we must thank ETS. They have actually given us the answers! For most problems, there are five answer choices, and one of them is correct. It is important to remember that the answer choices are part of the problem. Many of them will be clearly wrong and can, therefore, be eliminated. In fact, sometimes it is

easier to identify the wrong answers and eliminate them than it is to find the right ones. This approach is called Process of Elimination, or POE.

POE will be crucial on the verbal side of the test. Vocabulary-based questions will include plenty of words you don't know. For such questions, you may not be able to identify the correct answer, but you will certainly be able to identify some wrong ones. Get rid of the wrong ones so that when you guess, you have a fifty-fifty shot and not a 20 percent chance. The same holds true for the reading comp questions, which will include plenty of answer choices that are clearly wrong.

On the math side of the test, ETS loves to sucker you into doing more math than is really necessary. You can often eliminate answer choices that are clearly too large or too small. Sometimes it is even more efficient to

eliminate wrong answers than it is to do the math required to come up with the right one.

The Importance of Distractors

By using POE, you will be able to improve your score on the GRE by looking for wrong answers instead of right ones, on questions you find difficult. Why? Because, once you've eliminated the wrong ones, picking the right one can be a piece of cake.

Wrong answers on standardized multiple-choice tests are known in the testing industry as “distractors,” or “trap answers.” They are called distractors because their purpose is to distract test takers away from correct choices. Trap answers are specifically designed to appeal to test takers. Oftentimes, they're the answers that seem to scream out “pick me!” as you work through a question.

However, these attractive answers are often incorrect.

Remembering this simple fact can be an enormous help to you as you sit down to take the test. By learning to recognize distractors, you will greatly improve your score.

Improve Your Odds Indirectly

Every time you're able to eliminate an incorrect choice on a GRE question, you improve your odds of finding the best answer; the more incorrect choices you eliminate, the better your odds.

For this reason, some of our test-taking strategies are aimed at helping you arrive at ETS's answer indirectly. Doing this will make you much more successful at avoiding the traps laid in your path by the test writers.

This is because most of the traps are designed to catch unwary test takers who try to approach the problems directly.

POE and Guessing

If you guessed blindly on a five-choice GRE problem, you would have a one-in-five chance of picking ETS's answer. Eliminate one incorrect choice, and your chances improve to one in four. Eliminate three, and you have a fifty-fifty chance of earning points by guessing. Get the picture?

Guess, but guess intelligently.

Step
6

6. Use Your Scratch Paper

ETS doesn't give you many useful tools on this test, so you have to make good use of the ones they do give you. You will get six sheets of scratch paper stapled into a booklet. You can get more by raising your hand during a section, but that takes time, so you will need an efficient system for using scratch paper.

Mistakes happen in your head, but good technique happens on scratch paper. When you do work in your head, you are really doing two things at once. The first is figuring out the answer at hand, and the second is keeping track of where you've been. Mistakes happen when you try to do two things in your head at once. It's better to park your thinking on your scratch paper. Get it out of your head and onto the page. Good things happen when you do.



Remember

By crossing out a clearly incorrect choice, you permanently eliminate it from consideration.

On the math side, scratch paper is crucial. Not only is it important for performing complicated calculations, but when used properly, it can actually help to direct your thinking as you work through multi-step problems. In the math sections of this book, we will give you graphic set-ups for each math concept that you will encounter. Use them consistently, and they will become good habits that will pay big dividends in accuracy, even over a four-hour exam.

On the verbal side, scratch paper is every bit as essential. It will help you to track your progress, to focus on only one answer choice at a time, and to work through a series of answer choices efficiently. In the verbal section of this book, we will give you a process for using scratch paper efficiently and effectively.

Step 7

7. Double-Check

Get into the habit of double-checking all of your answers before you click on your answer choice—or answer choices. Make sure that you reread the directions and have done everything they asked you to—don't get the answer wrong just because you chose only

one answer for a question that required you to choose two or more.

The only way to reliably avoid careless errors is to adopt habits that make them less likely to occur. Always check to see that you've transcribed information correctly to your scratch paper. Always read the problem at least twice and note any important parts that you might forget later. Always check your calculations. And always read the question one last time before selecting your answer.

By training yourself to avoid careless errors, you will increase your score.

Step 8

8. Let It Go

Every time you begin a new section, focus on that section and put the last section you completed behind you. Don't think about that pesky synonym from an earlier section while a geometry question is on your screen. You can't go back, and besides, your impression of how you did on a section is probably much worse than reality.

Step 9

9. Don't Make Any Last-Minute Lifestyle Changes

The week before the test is not the time for any major life changes. This is NOT the week to quit smoking, start smoking, quit drinking

coffee, start drinking coffee, start a relationship, end a relationship, or quit a job. Business as usual, okay?

YOUR STARTING POINT

Before you dive in, you might wish to take one of the practice tests in this book or online to get a sense of where you are starting out from. It can be a good exercise to tackle a practice test before you know any strategies or have reviewed any content—while you have relatively fresh eyes to the test-taking experience. This will be a good initial impression and these first scores will show you what content areas need your focus. Of course, you'll review all necessary content for the GRE (won't you?), but this first test can serve as a helpful guide. Then as you learn strategies and review math and verbal content, you'll have a genuine sense of accomplishment.

Now let's get cracking!

Summary

- You can increase your score on the GRE through practice and successful application of test-taking strategies.
- The GRE uses a variety of question formats throughout the test.
- Not all questions on the GRE are of equal difficulty. Your Personal Order of Difficulty should tell you which questions to spend time on and which to skip.
- Accuracy is better than speed. Slow down and focus on accumulating as many points as possible. Forcing yourself to work faster results in careless errors and lower scores.

- Process of Elimination is an extremely useful tool on the test. Use it to eliminate wrong answers and increase your odds of guessing correctly.

Part II

How to Crack the Verbal Section

[3 The Geography of the Verbal Section](#)

[4 Text Completions](#)

[5 Sentence Equivalence](#)

[6 Reading Comprehension](#)

[7 Critical Reasoning](#)

[8 Vocabulary for the GRE](#)

Chapter 3

The Geography of the Verbal Section

The Verbal section of the GRE is designed to test your verbal reasoning abilities. This chapter will explain what types of questions ETS uses to accomplish that. You'll also see how the concepts of Personal Order of Difficulty and Process of Elimination apply to the Verbal section. Finally, you'll learn what role vocabulary plays in achieving a good score on the Verbal section.

WHAT'S ON THE VERBAL SECTION

A few years ago, ETS redesigned the GRE and claimed that the new Verbal section would accomplish the following:

- Place a greater emphasis on analytical skills and on understanding vocabulary in context rather than in isolation.
- Use more text-based materials.
- Contain a broader range of reading selections.
- Test skills that are more closely aligned with those used in graduate school.
- Expand the range of computer-enabled tasks.

What does this mean for you?

- There won't be questions that involve analogies or antonyms on this test, as there had been on the old version of the GRE.
- You'll see some wacky-looking question formats that you've probably never seen before.
- Though they say the new version of the test de-emphasizes vocabulary, there's no getting around the fact that the more vocabulary you know when you sit down to take the test, the better off you'll be. So vocabulary remains as important as it ever was. If you're especially eager to build your vocabulary, check out [Chapter 8: Vocabulary for the GRE](#).

There are three types of questions on the Verbal section of the test:

- Text Completions
- Sentence Equivalence

- Reading Comprehension

Text Completions

Text Completion questions consist of a short section of text, between one and five sentences, with one to three blanks. A one-blank Text Completion will have five answer choices while a two-blank or three-blank Text Completion will have three choices per blank. Your job is to find the best word for each blank.



They look like this:

Fables often endure due to their (i)
_____, often telling one
simple narrative, based around one

character. This is both by design, because direct statements are more easily remembered than florid ones, and by accident: As fables are passed from teller to teller, (ii)

_____ details fall away, leaving only the essential story.

Blank (i)

bombast
objectivity
simplicity

Blank (ii)

superfluous
requisite
apocryphal

Sentence Equivalence

Sentence Equivalence questions are similar to Text Completion questions. You will be given a single sentence with one blank and six answer choices. Your job is to select two words from the answer choices that could fit in the blank. Here's what they look like:

He was a man of few words,
_____ around all but his closest
friends.

- laconic
- garrulous
- ascetic
- taciturn
- tempestuous
- ambiguous

Reading Comprehension

Reading Comprehension questions make up the lion's share of the verbal portion of the test. In fact, Reading Comprehension questions make up about half of each verbal section. You will be given a passage that may vary in length from one to five paragraphs with one to five questions per passage.

Reading Comprehension questions might ask you for the main idea of the passage; they might ask about specific pieces of information in the passage; they might ask you about the structure or tone of a passage; they might ask you about vocabulary in the passage, the point of view of the author, or about the argument being made in the passage. The good news about Reading Comprehension questions is that they rarely depend upon vocabulary, and the answers are always in the passage.

Within Reading Comprehension, there are three question formats:

Multiple Choice

Question 20 is based on this passage.

After examining the bodies of a dozen beached whales and finding evidence of bleeding around the animals' eyes and brains as well as lesions on their kidneys and livers, environmental groups fear that the Navy's use of sonar is causing serious harm to marine animals. A leading marine biologist reports that sonar induces whales to panic and surface too quickly, which causes nitrogen bubbles to form in their blood.

The argument above relies on which of the following assumptions?

- Marine biologists have documented that other marine animals, including dolphins and sea turtles, have exhibited kidney and liver lesions.
- No studies have been conducted on the possible detrimental effects of sonar on marine animals.
- Whales in captivity panic only when exposed to man-made, rather than natural, sound waves.
- The presence of nitrogen bubbles in the blood has been demonstrated to cause damage to various internal organs.
- It is unlikely that the symptoms found in the beached whales could be caused by any known disease.

Select All That Apply

Questions 10 and 11 are based on this passage.

What was it about Oscar Wilde's only novel, *The Picture of Dorian Gray*, that caused it to create such an uproar when it was published in 1891? While critics attacked the quality of Wilde's formal elements, their denunciation merely masked the true concerns of many nineteenth-century critics. What these critics were actually railing against was the thematic content of Wilde's work, specifically his illustration of a lifestyle devoted to useless beauty. For many a nineteenth-century moralist, *The Picture of Dorian Gray* was nothing more than a primer for spiritual depravity. Wilde's ultimate sin was his leniency toward his protagonist, an unabashed hedonist. To the critics, allowing an evil character to escape his just desserts was an unforgivable sin. In their minds, Wilde's work was corrupting the genteel reading public by failing to show the proper consequences of immoral behavior.

Consider each of the choices separately and select all that apply.

The author of the passage would probably agree with which of the following statements?

- Most critics of Oscar Wilde's novel objected primarily to the lifestyle of its author.
- If *The Picture of Dorian Gray* were written in the twentieth century, the critical reaction would be less severe.
- Some critics of Wilde's *The Picture of Dorian Gray* believed that an author of a book had a moral responsibility to the book's audience.

Select in Passage

Question 16 is based on this passage.

Called by some the “island that time forgot,” Madagascar is home to a vast array of unique, exotic creatures. One such animal is the aye-aye. First described by western science in 1782, it was initially categorized as a member of the order Rodentia. Further research then revealed that it was more closely related to the lemur, a member of the primate order. Since the aye-aye is so different from its fellow primates, however, it was given its own family: *Daubentonidae*. The aye-aye has been listed as an endangered species and, as a result, the government of Madagascar has designated an island off the northeastern coast of Madagascar as a protected reserve for aye-ayes and other wildlife.

Click on the sentence that would most seriously weaken the author's claim that “this practice may result in the loss of a superb example of life's variety.”

HOW IS THE GRE VERBAL SECTION STRUCTURED?

The GRE has two scored multiple-choice verbal sections. Each will be 30 minutes long with 20 questions per section. The way you perform on one verbal section will affect the difficulty of the next verbal section you are given. Verbal sections tend to follow the same order. Roughly your first six questions will be Text Completion, your next five or six will be Reading Comprehension, followed by about four Sentence Equivalence, and then another four or five Reading Comprehension questions. In profile, your two verbal sections will look something like this:

Question	1	2	3	4	5	6	7	8	9	10	11	12	13	14	15	16	17	18	19	20
Section 3	Text Completion						Reading Comprehension					Sentence Equivalence				Reading Comprehension				
Section 5	Text Completion						Reading Comprehension					Sentence Equivalence				Reading Comprehension				



BASIC STRATEGIES FOR THE GRE VERBAL SECTION

Here are some strategies that will help you on the Verbal section. We'll show you how to use them as we go through specific question types in the chapters ahead, but for now read through the strategies and get a sense of what they are before moving on.

Personal Order of Difficulty

One very important thing to keep in mind as you go through the Verbal section is that you can control which questions you do and when you do them. Once again, you're able to skip around the test, so do the questions in any order you like. If you come to a question that stumps you, skip it and move on to the next one. Go back to the hard ones at the end of the section if you have

time—remember that all questions are worth the same number of points, so you won't get any more credit for answering a hard question than answering an easy one—use your time wisely.



Premium Portal

Check out our Premium Portal for helpful opinions and advice for GRE test takers.

We call this method the Two-Pass system. In the Two-Pass system, you do the following:

1. **First Pass:** Go through the test, doing all the questions you feel confident on. Skip any questions that are

confusing or seem to be taking you a while to work out.

2. **Second Pass:** Return to the questions you skipped and give them a shot; you'll feel more relaxed because you'll have completed most of the section and done well on it, and you can settle in and give them your full attention.

Process of Elimination (POE)

One important point to keep in mind here is that on verbal questions, your goal is to find the “best” answer. Note that this doesn't mean the same thing as finding the “right” answer or the “correct” answer. On this section, it's essential that you get into the habit of considering every answer choice, even if you're pretty sure you've already found the answer. After all, there's no way of saying

one answer is the “best” unless you’ve compared it to all the others.

Sometimes it’s far easier to find the wrong answer to a verbal question than the right one; after all, statistically there are far more wrong answers on the test than correct ones. This is where the Process of Elimination comes into play. If you can recognize a bad answer and eliminate it, you will greatly increase your odds of choosing the right answer if you must guess on a question.

Intelligent guessing—guessing after eliminating at least one answer choice—is a good way to get the best GRE verbal score you can get. Consider the following question:

When studying human history, one must be aware that the

_____ between historical periods are arbitrary; certainly none of the people alive at the time were aware of a shift from one era to another.

judgments
ideologies
innovations
demarcations
episodes

Here's How to Crack It

If you encountered this question on the GRE, you might not know what the best answer is (you'll learn how to approach questions like this in [Chapter 4](#)). However, you might see that some of the answers simply don't make sense. Choices (A), (B), and (C) don't seem to fit the sentence at all. By eliminating these wrong answers, you've suddenly given

yourself a great chance of choosing the correct answer just by guessing, since only answer choices (D) and (E) are left. And if you realize that choice (E) doesn't make sense either, then you know the correct answer is (D), even if you're not sure what "demarcations" means. Sometimes it's easier to find the wrong answer than the right answer.



THE IMPORTANCE OF VOCABULARY

Although ETS says that vocabulary is de-emphasized on this test, having a wide vocabulary will still help you on the GRE. Text Completion questions and Sentence Equivalence questions rely heavily on vocabulary, and reading passages can and will contain some tough words in both the passages and in the answer choices.

To that end, working on improving your vocabulary can translate into higher scores on the GRE. We've provided you with the Hit Parade in [Chapter 8](#); it's a list of words commonly used on the GRE, but that's only the beginning. As you read books and newspapers, watch movies or television, or talk to your sesquipedalian friends, keep track of any and all new vocabulary words you read

or hear, write them down, look them up, and remember them. There's a good chance they'll come in handy on test day.

GENERAL STRATEGIES FOR THE GRE VERBAL SECTION

Scratch Paper—Say No to Multitasking

Scratch paper is every bit as important on the verbal side of the test as it is on the math. When you answer a verbal question in your head, you are really doing two things at once. The first is evaluating each answer choice; the second is keeping track of which answer choices are still in and which ones you don't like. This is multitasking, and the problem with multitasking, studies have shown, is that you end up doing both tasks worse! Multitasking leads to inefficient use of time as you end up revisiting answer choices that you've already evaluated, and it leads to

errors as you distract your brain with other tasks while making crucial choices.

Three Kinds of Words

As you encounter difficult words throughout this book, put them in one of these three categories:

- **Words you know**—These are words you can define accurately. If you can give a definition of a word that's pretty close to the dictionary definition, then it is a word you know.
- **Words you sort of know**—These are words you've seen or heard before, or maybe even have used yourself, but can't define accurately. You may

120/1507

have a sense of how these words are used, but beware! Day-to-day usage is often different from the dictionary meaning of words, and the only meanings that count on the GRE are those given in the dictionary. ETS likes using words that have secondary meanings, and some of the words in this category may have secondary definitions that you're not aware of. You have to treat these words very differently from the words you can define easily and for which you know all the meanings. Every time you encounter a word you sort of know in this book, be sure to look it up in the

dictionary and make it a word you know from then on.

- **Words you've never seen**—You can expect to see some words in this book you've never seen before. After you encounter a word like this, look it up! If it's been on the GRE one year, there's a good chance it will show up again.

The better approach is to engage your hand and take a load off your brain by parking your thinking on the page. The answer choices represent ETS's suggested answers. They are carefully designed to mislead the tired test taker. Because of this, you should always have a clear sense of what you're looking for before you get to the answer

choices. When you do get to the answer choices, it's a simple assessment: Does it match your answer or not? This is an easy call to make. If the answer is a vocabulary word, either you know the word and it works, you know the word and it doesn't work, or you don't know the word. If it is a Reading Comprehension question, either the answer matches your answer, it does not match, or you're not sure. As you evaluate each answer choice, mark your assessment on your scratch paper. Verbal scratch paper looks like this:

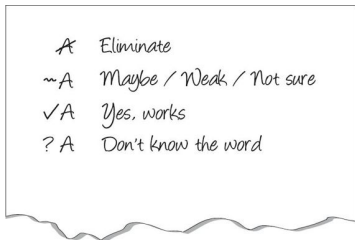

We will discuss different strategies for setting up scratch paper for specific question types later on, but there are four basic symbols you will use for all questions:

- ✘ **Eliminate**—When an answer choice is clearly wrong, get rid of it. Having it there as an option is nothing but a distraction, so make it go away.

- ~ **Maybe**—Don't be afraid of the Maybe. GRE students often get hung up considering a particular answer choice. On the first pass through the answer choices, this is time wasted. It is entirely possible that the other four answer choices are wrong, or that you find one that is clearly better. Before you invest too much time (too much time means more than 5 seconds) on any one answer choice, give it the *Maybe* and move on. You can always come back to it and give it more time *if*

133/1507

you have to, but you never want to give it more time *than* you have to. If you're not sure or you don't love it, just give it the *Maybe* and move on.

✓ **Yes, Works**—When you have one that works, give it the check mark.

? **Question Mark**—If you don't know the meaning of a word, mark it with a question mark. You must be honest with yourself here. You do yourself no favors by acting like you know a word more than you actually do. You cannot eliminate a word just because it looks bad. You don't have to pick it, but if you don't know it, you can't eliminate it.

Stressed About Vocab?

Check out The Princeton Review's flashcards, *Essential GRE Vocabulary*,

You are taking a two-pass approach through the answer choices. On the first pass, it's a simple question of *Maybe* or *Eliminate*? Park your thinking on the page and nine out of ten times your scratch paper will be able to answer the question for you. If you have two question marks and a check, you're done. The check is your answer. If you have two maybes and a check, you're done; the check is your answer. If you have four eliminates and a question mark, the question mark is your answer.

Using scratch paper on the Verbal section is a habit. It's something you do every time. Over time, it should just become automatic. When you're working on a verbal question, your hand should be moving. This will save you time and mental effort. Remember that

it is a four-hour exam, and over four hours, your brain will get tired. Saving mental effort makes a difference and helps to avoid mistakes. The job of the techniques is to help you with the hard problems, but it is also to ensure that the questions you should be getting right, you are getting right. Both jobs are equally important. Start using scratch paper now and force yourself to keep doing it until it becomes habit.

Take the Easy Test First

The GRE is all about accuracy. It's not the number of questions you answer that determines your score; it's the number of questions you answer correctly. It is more important to get questions correct than to get to answer all questions. Since all questions within a given section count equally toward your score, you might as well do the easy ones first. If you love Text Completion, but

hate Reading Comprehension, then do the Text Completion first.

Work slowly. Work for accuracy. Skip often. When a question pops up that you don't like, click to the next one. You can always come back and answer it later, time provided, but take the easy test first. Invest your time in those questions you like. That way, when you run short on time, you have nothing left but the questions you don't like doing anyway. Another way to think about it is to play to your strengths. As you work through this book and learn new techniques, the types of questions you decide to skip might change. Just because they give you questions in a specific order doesn't mean you have to answer them in that order.

You are in control of question order.
Take the easy test first!

Bend—Don't Push

Over a period of four hours, your brain will get tired. When that happens, you will misread a question, a sentence, or an answer choice. It is inevitable. When you go back and look at these questions later, you will smack your forehead and think, “That was so stupid! Why did I do that? That’s not what it says at all. I thought ...” Everyone has these moments. It happens because most of us no longer read things word for word. We read in chunks. We don’t read words anymore; we recognize words. Sometimes, especially when our brains get tired, we get these chunks wrong or we recognize a different word. The problem is that once you have

seen a question or a word wrong, it is all but impossible to see it correctly.

The solution is to walk away. Distract your brain by working on a few other questions, and then come back to the question that gave you trouble and see it with fresh eyes. The minute you run into any resistance, walk away. When you are left with two answer choices and you would swear that both are correct, walk away. When you have eliminated all of the answer choices, walk away. When a sentence isn't quite coming into focus, walk away. Do not continue to push on a question that is giving you problems. Walk away, distract your brain, and then go back.



Need more practice?

The Princeton Review's *Verbal Workout for the GRE, Fifth Edition*, includes hundreds of drill questions for the Verbal and Analytical Writing sections.

The time that you would otherwise spend struggling with a hard question, you can now invest in an easier one. Then, when you have two minutes left, use the Review screen to guess on all unanswered questions.

Got it? Now you're ready to move on and learn more about the types of questions you'll see on the Verbal section. Let's get cracking!

Summary

- The GRE Verbal section consists of two 30-minute sections, each containing 20 questions.
- The Verbal section is made up of Text Completion, Sentence Equivalence, and Reading Comprehension questions.
- Use the Two-Pass system along with your own Personal Order of Difficulty to focus your time on the questions you feel more comfortable working on.
- Success on the Verbal section of the exam involves using Process of

Elimination to eliminate “worse” answer choices.

- Vocabulary is an important aspect of success on the GRE Verbal section. Classify words on the GRE in three categories: words you know, words you kind of know, and words you’ve never seen before. Work on your vocabulary.

Chapter 4

Text Completions

If you took the SAT, you probably remember sentence completion questions. Well, they're back, retooled and renamed for the GRE. Text Completion questions test your ability to figure out which word or words best complete a given sentence or group of sentences. On the GRE, the sentence can have one, two, or even three blanks that you must fill. This chapter will show you The Princeton Review approach to Text Completions, a tried-and-true approach that will help you focus on exactly the parts of the sentences that you'll need to figure out the best answer. Along the way we'll provide you with some valuable

tips on using Process of Elimination to help you when you don't know all the vocabulary on a question.

THE FORMAT

On each Verbal section of the GRE you can expect to see about six Text Completions. Text Completion questions on the GRE will have one, two, or three blanks. One-blank Text Completions will have five answer choices, while two- and three-blank questions will have three choices for each blank.

Text Completion Directions

On the test, the directions will look something like the italicized blurb below. Make sure you learn them now so you don't waste time reading them on test day.

For the following questions, select one entry for each blank from the

corresponding column of choices. Fill all blanks in the way that best completes the text.

Some blanks are designed to test vocabulary, and others are designed to test comprehension. The vocabulary blanks have hard words; the context blanks often include prepositions and trigger words.

The blanks may operate independently or in conjunction with each other. If they operate in conjunction, the word you select for one blank will affect the meaning of the sentence, and therefore the word that might fit in another blank. This is a big help! When you find the word for one blank, it can help you determine all of the others.

often use difficult vocabulary words. Make sure you look up any words you don't know.

The first thing to note is that every answer choice will fit grammatically into the sentence, and quite a few of them will make a degree of sense.

The answer choices represent ETS's suggestions for what to put into the blank. The answer choices have been carefully selected and tested by thousands of students for their ability to tempt you into the wrong answer. As a test taker, don't trust their suggestions and certainly don't rely on them. It may seem like these questions are all about vocabulary, but the battle is generally won or lost before you ever get to the answer choices.

The "best" answer is what

ETS says is the “best”
answer.

The next step is to find the story. This step is what you should invest your time on for text completion questions. You must stay with the sentence or passage until the story that is being told is crystal clear in your head. If you go to the answer choices before the story is clear to you, the choices may change your perception of what the story should be. Don't even give them the chance. Stay with the passage until it is clear, or walk away and do a different question.

The answer choices represent ETS's suggestions for what to put into the blank. They are carefully selected to mislead you. Don't use them.

Here's an example:

Robert Ingersoll, although virtually unknown today, was _____ orator of the nineteenth century; people traveled hundreds of miles to hear his eloquent speeches.

a domineering
an eminent
an unobjectionable
a conventional
an execrable

Here's How to Crack It

1. **Set up your scratch paper with a column of answer choices, A through E.**
2. **Cover up the answer choices.** That's right, literally take your hand, put it on the screen, and cover up your answer choices.
3. **Find the story.** Who or what is this sentence about, and what are we told about this person or thing? In this case the sentence is about Robert Ingersoll. What are we told about him? He was some kind of orator, but we don't know what kind because that is the blank. What else are we told about him? The sentence is like a small reading composition passage, and you can use only things you are specifically told in the text. From this sentence, we know two things about him. Robert Ingersoll is *virtually unknown today* but, in the nineteenth

century, *people traveled hundreds of miles to hear his eloquent speeches.* That's what we know.

4. **Speak for yourself.** Use the information you're given in the sentence to come up with your own word for the blank. Be as literal as you can. If you can recycle part of the sentence, feel free to do so. In this case we can say that Robert Ingersoll was *a well-known* orator of the nineteenth century. Notice that we basically recycled the part of the sentence that stated that Robert Ingersoll is *virtually unknown today.*
5. **Use Process of Elimination.** Only when you have come up with your own word from the blank are you protected against the mind games in the answer choices. You now know exactly what the blank needs, and you therefore have a way of

evaluating the answer choices. Use your word as a filter to eliminate wrong answers. Use your scratch paper to track your progress. Don't get hung up on any individual answer choice at this stage. If you're not sure, just give it the maybe and move on. You are looking for a word that means something similar to *well-known*.

- Does *domineering* mean the same thing as *well-known*? No. Eliminate it.
- Does *eminent* mean the same thing as *well-known*? Possibly. Leave it in.
- Does *unobjectionable* mean the same thing as *well-known*? No. Cross it off.

- Does *conventional* mean the same thing as *well-known*? No. Cross it off.
- Does *execrable* mean the same thing as *well-known*? No. Cross it off.

Now check your scratch paper. You have four crossed-off answer choices and a maybe. This is why it doesn't pay to get too hung up on an answer choice in the first pass. If it could work, leave it in. If you're not sure, give it the maybe. Eliminate only those answer choices that are clearly wrong. Since *eminent* is the only choice left, select it as your answer. The best answer is choice (B).



What If You're Stuck Between Two Answer Choices?

Mark the question and walk away. Do two other questions and then come back. As always on the GRE, the minute you encounter the least resistance, walk away and come back. There can be only one correct answer to a Text Completion question. If two answers look correct, you may have misread something. The only way to reset your brain is to distract it by doing a few other questions and coming back.

Finding the Clue

Next, check your proof. The correct answer will always have proof in the passage. The proof is the part of the text that tells you what goes into the blank. We call this the clue. All Text Completion questions have

them. The clue is like an arrow that points to one answer choice and one answer choice only. If you are stuck between two, the clue will break the tie.

The clue is like an arrow that points to one answer choice and one answer choice only.

Let's break down an example:

Sophocles, who wrote the play *Oedipus Rex*, was one of the most _____ playwrights of ancient Greece.

famous
bombastic
critical
prolific
eclectic

What's your word for the blank? Not sure? That's because this sentence has no clue. Now try it again:

Sophocles, who wrote the play *Oedipus Rex*, was one of the most _____ playwrights of ancient Greece, completing 123 plays in his lifetime—double that of any of his contemporaries.

famous
bombastic
critical
prolific
eclectic

Now find the story. Who is the main character? Sophocles. What are we told about him? He wrote 123 plays—double that of any of his other contemporaries. Now it's easy to fill in the blank with your own word. Sophocles was a *productive*, *bountiful*, or *copious* playwright. He wrote lots of plays. When you go to the answer choices, you know you are looking for something that means the same thing or similar to *productive* or *lots of plays*, because your clue is, “completing 123 plays in his lifetime—double that of any of his contemporaries.”

Sophocles was certainly one of the most famous playwrights of ancient Greece. While this

may be true, your clue talks about the number of plays he wrote. It says nothing about how well known he was or is. While you might assume that a playwright who wrote so many plays must surely be famous, keep it literal. Assumptions will get you into trouble. The clue points to one answer choice and one answer choice only. Only *prolific* describes the number of plays written. The other four answer choices may fit the sentence, but none is the best answer choice.

More on the Clue

As you might have seen by now, finding the best answer on a Text Completion question depends on your ability to find the clue. Putting it another way, there is a word or group of words in the sentence that basically tells you what the right answer is. All you have to do is

find the clue and then know enough vocabulary to figure out the answer choice that matches the clue. Why would ETS put the answer to a question right in front of you? It has to, or otherwise it could reasonably be argued that there is more than one “best” answer to a question. ETS couldn’t have that—it would be deluged with complaints and challenges.

One important consequence of this fact is that the clue is everything when it comes to Text Completions. Find the clue and the correct answer will follow from it.

In some sentences, the clue will be fairly obvious, while in others, the clue will be harder

to spot. If you're having difficulty finding the clue, ask yourself the following questions:

1. Who or what is the blank referring to?
2. What other information is provided about this subject?

The answer to these questions is the clue. Let's try finding the clue in the following Text Completion question.

Because his one presidential term was marked by crisis and conflict, many historians consider the presidency of John Adams _____.

an expediency
an indulgence
a calamity
a regency
a sovereignty

What is the blank referring to? What other information is provided about it?

Don't go to the answer choices until you've come up with your own word for the blank!

Here's How to Crack It

First find the story. Who or what is the main idea? The presidency of John Adams. What are we told about his presidency? It was marked by crisis and conflict. In that case, how would historians view it? (Hint: Use

your clue.) Clearly, his presidency was *problematic* at best. Use the word *problematic* and compare it to the answer choices, marking your progress on your scratch paper as you go.

- Does *expediency* mean the same thing as, or is it similar to, *problematic* or *worse than problematic*? No. Eliminate (A).
- Does *indulgence* mean the same thing as, or is it similar to, *problematic* or *worse than problematic*? No. Eliminate (B).
- Does *calamity* mean the same thing as, or is it similar to, *problematic* or *worse than problematic*? Hmm, possibly. Leave it in.
- Does *regency* mean the same thing as, or is it similar to, *problematic* or *worse than problematic*? No. Eliminate (D).

- Does *sovereignty* mean the same thing as, or is it similar to, *problematic* or *worse than problematic*? No. Eliminate (E).

You've got one answer choice left on your scratch paper. No need for further work. You're done. The best answer is choice (C).



Now try using this technique to find the clue on the questions in the following practice drill.

A Quick Word About Your Words

Once you've found the clue in a sentence, you've done most of the heavy lifting. Don't strain yourself trying to come up with the perfect GRE word for the blank. Simple,

everyday words are perfectly okay, as long as they get the main idea of the word across. You can also use a phrase as your “word.” Really, just think of your job as filling in the definition of the word that goes in the blank. ETS will supply the big vocabulary words in the answer choices. So, you’re not trying to guess the answer. You’re just trying to come up with a word or phrase that will help you to find the answer.

Or, to make your life even easier, recycle! Many times, the clue itself can be recycled into your word for the blank.

Practice: Finding the Clue

Underline the clue in each of the following sentences. Then, think of your own word for the blank and write it down. Answers can be found in [Part V](#).

1 of 8

The _____ relationships in his life haunted Eugene O'Neill and are often reflected in the harrowing nature of many of his plays.

Be systematic! Ask yourself these questions.
To whom or what is the blank referring? What other info is provided about that subject?

2 of 8

Mount Godwin-Austen, more commonly known as K2, is the second highest mountain in the world, with its _____ peaks reaching more than 28,000 feet high.

3 of 8

A wind-chill warning is issued when the temperature is projected to reach minus 25 degrees Fahrenheit or lower, the point at which the cold has _____ effects on living creatures.

4 of 8

Divers still stumble across unexploded shells, 70-year-old _____ from World War II, in the waters outside Tokyo.

5 of 8

Although some people use the terms interchangeably, mastodons and mammoths were quite

_____ ; mammoths were hairy with long tusks, while mastodons had low-slung bodies and flatter skulls.

6 of 8

The mayor was definitely _____ ; he crafted his policies not with an eye toward their political consequences but instead toward their practical effects.

7 of 8

The first-year law student was amazed at the sheer _____ of the material he had to read for his

classes; he imagined that he would have to read for hours and hours each day to finish it all.

8 of 8

Our word “ghoul” is _____ from the Arabic word “Algol,” the name for the Demon Star, a star in the constellation Perseus.

Positive/Negative

In some cases, you might not be able to come up with a word, but you might know whether the word you're looking for is positive or negative. Look again at question 3 from the previous practice exercise:

A wind-chill warning is issued when the temperature is projected to reach minus 25 degrees Fahrenheit or

lower, the point at which the cold has _____ effects on living creatures.

You might not have been able to think of a word that fit in the blank, but you probably guessed that these very low temperatures don't help living creatures in any way. So you can eliminate any answer choices that contain positive or beneficial adjectives, right off the bat. Every little bit helps!

However, don't rely on positive/negative connotations unless you have no other option. ETS is, unfortunately, wise to the idea that test-takers think in terms of needing a positive or negative word. So, you may know that you need a positive word but when you look at the answers you discover that they are all positive words. So, it's better to recycle the clue if at all possible.

TRIGGER WORDS

Let's take a second look at the mastodon sentence from the clue drill.

Although some people use the terms interchangeably, mastodons and mammoths were quite _____; mammoths were hairy with long tusks, while mastodons had low-slung bodies and flatter skulls.

The first part of the sentence tells us that many people use the terms mastodon and mammoth interchangeably, and yet clearly the two are quite different. If our clue is *interchangeably*, the word in the blank will be opposite of the clue. The reason you know this is because of the trigger word, "Although."

1/0/1807

Triggers tell you whether the word for the blank should match the clue or be the opposite of the clue.

Think of it this way:

I won the lottery, *and*...

I won the lottery, *but*...

One of these stories is going to have a happy ending. One is not. Sensitize yourself to trigger words. They always play an important role in the story being told, and they always impact the meaning of the word in the blank.

Here are some of the most important Text Completion trigger words.

Change Direction		Same Direction
but	while	thus
although	however	similarly
unless	unfortunately	and
rather	in contrast	therefore
yet	despite	heretofore
previously		; (semicolon) and : (colon)

Note the colon and the semicolon in the preceding chart. A colon or a semicolon divides a sentence into two completely separate sentences; on Text Completion questions, you can expect both of these sentences to say the exact same thing. If that sentence has a blank in it, whatever is missing from one part of the sentence will be present in the other.

Practice: Clues and Triggers

Underline the clues and circle the triggers in the following sentences; then come up with your own word for the blanks. Recycle the clues if possible. Answers can be found in [Part V](#).

1 of 8

The star receiver is widely regarded as one of the top talents in the game, but his _____ performance as a rookie almost ended his career.

2 of 8

The prime minister received international _____ for her work; she brokered a diplomatic solution to a potential crisis.

3 of 8

While it is often assumed that drinking alcohol is detrimental to one's health, many studies have shown the _____ effects of having a glass or two of wine daily.

4 of 8

Despite the increasing technological connectivity of the modern world, many cultures still remain _____ from the global society.

5 of 8

Although many cultures view the toad as a symbol of ugliness and clumsiness, the Chinese revere the toad as a _____ symbol.

6 of 8

Stock analysts often use holiday sales to gauge future stock prices; thus, retail performance can be an important _____ of market trends.

7 of 8

It is somewhat ironic that while the population at large tends to have a negative view of the legal profession, individuals rarely display such _____ to their lawyers.

8 of 8

Methyl bromide is a pesticide that has devastating effects on insects; however, some believe it has the same _____ to humans.

You probably noticed that sentences can have multiple triggers. For example, a same-direction and a change-direction trigger will cancel each other out, while two change-direction triggers in the same sentence will also negate each other. Look at the following examples:

Although extremely poisonous, the puffer fish is also so rare that many people insist on eating the _____ creature.

In this sentence, there is one change-direction trigger, *although*, and one same-direction trigger, *also*. But the clue is that the fish is *extremely poisonous* and *rare*. We wouldn't want to use words like

nonpoisonous or *common* for the blank—the triggers cancel each other out.

It is somewhat ironic that while the population at large tends to have a negative view of the legal profession, individuals rarely display such _____ to their lawyers.

In this sentence, there are two change-direction triggers. The clue is “negative view,” and the word for the blank would also have to be something negative. Thus, the two change-direction triggers cancel out.

PUTTING IT ALL TOGETHER

Now you're ready to put all your techniques together. In the following drill, find the clue and any triggers. Come up with your own word for the blank, and then use POE to pick the best answer.

Remember to use your scratch paper. The place to invest your time on Text Completion questions is in finding the story, the clues, and the triggers. Do not look at the answer choices until you have a crystal clear idea of the story being told. Your first pass through the answer choices should take ten seconds or so. Don't get hung up on any of the answer choices. Either you know the word and it works, you know the word and it doesn't work, or you don't know the word. If you're not sure, or the word only kind of works, just give it the *maybe* and move on.

Practice your scratch
paper technique.

Because there are words missing, the story being told in the sentence may not be immediately clear. If you are having trouble bringing the story into focus, do not continue to push. You may have misread the sentence. Further time spent at this point is time wasted. Click the Mark button; then do a few other problems and come back. Trace your finger across the screen and make sure to read every word. If it is still not clear, walk away again.

Remember to skip and
come back if the sentence
is not immediately clear.

Do:

- Cover your answer choices.
- Find the story being told.

- Identify clues and note the direction of triggers.
- Walk away if the sentence is not clear.
- Come up with your own word for the blank.
- Work quickly through the answer choices, using your scratch paper to keep track of which ones are in and which ones are out.
- If you are stuck between two choices, walk away.
- Ask yourself the question “Does the clue point to my answer choice and my answer choice only?”



Premium Portal

Head to the Premium

Portal to watch videos and
review these strategies
and techniques.

Do Not:

- Stay with a sentence that you cannot fill in your own word for.
- Go to the answer choices and start plugging them in.
- Go to the answer choices until you have come up with your own word for the blank.
- Select an answer until you have a mark on your page next to each answer choice.
- Eliminate an answer choice unless you know exactly what that word means and have a good reason.

If your hand is not moving, you are getting caught thinking. Walk away and do a different question.

Text Completions Drill

Answers can be found in [Part V](#).

1 of 6

Despite the smile that spread from ear to ear, her eyes relayed a certain _____.

jubilance
sorrow
mischievousness
vision
liveliness

2 of 6

While grizzly bears have long, flat, and somewhat blunt claws, black bears have short, curved and _____ claws.

obtuse
abominable
barren
acute
fearful

3 of 6

One of social science's major themes is that of stability versus change; to what extent are individual personalities _____ or different over time?

transient
maladjusted
static
disturbed
discreet

4 of 6

The Erie Canal's completion caused _____ economic ripples; property values and industrial output along its route rose exponentially.

persistent
invaluable
incredulous
severe
prodigious

5 of 6

Voters have become so inured to the fickle nature of politicians that they responded to the levy of a new tax with _____.

amazement
stolidity
exasperation
alarm
perplexity

6 of 6

It is desirable to expand the yield of a harvest only when _____ additions in time, exertion, and other variable factors of production are not also required.

predestined
commensurate
analogous
deliberate
indeterminate

AN IMPORTANT WORD ABOUT USING POE

Sometimes you might do everything right—you might find the clue, identify the triggers, and come up with a great word for the blank—but you will still be stymied by the vocabulary that ETS uses in the answer choices and have no idea what any of the words means.



In these situations, it is important to make use of POE strategies:

1. **Never Eliminate a Word You Don't Know.** If you have any doubts about the meaning of a word, do not

eliminate it! Never get rid of an answer that just doesn't "sound good" in the sentence.

2. **Spend Your Time Working with the Words You Do Know.** Focus your energies on the words you do know, trying to match them with the clues in the sentence.
3. **Use Positive/Negative Associations if Necessary.** Be aggressive. If you know you need a positive word, eliminate any negative words.

Take a look at the following example:

Years of confinement in a sunless cell had left the prisoner wan and weakened, with a shockingly _____ appearance.

sidereal
boisterous
etiolated
singular
circumscribed

Here's How to Crack It

The clue in this sentence is “wan and weakened,” so we need to look for a word in the answer choices that means something like “wan and weakened.” However, the answer choices are a vocabulary hater’s nightmare (or a pleasant dream, for the word lovers in the audience!).

Let’s go through them. Choice (A) is a tough one—if you’re not sure of what this word means, you can’t eliminate it. Just leave it, and we’ll worry about it later. You might know that choice (B) means to be loud and

noisy; if so, you can eliminate this choice. The third choice is another difficult word, so let's move on to the fourth word. You might be aware that *singular* doesn't mean weak or wan; it means being one-of-a-kind or unique, so you can safely eliminate this choice. The final choice is *circumscribed*. Looking at this word, we might note it has the root *scribe* in it, which has to do with writing and drawing. Once again, it doesn't seem to match our clue so we can eliminate it. That leaves us with just two choices. At this point, you've done all you can do, so go ahead and pick one of the two. The important thing is to use careful POE to increase your odds.

Never eliminate words
that you don't know.

By the way, the correct answer is *etiolated*, which means to cause to appear pale or sickly.



TWO- AND THREE-BLANK TEXT COMPLETIONS

Remember that we said earlier that not all Text Completion questions on the GRE have just one blank: ETS will ratchet up the difficulty level of Text Completion questions by presenting you with sentences that have as many as two or three blanks.

Multiple blanks aren't that big of a deal. Use the same approach as you do for single blanks.

However, the techniques you've learned in this chapter constitute the basic approach to all types of Text Completions, no matter how fancy. Here's an example:

Federal efforts to regulate standards on educational achievements have been met by (i) _____ from the states; local governments feel that government imposition represents an undue infringement on their (ii) _____.

Blank (i)

receptivity
intransigence
compromise

Blank (ii)

autonomy
legislation
comportment

Here's How to Crack It

Step 1:

Engage the hand. Make a column on your scratch paper for blank i and blank ii.

Step 2:

Cover the answer choices and find the story. We have a semicolon that divides the sentence into two separate but equal parts. The first part says that the states have reacted in a particular way to federal regulation, but we don't know what that way is, so let's check the second part. In the second part we're told that the local governments feel that the regulation is an "undue infringement" and an "imposition."

Step 3:

Come up with your own words for the blanks. For the second column, use the information in the story to come up with your own word. Federal standards would impact a state's ability to decide standards for itself, so try something like "rights" or "decision making" and jot it down on your scratch paper. For the first blank, if the states feel as though the federal government regulations are an *imposition* and an *infringement*, the

states would likely *resist* those regulations. So, use *resistance* as your word for the first blank.

Step 4:

Use Process of Elimination. Put down an “x” for any answer choice that does not work. Under the first blank, *receptivity* and *compromise* are both gone because they don’t match *resistance*. The middle word stays; even if you don’t know what it means, it doesn’t matter. No need to spend any more time on it than that. For the second blank, the word *legislation* is tempting, since we’re talking about governments, but it’s meant to be tempting. Our words are *rights* and *decision making*, neither of which means *legislation*, so put an “x” in the middle slot. *Comportment* means the way you carry yourself. That’s not even related, so give that one an “x” too. *Autonomy* is the closest to *rights* or *decision making*; in fact, it fits quite well.

We have an answer. When you're done, your scratch paper should look something like this:

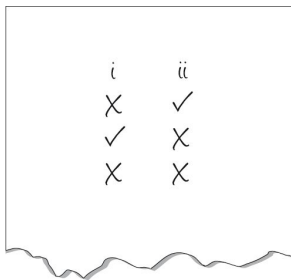

Let's try another one.

Don't try to deal with all the blanks at once. Take them one at a time.



Many popular musicians have (i) _____ new digital technologies that allow them unprecedented control over their music. These musicians use computers to (ii) _____ and modify their songs, resulting in a level of musical precision often unattainable naturally. Of course, though, as is often the case with new technologies, some traditionalists (iii) _____ these developments.

Blank (i)

incorporated
synthesized
alleviated

Blank (ii)

energize
delineate
recast

Blank (iii)

balk at
revel in
retaliate at

Can you come up with your own word for the blank?
Are there other words that could also work?

Here's How to Crack It

Don't be intimidated by the multiple-blank sentences; just try to isolate each blank and apply the strategies we taught you. You don't have to work the blanks in order: Start with whichever one of the blanks seems easiest to you.

For this one, let's start with the second blank. The clue is *modify* and the trigger is *and*, so we need to find a word that's similar to *modify*. Let's go with *alter*. Now use POE and look at the answer choices in the second box. *Energize* doesn't match our word, so eliminate it. Neither does *delineate*, which means to outline or to depict. That leaves us with *recast* for the second blank.

You may have noticed that the first blank is related to the second blank. If the musicians are modifying their songs and also have *unprecedented control* over their modification,

we need a word like *using* or *embracing* for the first blank. The only answer choice in the first box that's even close to this word is *incorporated*.

Finally, we move on to the last blank. The clue here is that we're dealing with *traditionalists*. How would traditionalists react to these *new technologies*? They would probably react negatively, so we need a word like *reject* or *dislike* for the third blank.

Look at the choices in the final box. *Revel in* is a positive sentiment, so we can eliminate it. *Retaliate at* is definitely negative, but there is nothing in the sentence that indicates that the traditionalists are taking action against those using the new technology, or the new technology itself! Thus, *balk at*, which means to resist or object to, is the best answer.

RELATIONSHIP BETWEEN THE BLANKS

Some two- and three-blank Text Completions hinge on the use of trigger words, and don't contain really strong or obvious clues that you can rely on. For example, look at the following sentence:

Jenkins is an artist known for engendering strong reactions in his viewers; in fact, some of his more (i) _____ paintings have caused viewers extreme (ii) _____.

Blank (i)

ominous
accomplished
innovative

Blank (ii)

discouragement
discomposure
resoluteness

Here's How to Crack It

The minute you recognize that this is a relationship between the blanks question, make your set-up on your scratch paper. It should look like this:

6	A	a
		b
		c
	B	a
		b
		c
	C	a
		b
		c

You are not looking at three individual options for the first blank and three individual options for the second blank; you are looking at nine possible combinations, only one of which will work. The first blank will depend entirely on the second blank. We know for sure that the two must work together. In this case, there is nothing to do but Plug In and eliminate. If the first word is *ominous*, the second word must describe a strong negative reaction. *Discouragement* doesn't quite

make sense, so cross off *a*. *Discomposure* is possible, so give it the maybe and give the *A* in the first column the maybe, because there is at least one combination with this word that could work. *Resoluteness* is positive, so you can eliminate it.

Now try *accomplished*. If this is the first word, we need a strong positive for the second word, so you can eliminate *a* and *b*. *Resoluteness* does not really follow from *accomplished*, so cross off *c* in the second column and *B* in the first column.

Now try *innovative*. With this as your first word, we need a strong positive for the second word, so you can eliminate *a* and *b*. *Resoluteness* does not really follow from *innovative*, so cross off *c* in the second column and *C* in the first column.

Now look at your scratch paper. At this point, your scratch paper can answer the question for you. There is only one possible combination that could work. Pick *ominous* and *discomposure*, and you are done. Your scratch paper should look like this:

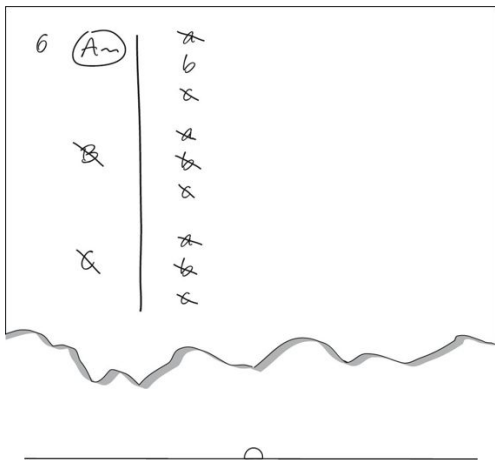

If there is no clear clue, look for the relationship between the blanks.

THE LAST WORD—VOCABULARY

As we've seen, using the techniques, including POE, can help you a great deal on a great majority of Text Completion questions. However, on some questions you hit the “vocabulary wall”—the point at which you're stuck because you don't know the meaning of the words in the question. The only cure for this predicament is to improve your vocabulary as much as you can before test day. Memorizing the Hit Parade (in [Chapter 8](#)) is a good start, but there are myriad other ways of increasing your vocabulary.

Study vocabulary
every single day.

Here's the moral of the story: As you prepare for your GRE, try to keep learning new words

every day, in whatever way works best for you.



You're In the Home
Stretch (of This Chapter)

You've tackled this Text Completions chapter masterfully!

Complete the Text Completions Practice Set and then give yourself a study break. Grab a snack, take a walk, and let these lessons sink in before you jump into the next chapter.

Text Completions Practice Set

Answers can be found in [Part V](#).

1 of 10

With global interconnectedness on the rise, the conviction of the United States to remain neutral in World War I seemed ever more

_____.

presumptuous
futile
contemptuous
pragmatic
admirable

2 of 10

Upon visiting the Middle East in 1850, Gustave Flaubert was so _____ belly dancing that he wrote, in a letter to his mother, that the dancers alone made his trip worthwhile.

overwhelmed by
enamored of
taken aback by
beseached by
flustered by

3 of 10

The human race is a very (i) _____ species, as the facade of calm that covers our anxiety and (ii) _____ is flimsy and effortlessly ruptured.

Blank (i)

fragile
purposeful
daring

Blank (ii)

terror
vulnerability
humor

4 of 10

The practice of purchasing books was primarily a (i) _____ of the well-to-do until the late 1800s, when the increased popularity of dime novels, the expansion in the number of bookstores, and the introduction of the paperback made books (ii) _____ the average man.

Blank (i)

conduit
prerogative
plight

Blank (ii)

dislikable to
excitable to
attainable by

5 of 10

Increasingly, the boundaries of congressional seats are drawn in order to protect incumbents, as legislators engineer the demographics of each district such that those already in office can coast to (i) _____ victory. Of course, there is always the possibility that the incumbent will face a challenge from within his or her own party. Nevertheless, once the primary is over, the general election is (ii) _____.

Blank (i)

an ineluctable

an invidious

a plangent

Blank (ii)

seldom nugatory

remarkably contentious

merely denouement

6 of 10

While more (i) _____ professors continue to insist that video games will never be a proper object of study, the rising generation of more heterodox academics is inclined to view such talk as positively (ii) _____.

Blank (i)

pedantic
progressive
erudite

Blank (ii)

antediluvian
pusillanimous
jejune

[7](#) of 10

Political predictions generally prove fairly accurate when the presumption that the future will be similar to the past is (i) _____. In periods with substantial (ii) _____ in the political world, however,

predictions can be (iii)
_____ wrong.

Blank (i)

disproved
stipulated
fulfilled

Blank (ii)

upswings
insurgencies
changes

Blank (iii)

thoughtfully
perilously
carelessly

8 of 10

Water is one of the few molecules that is less (i) _____ as a solid than as a (ii) _____; if you need (iii) _____, just look at the floating ice in your water glass.

Blank (i)

intriguing
dense
aqueous

Blank (ii)

vapor
plasma
liquid

Blank (iii)

an illustration
an imbibement
a discordance

[9](#) of 10

As Molly was (i) _____ Spanish with her friends before their trip to Chile, she discovered that although she could comprehend her friends, she could not (ii) _____ her thoughts in the (iii) _____ language.

Blank (i)

mastering
disregarding
practicing

Blank (ii)

acknowledge
articulate
disencumber

Blank (iii)

inherent
objective
unfamiliar

[10](#) of 10

People accustomed to thinking that the human lifespan (i) _____ the outer bounds of animal longevity tend to dismiss tales of musket balls being found in the shells of living turtles. Samantha

Romney, however, argues that while such stories may be (ii)

_____, some turtles do indeed exhibit a phenomenon known as “negligible (iii) _____,” showing no signs of aging even as they pass the two-century mark.

Blank (i)

belies
demarcates
antedates

Blank (ii)

apocryphal
authentic
heresy

Blank (iii)

rejuvenation
superannuation
senescence

Summary

- In Text Completion questions, come up with your own word for the blank, using the clues and triggers in the sentence.
- If you can't find the clue, ask yourself these questions: To whom or what is the blank referring? What other information is provided about that subject?
- Trigger words tell you whether the word in the blank should be similar to the clue or opposite of the clue.
- After you've come up with your own word for the blank, use POE to eliminate words that aren't close to your

word. Don't eliminate words if you are unsure of their meanings. Focus on the words you do know.

- If the sentence has two or three blanks, do the blanks one at a time. Pick the easier (or easiest) blank to start with, find the clue, come up with a word, and use POE. Then repeat for the remaining blanks.
- Keep studying vocabulary. Make sure to look up any words you don't know. We recommend flashcards, for easy vocabulary review on-the-go.

Chapter 5

Sentence Equivalence

This chapter details a variation on the Text Completions you learned about in the prior chapter. Sentence Equivalence questions require you to find the best word to complete a sentence. For these questions, however, you'll have to pick the two answers that best complete the sentence; this means the two correct answers will be synonyms. Because both words create sentences that are equivalent—both have the same meaning—we refer to these types of questions as Sentence Equivalence questions. This chapter shows you how to apply the strategies you learned last

chapter and use Process of Elimination to answer these questions.

WHAT YOU WILL SEE

Remember in the last chapter when we alluded to the “other” type of Text Completion question? Well, now it’s time to look at these questions in a little more detail. These questions are somewhat similar to the one-blank Text Completion questions we worked on in [Chapter 4](#). However, they are different in several major respects. First, these questions always have six answer choices, not five. Second, you need to pick the two answers that complete the meaning of the sentence in the same way. Generally this will mean synonyms, but they don’t need to be exact synonyms, as long as the meaning of the sentence stays the same.

Here's What the Directions Will Tell You to Do:

For the following questions, select the two answer choices that, when used to complete the sentence, fit the meaning of the sentence as a whole and produce completed sentences that are alike in meaning.

You should expect to see about three to five Sentence Equivalence questions on each GRE Verbal section.

Now, here's what a Sentence Equivalence question looks like:

Anthropologists contend that the ancient Mesopotamians switched from grain production to barley after

excessive irrigation and salt accumulation made the soil _____ grains.

- indifferent to
- inhospitable to
- unsuitable for
- acrimonious to
- benignant to
- inured to

How does this question differ from the Text Completion questions in [Chapter 4](#)?

Our goal is to choose the TWO answers that produce sentences with similar meanings. In other words, you'll be clicking on two answer choices instead of one.

APPROACHING SENTENCE EQUIVALENCE

Besides being similar in appearance, Sentence Equivalence questions are also very similar to Text Completions in their structure. Sentence Equivalence questions have clues and triggers, just like the sentences we looked at in [Chapter 4](#).

However, Sentence Equivalence questions are even more vocabulary-driven, because they require you to find two answers that are synonymous.

Tackling Sentence Equivalence

The approach to Sentence Equivalence is almost exactly the same as Text Completions.

1. **Set Up Your Scratch Paper.** You will see three to five Sentence Equivalence questions in a row. Each has six answer choices, so set up your scratch paper. If you don't, you will try to answer the question in your head rather than on your scratch paper. Doing questions in your head leads to harder work, wasted time, and more errors.
2. **Find the Story.** *Whom* or *what* is the sentence talking about, and what are you told about that person or thing? Pay close attention to triggers; they

are always significant clues to the direction of the sentence.

3. **Speak for Yourself.** Come up with your own word or phrase for the blank. It doesn't have to be a big ETS word. Any word or words will do as long as you keep it literal and don't add any concepts or ideas that aren't already in the sentence. If you can recycle your clue, do so.
4. **Use Process of Elimination.** Get your hand moving. Your pass through the answer choices should take 10 or 15 seconds only. Either you know a word and it works, you know a word and it doesn't work, or you don't know the word. If you're not

sure, don't sit and think about it; give it the *maybe* and move on. You cannot eliminate a word if you don't know what it means.

Remember that the meaning of the sentence must stay the same. For that to occur, the meaning of the sentence must be clear to you. Just as with Text Completions, the place to invest your time is in the sentence.

You cannot go to the answer choices until you have a crystal clear understanding of the story being told by the sentence.

The good news is that you don't have to do this all in one go. Some of the sentences are tough, and, of course, there is information missing. If the sentence does not come into focus after the first or second reading, walk away. Mark that sentence and go do some easier ones. Often you will find that, when you return to a sentence after having done a few others, the meaning suddenly becomes clear. Also, the time you would otherwise have spent staring at a difficult problem in frustration, you have now spent getting a few other questions correct. You should always be spending your time *doing*, not *thinking*.

Take a look at the grey box for the basic approach to Sentence Equivalence questions, which is identical to the method for Text Completions you already learned. Then try it out on the question we just saw:

Anthropologists contend that the ancient Mesopotamians switched from grain production to barley after excessive irrigation and salt accumulation made the soil _____ grains.

- indifferent to
- inhospitable to
- unsuitable for
- acrimonious to
- benignant to
- inured to

Here's How to Crack It

First, look for the clues and triggers in the sentence. In this sentence, the clue is that the Mesopotamians “switched from grain to barley.” For this reason, the word in the blank

has to mean something along the lines of *unsuited for*. Now it's a matter of going to the answers and using POE.

Answer choice (A) doesn't match the clue; eliminate it. Choices (B) and (C) are both pretty close to the word we came up with, so leave them. How about the remaining choices? *Acrimonious to*, in choice (D), means using sharp language, so that doesn't make sense. Choice (E), *benignant to*, means kind or gracious, so you can eliminate that as well. And finally, *inured to* means to become accustomed to something bad. That doesn't match our choices either, so eliminate it. The best answers are (B) and (C).

Keep in mind that even if you don't know what *acrimonious* or *inured* means, you can probably still get the correct answer. How? By POE of course! All the guidelines we talked about for Text Completions still apply

here. As we said in [Chapter 4](#), you should always work with the words you do know and leave the unknowns alone. Your scratch paper can answer the question for you. If you have two words that work and two question marks, you're done. Pick the ones that work.



Sentence Equivalence Drill

Work the following questions, using the same approach you used for Text Completions. Check your answers in [Part V](#) when you're done.

1 of 5

To any observer, ancient or _____, the night sky appears as a hemisphere resting on the horizon.

- antiquated
- perceptive
- modern
- astute

contemporary

archaic

[2](#) of 5

Researchers interested in the nature versus nurture debate use identical twins who were separated at birth to explore which personality characteristics are _____ and which arise through experience.

intractable

nascent

erudite

innate

predilection

inborn

3 of 5

The eccentric Canadian Prime Minister, Mackenzie King, often used séances to contact his dead pet dog for advice; despite this

_____ behavior, the public had so much confidence in his ability as a leader that he was in power for 22 years.

- capricious
- lackluster
- poised
- unconventional
- repulsive
- decorous

4 of 5

The circulation of the blood makes human adaptability to the _____ conditions of life, such as fluctuating atmospheric pressure, level of physical activity, and diet, possible.

- inveterate
- dynamic
- timorous
- cowed
- turgid
- oscillating

[5](#) of 5

Arriving in New Orleans days after Hurricane Zelda had passed and without an adequate number of vehicles of its own, the armed forces

began to _____ any working form of transportation they could find, including a bus that had been chartered at great expense by a group of tourists.

- repatriate
- commandeer
- extradite
- interdict
- expurgate
- appropriate



PROCESS OF ELIMINATION STRATEGIES

With six answer choices in front of you, there are many opportunities to make effective use of Process of Elimination. Here are a few things to look for.

Positive and Negative Words

One strategy that you can use to answer Sentence Equivalence questions is to separate the answer choices into positive ones and negative ones. Remember how we talked about positive and negative words in [Chapter 4](#)? You don't need to know the dictionary definition of a word if you can somewhat confidently identify the word as being

positive or negative. Here's how you would use them on this type of question:

Despite the implications of their noble status, many aristocrats were virtually penniless and lived in a state of _____.

- indigence
- opulence
- eminence
- penury
- depravity
- complacency

Can you identify any of the words as positive or negative?

Here's How to Crack It

The trigger in this sentence, *despite*, tells us that we need a word that has a meaning that's opposite to *noble status*. Also, the clue states that the aristocrats were *virtually penniless*. Therefore, we only want to consider negative words.

Let's look at the choices and see if we can figure out if they're positive or negative. The third word is *eminence*. Can you figure out if this is a positive or negative word? You might have heard the word *eminent* before, as in *an eminent doctor* or *an eminent scientist*. This is a good word, so let's eliminate choice (C). Choice (F) is *complacency*. Are there any other words you've seen that remind you of this word? You may have heard the word *placate* before. This word means to please someone. Or, how about the word *placid*? That describes someone who is calm and satisfied. Each of these

words—*complacent*, *placate*, and *placid*—share the same root, *plac-*, which means to please. So it looks like we can eliminate choice (F).

We've eliminated two words, but we've still got some tough ones left. Don't give up! Look at choice (E). *Depravity* is certainly a negative word, but does it match the clue? Would you describe a penniless person as depraved? Not likely, so we can eliminate choice (E) as well. That leaves only three choices. If you were to guess at this point, you'd have a one-in-three chance of guessing correctly. Of course, if you know the meaning of just one of the remaining three words, you're in pretty good shape as well. For example, if you know that *opulence* is a positive word, then you've got the answer—it has to be choices (A) and (D), which both mean to be poor. If you know the meaning of either choice (A) or choice (D), then you have a

fifty-fifty chance of guessing correctly, which is not too bad at all.

Word Roots

Learning word roots gives you the opportunity to get more bang for your vocabulary buck. You'll probably never know all the words the GRE will throw at you, but by mastering some common roots, you might know just enough about a mystery word to determine whether you should keep it or get rid of it. Here are some common roots to get you started:

- *Ben/bene*—good. Examples: *benefit, benevolent, benefactor*

- *Mal/male*—bad. Examples: *malign, malevolent, malediction*
- *Animus*—spirit, soul. Examples: *animate, magnanimous*
- *Cise/cide*—cut. Examples: *excise, homicide, circumcise*
- *Gen/gene*—type, kind. Examples: *genesis, generate, homogenous*
- *Port*—carry. Examples: *export, transport, porter*
- *Andro/anthro*—man, person. Examples: *anthropology, android*

Obviously, this list barely scratches the surface of word roots but you get the idea. Look for roots in your Hit Parade words (in [Chapter 8](#)) and any other new words you learn.

Let's move on to another strategy.

Synonym/No Synonym

If you're pretty familiar with the words in the answer choices, you can use your vocabulary to eliminate certain answers and to lump certain other answers together. You do this by looking at the choices and first eliminating any answer choice that has no synonym among the remaining choices. You can also identify pairs of words as synonyms and lump them together.

Consider this example:

Because mercury has a variety of innocuous uses, including in thermometers and dental fillings, few people realize that it is one of the

most _____ substances on the planet.

- acidic
- irritating
- mundane
- deleterious
- disagreeable
- pernicious

Here's How to Crack It

Work with the answer choices to see if you can lump them into synonym/no synonym groupings. First, eliminate choices that have no synonyms among the answer choices.

Start by eliminating choice (A). None of the other choices are similar in meaning to the word *acidic*, so choice (A) cannot be the

correct answer. The same goes for choice (C). There is no other answer choice that's similar in meaning to *mundane*, so eliminate it.

Next, group the remaining choices together. You might notice that choice (B) and choice (E) are synonyms for each other, which means if you select one of them, you'll have to select the other. The same logic applies to choices (D) and (F). With four answer choices left, you now have a fifty-fifty chance of getting the question right: You know that the correct answer is either (B) and (E) or (D) and (F).

The clue in this sentence is *innocuous uses* and this sentence also contains a trigger—"few people realize." We're looking for a word that means the opposite of *innocuous*, which means harmless. Choices (D) and (F) are the best answers.

IF YOU'VE NEVER SEEN THE WORD BEFORE

No matter how expansive your vocabulary is, at some point you'll probably run across a word you've never seen before. Don't panic! Just work with the words you do know and rely on your old friend POE. Take a look:

Despite their outward negativity,
many a cynic harbors an inner faith
in the _____ of mankind.

- benevolence
- precocity
- parsimony
- ignobility

antipathy

probity

There's no substitute for a strong vocabulary.

Here's How to Crack It

First things first. The clue for this sentence is *outward negativity*, and we also have the trigger word *despite*. Thus, we need a word meaning the opposite of negativity. This question definitely calls for a positive word. That's the easy part; now we have to deal with a number of difficult words in the answer choices. Do the best you can with the words you know and leave the words you don't know alone. Choice (A) looks like a keeper. The prefix *bene-* is used in tons of positive words—*benefit*, *benefactor*, *benign*, *beneficent*. Choice (B) is a tough one, so let's leave it for now. The same goes for choice

(C). Choice (D) isn't so bad. It has the root word *noble* in it, which is certainly a good word, but we've added the prefix *ig-* to the word. That's probably a bad thing. We should eliminate this choice. Similarly, choice (E) has the prefix *anti-*. That means against or opposite, which is also generally bad. So we should eliminate this choice as well.

So far, choice (A) is definitely in, while choices (D) and (E) are definitely out. Even without knowing either of the words in choices (B), (C), and (F), we would still have a one-in-three chance of guessing correctly—the answer is either (A) and (B), (A) and (C), or (A) and (F). Not too bad for knowing only four of the six words. If we want to take our POE a step further, we could probably even eliminate choice (B). The word has the prefix *pre-* in it, which means *before*. That doesn't really have much

to do with good or bad, so we could probably eliminate it. That gives us a fifty-fifty chance of guessing correctly. The actual answer is choices (A) and (F). *Probity* means good behavior, while *parsimony* means stinginess.



Sentence Equivalence

Practice Set

Work the following questions, using all the techniques you've learned for Sentence Equivalence. Check your answers in [Part V](#) when you're done.

1 of 5

Possessed of an insatiable sweet tooth, Jim enjoyed all kinds of candy, but he had a special _____ for gumdrops, his absolute favorite.

- container
- affinity

- odium
- nature
- disregard
- predilection

[2](#) of 5

Although the Wright brothers first attempted flight in 1901 was a _____ and subsequent efforts similarly ended in failure, they persisted and ultimately made the first successful airplane flight in 1903.

- fiasco
- debacle
- hindrance
- feat

- triumph
- precedent

3 of 5

The fuel efficiency of most vehicles traveling at speeds greater than 50 miles per hour _____ as the vehicle's speed increases, due to the increased aerodynamic drag placed on the vehicle.

- equalizes
- adapts
- stabilizes
- diminishes
- increases
- wanes

4 of 5

Despite the vast amount of time Francis dedicated to learning six different languages, he was _____ communicator; his mastery of vocabulary and grammar failed to redress his inability to construct cogent prose.

- a florid
- an inept
- a prolific
- an astute
- a morose
- a maladroit

5 of 5

The twins' heredity and upbringing were identical in nearly every

respect, yet one child remained unfailingly sanguine even in times of stress while her sister was prone to angry outbursts that indicated an exceptionally choleric _____.

- genotype
- environment
- physiognomy
- incarnation
- temperament
- humor

Summary

- The approach for Sentence Equivalence questions is the same as it is for Text Completions. Ignore the answer choices, look for clues and triggers, and fill your own words in for the blanks.
- Use positive and negative associations to eliminate answers.
- Try to group answers choices with their synonyms. Eliminate any choices that don't have a synonym.
- Keep working on vocabulary every day!

Chapter 6

Reading Comprehension

Reading Comprehension questions on the GRE can be quite deceptive. On one hand, the answer to each question is somewhere in the passage. On the other hand, ETS is really good at crafting answers that seem right but are, in fact, wrong. This chapter will teach you the best way to approach the reading passages on the test and how to attack the questions. Furthermore, you'll learn how to use Process of Elimination to get rid of wrong answers and maximize your score.

WHAT YOU WILL SEE

On the GRE, you'll be presented with about eight reading passages, varying in length from a mere 12 lines to more than 50 lines. After each passage, you'll be asked to answer a number of questions. Your task is to choose the best answer to each question based on what is stated or implied in the passage. Translation: The correct answer to every question is somewhere in the passage. In fact, think of Reading Comprehension questions as an open-book test. Your goal is simply to locate the answer within the passage.

Reading Comprehension
is like an open-book test:
The correct answer to
every question is somewhere
in the passage.

Reading Comprehension and the Computer

Reading Comprehension questions are presented on a split screen. The passage is on the left side and stays there while you work on the questions; you may have to use the scroll bar to read the whole passage. The questions appear one at a time on the right side. It's very important to practice reading comprehension on the computer with The Princeton Review's online practice tests or ETS's free *POWERPREP II* software (see [Chapter 1](#)), because you'll have to get used to not being able to circle or underline words, bracket text, write notes in the margin, and so on. But you can start practicing good habits right now. As you work through this chapter, and any time you practice reading comprehension on paper, don't allow yourself to write on the passage. Anything you write must be written on scratch paper. In your preparation for the GRE, never give

yourself a crutch you won't actually have when you take the real test.



Online Practice Tests

Where are those online practice tests, you ask? They're in your Student Tools found at

www.PrincetonReview.com. You must have registered your book by now, so log-in will be a breeze!

Let's get started.

READING AND THE GRE

Although it might seem that Reading Comprehension questions shouldn't be very hard, ETS makes these types of questions difficult by exploiting some common assumptions.

The reading skills you'll need to use for Reading Comprehension questions on the GRE are quite different from the ones you use in your everyday life. The biggest challenge will probably be the limited time you have to answer the questions.

For one thing, ETS (intentionally) chooses reading passages that are complicated and are concerned with unfamiliar and, in some cases, intimidating topics, hoping that you'll have a tough time absorbing the entirety of the passage in the short amount of time they give you. In many cases, that is exactly what

happens: Test takers spend too much time trying to understand what they've read and not enough time working on the questions.

ETS also hopes that you will overanalyze the text. This level of critical thinking is wholly appropriate for most types of academic reading, but on the GRE it only leads to trouble. The way to crack the reading portion of the GRE is to read less into the passages, not more.

Although it may sound counterintuitive, in some ways the passage itself is the least important part of Reading Comprehension questions. This is for a simple reason—you don't get any points for reading the passage, and the only way to do well on the GRE is to amass as many points as possible.

The Directions

These are the directions as they will appear on your GRE:

Directions: Each passage in this group is followed by questions based on its content. After reading a passage, choose the best answer to each question. Answer all questions following a passage on the basis of what is stated or implied in that passage.

Here are *our* directions:

Directions: This is not really a test of reading, nor is it a test of comprehension. It's a

treasure hunt! You can find all of the answers in the passage.

Okay, you're ready to take a look at our approach to Reading Comprehension questions.

READING COMPREHENSION: THE BASIC APPROACH

1. **Attack the Passage.** This step will vary slightly based on the length of the passage you're dealing with, but in each case, the goal is to read less, not more.
2. **Size Up the Questions.** Reading Comprehension questions on the GRE can ask you to do a variety of things. Make sure you know what the question's asking you to do.
3. **Find and Paraphrase the Answer.** This is the key. Always return to the passage to find your answer; never answer questions from memory!

4. **Use Process of Elimination.** You can use a number of helpful POE guidelines on Reading Comprehension questions. We'll go over these in detail in a moment.

Let's look at each step in some more detail.

ATTACK THE PASSAGE

Imagine you drop out of an airplane and land on a random college campus. You walk into a random building, pop into the first lecture hall you see, and stand in the back for 10 minutes. When you come out, someone asks you a bunch of questions about what you've just heard. That is what reading comprehension is like on the GRE. You don't pick the topic; you don't start from the beginning; there is no title, no outline, and no table of contents. You are not in control.



Remember

You don't have to read every single word of

the passage in order to answer the questions.

The creators of the GRE are going to give you short and long passages filled with tons of information that you will never be tested on. They will try to suck you into these dense, badly written science or humanities passages in order to get you to waste time and to confuse you with useless information. Your job is to read as little of the passage as you need to get started on the questions and then to let the questions tell you which facts to care about. To get started on the questions, you need to know only the main idea of the passage, the structure, and the tone.

Fortunately, you know most of this already. The truth is that all GRE passages are really about one of two things: a problem or a change. You may think a passage is about art history or geology or different kinds of rocks

on Jupiter, but really, it's either about a problem or a change.

Furthermore, once you know whether it is about a problem or a change, you even know what the passage is likely to cover.

Problem passages cover these questions:

1. What is the problem?
2. What caused the problem?
3. What are the effects of the problem?
4. Are there any solutions?

Change passages cover these questions:

1. What was the old way?
2. What is the new way?

3. What caused the change?
4. What are the effects of the change?

Knowing how passages are organized will change the way you read. This information puts you back in control by allowing you to categorize the information you're given and to anticipate what is coming next. *Remember:* On the first reading, you just need the basics. Don't get sucked into details you don't need to know.

Once you know whether a passage is about a problem or a change, you just need enough information to answer the four standard problem or change questions. Feel free to skim the rest. If you are asked a question

about something you skimmed over, you can always go back to find it.

There is one golden rule of reading comprehension: Always go back to the passage to find proof. If you cannot put your finger on a line that proves your answer choice, you should not pick it.

When you see reading comprehension passages, practice categorizing them as problem or change, and then practice anticipating what each paragraph is going to be about. Once you get good at this, you will find that *you* are in control, not them.

Try reading the following passage:

Prior to 1735, there was no legal precedent for freedom of the press. The constitutional concept of freedom of the press

traces its origins to 1735 and the libel trial of John Peter Zenger. Zenger, born in Germany, emigrated to America in 1710 and established *The New York Weekly Journal* in 1733. The *Journal* starkly opposed the policies of New York governor William Cosby and while Zenger did not write the majority of the critical pieces, he was arrested on libel charges in 1734. In the ensuing trial, widely followed by the populace, Zenger was defended by Andrew Hamilton, a Pennsylvania lawyer who was brought in after Cosby disbarred all the New York lawyers who offered to defend Zenger. Hamilton's brilliant defense of Zenger was predicated

What are the effects of the change?

Yes, the preceding passage is about freedom of the press, but it's really about a change. According to the old way, there was no freedom of the press, and reporters could be arrested. After the adoption of the new way, reporters writing verifiable facts could not be charged with libel. The cause of the change was the trial of John Peter Zenger, and the effect of the trial was the precedent of freedom that eventually became enshrined in the U.S. Constitution some 57 years later.

If you said that a lack of freedom of the press was a problem, don't worry. It was. The important thing is that you were the one in charge when you were reading, and you were the one asking the questions. Instead of passively letting information wash over you,

hoping the important parts of the passage would stick, you became an active reader.

Now try again on a longer passage. Remember not to get bogged down by the details in the passage. Read for evidence of what the author thinks. Important statements in the passage contain the author's opinions, recommendations, and conclusions.

Stay focused on finding the main idea as you read.

What was it about Oscar Wilde's only novel, *The Picture of Dorian Gray*, that caused it to create such an uproar when it was published in 1891? While critics attacked the quality of Wilde's work, lambasting its plot as "incurably silly" and chiding the writer for using

prose that was “clumsy” and “boring,” these overt denunciations of the formal elements of Wilde’s work merely masked the true concerns of many nineteenth-century critics. What these critics were actually railing against was the thematic content of Wilde’s work, specifically his illustration of a lifestyle devoted to useless beauty. For many a nineteenth-century moralist, *The Picture of Dorian Gray* was nothing more than a primer for spiritual depravity. Wilde’s ultimate sin was not his clunky plot or his sometimes cloying prose; it wasn’t even his disregard for the time-honored tradition of English propriety. It was instead his leniency toward his

What is the problem?

What caused it?

What are the effects?

Are there any solutions?

Here we have a longer passage about the critical response to Oscar Wilde's *The Picture of Dorian Gray*. You know that it is a problem in the very first sentence when you are told that the novel created "an uproar" and in the second sentence when you are told that critics "attacked" it. The cause of the problem doesn't come until the last third of the passage. The protagonist was a hedonist, but Wilde did not punish his character

for his sins. The effect of this problem was the outrage from critics. No solution is offered. Everything else is just details. Trigger words such as “Wilde’s ultimate sin” and “it was instead ...” are good indicators that something important is being said.

Purpose

You will often see questions that ask about an author’s purpose—that is, why the author bothered to write the passage, paragraph, or sentence at all. Purpose can be summed up with the acronym PRICE. The purpose of a paragraph, passage, or even an individual sentence is to Predict, Recommend, Inform, Correct, or Evaluate.

Most passages or paragraphs simply inform. Whenever an author begins to offer an opinion, however, he or she may be evaluating an argument, correcting a misperception,

predicting an outcome, or even recommending a behavior.

With longer passages, it is helpful to go paragraph by paragraph and note the subject (the old way, the new way, the nature of the problem, and so on) and the purpose of each paragraph. Jot this information down on your scratch paper. Doing so will force you to actively assess each paragraph and will give you a map that you can use to find the answers for specific questions.

Make sure that you scroll down as far as you can, to guarantee that you see the entire passage.

This passage contains a lot of details. Don't get bogged down in them!

Here is a longer passage to try.

Scientists researching the aging process are increasingly investigating the role of telomeres, portions of DNA on the ends of chromosomes found in every cell. The exact relationship between telomeres and aging is unknown. Unlike the rest of the chromosome, telomeres do not contain genes, the strands of DNA that code for particular enzymes and proteins. Telomeres primarily serve a protective role in cells, playing two key roles in maintaining healthy cells. First, telomeres prevent important genetic material from being lost during cell replication, functioning as a “cap” of sorts on the end of each chromosome. Second, telomeres serve as a

biological marker that the chromosome is “complete”; without a telomere on the end of a chromosome, the body considers the chromosome defective and takes steps against it.

While the protective role of telomeres is fairly well understood, scientists are interested in another facet of telomeres. Telomeres contain between one to two thousand copies of a particular DNA sequence. Each time a cell divides, a minuscule bit of this DNA sequence is lopped off. When telomeres become too short, the cell becomes impaired, unable to divide, and prone to malfunction. Cells with critically short telomeres

eventually die, leading many researchers to compare telomeres to biological clocks or fuses, counting down to the death of a cell.

Although the role of telomeres in cellular aging and malfunction is well documented, new research is focused on searching for a link between cellular aging and aging and disease in humans. One study has found that subjects with shorter telomeres are more likely to develop cancers of the lungs and kidneys than those with longer telomeres. Furthermore, the study noted that the participants with the shortest telomeres were at a higher risk of developing heart

disease and also appeared more prone to infectious diseases. Another study posited a link between telomere length and life span. In that study, patients with shorter telomeres died about 4 or 5 years earlier than those with telomeres of greater length.

Of course, many researchers are hesitant to conclude that shorter telomeres are a causative factor from this data, particularly because telomeres are susceptible to corruption from a number of factors besides cell division. For example, scientists have noted that telomeres are especially vulnerable to the byproducts of the body's oxidation process, by which oxygen

is converted to energy. The byproducts of this process, called free radicals, can not only harm cells and DNA, but also artificially shorten telomeres.

Further research is necessary to better establish what link, if any, exists between telomeres and aging. One promising avenue to consider is whether lengthening damaged telomeres has the opposite effect on subjects, making them healthier and conferring greater longevity. And while some scientists optimistically believe that a full understanding of telomeres will eventually bestow dominion over the very aging process itself, such a scenario is

both unlikely and not technologically feasible at this juncture.

Problem or change?

What was the problem?

What caused it?

What were the effects?

Is there any solution?

The preceding passage is a long science passage with lots of technical information. In essence, however, it is about a problem. Scientists think that there is a link between

telomeres and aging, but they don't know. The cause of the problem is that there is a link between the length of a telomere and the health of cells. The effect of this problem is lots of studies showing links between telomeres and different health problems. The solution, of course, is more research. The exact relationship is still unknown.



Need More Verbal Help?

Check out *The Princeton Review's Verbal Workout for the GRE* for more Text Completion, Sentence Equivalence, and Reading Comprehension practice.

When you map the passage, paragraph by paragraph, you should come up with something like this:

Paragraph 1: What's a telomere? (Inform)

Paragraph 2: Shorter telomere = dead cell
(Inform)

Paragraph 3: Effects of shorter telomeres
(Inform)

Paragraph 4: Caution against conclusion
(Inform)

Paragraph 5: Possible effects of finding link
(Predict). Beating aging unlikely (Evaluate)

That is as much information as you need to answer Main Idea and Purpose questions, and as much as you need to get started on specific questions. If a question asks about the connection between telomeres and cell health, you know where to go. Until then, feel free to skim over the details.

SIZE UP THE QUESTIONS

Reading Comprehension questions vary in both format and what they require you to do. Let's take a look at the different types of questions you'll see on test day, and then go through strategies for tackling each type.

Question Formats

The Reading Comprehension questions on the GRE will appear in several different formats:

1. **Multiple Choice.** These are the standard, five-answer multiple-choice questions that ask you to choose a single answer.
2. **Select All That Apply.** These questions ask you to select more than one answer, similar to the way you

answered Sentence Equivalence questions.

3. **Select in Passage.** These questions either refer you to a highlighted portion of the text or ask you to click on the portion of the text that contains a certain phrase or performs a certain function.

Question Tasks

While it might seem like there are tons of different reading comprehension tasks, there are really only two major types on the GRE:

1. **“Fetch” Questions.** Some questions simply require you to go to the passage and “fetch” some information. The information you are asked to fetch might be a fact from the reading, the meaning of a word, the

author's tone, or the main idea of the passage.

2. **Reasoning Questions.** Other questions require a little more work than just returning to the passage and figuring out what the author says. Reasoning questions can ask you why an author used a particular word or sentence, what inferences you can draw from the passage, or who the author's intended audience may be. Reasoning questions may also ask critical reasoning-style "argument" questions about conclusions, premises, and assumptions.

The answer to a Reading Comprehension question has to be supported by the passage.

Each of these question tasks may show up in any of the question formats above. Let's look at some of these questions in more detail.

Fetch Questions

Fetch questions ask, in one form or another, "What does the passage say?" They are the most straightforward of reading questions, and simply require you to return to the passage and retrieve information. To answer a retrieval question, follow these steps:

1. **Read the Question.** What kind of question are you dealing with?
2. **Make the Question Back into a Question.** Often the questions aren't questions at all; they're really incomplete sentences. To find an answer, you must first have a question. By putting the question into your own words, you interact qualitatively and actively with the question text.

There is no possibility of your eyes glazing over or your brain going on autopilot (a real likelihood with a four-hour exam). To make the question into a question, simply start with a question word. Nine out of ten times *What* or *Why* will work, since most questions ask either *what* was said in the passage or *why* it was said.

3. **Find Proof.** This is the golden rule of reading comprehension. You will always be able to prove the correct answer with something in the passage. If you cannot put your finger on a specific word, phrase, or sentence that proves your answer choice, you can't pick it. To help find answers in the passage, use one or both of the following techniques:

- a. **Five Up/Five Down.** You can't trust ETS to put the

correct answer exactly where they say it will be. If they highlight a portion of the passage, start reading five lines above and read until five lines below the highlighted passage. This way, you are always looking at things *in context*.

- b. **Lead Word.** A lead word is any word in the question that will be easy to skim for in the passage. Names, numbers, dates, large technical terms all make good lead words. Of course, once you find your lead word, read five lines up and five lines down (for a vocab-in-context question, you need to read only three lines up and three lines down).

4. **Link the Info in the Passage to the Question Task.** Once you find the relevant information in the passage take a moment to make sure that it addresses the question task. Is this all the author said? Are there other details that you need to consider?
5. **Use Process of Elimination.**
 - a. **Avoid Extreme Statements.** No matter what the passage says, ETS can phrase a correct answer any way they like. They want correct answers that are difficult to argue with. That means *wishy-washy* language (often, many, usually). *Extreme* language (is, all, every, always) is too easy to prove wrong, so it almost always is incorrect.

b. **Recycled Language.** ETS knows that most test-takers spend too long reading the passage. Then, they try to answer the questions by memory. So, ETS creates a lot of wrong answers by simply recycling memorable words and phrases back into the answer choices. These answers are very appealing because you'll remember reading something like that. But, the correct answer is usually a paraphrase of the information in the passage. Just remember that the more that an answer sounds like it is word for word from the passage, the less likely it is to be right. So be suspicious of answers that

make you say “Wait! I remember reading that!”

- c. **Half Right = All Wrong.** ETS likes to write answer choices that are half right; which also means they’re half—and thus all—wrong. The first part of the answer choice will usually look good, but the second part will be incorrect. Make sure to read the entire choice carefully.
- d. **Bad Comparisons.** Be suspicious of answers that contain comparison words such as *more ... than*, *less ... than*, *greater*, *faster*, *compared to*, etc. In most cases, the items in the answer choice are mentioned in the passage but they aren’t compared in the passage. So, always be wary of

200/1507

answers that make comparisons. If you can't find the comparison in the passage, cross the answer off.

Correct answers are paraphrases of information stated in the passage.

Let's try a fetch question with the short passage you saw before.

Prior to 1735, there was no legal precedent for freedom of the press. The constitutional concept of freedom of the press traces its origins to 1735 and the libel trial of John Peter

Zenger. Zenger, born in Germany, emigrated to America in 1710 and established *The New York Weekly Journal* in 1733. The *Journal* starkly opposed the policies of New York governor William Cosby and while Zenger did not write the majority of the critical pieces, he was arrested on libel charges in 1734. In the ensuing trial, widely followed by the populace, Zenger was defended by Andrew Hamilton, a Pennsylvania lawyer who was brought in after Cosby disbarred all the New York lawyers who offered to defend Zenger. Hamilton's brilliant defense of Zenger was predicated on the argument that since Zenger's criticisms involved

verifiable facts, they could not possibly be considered libel. The judge agreed and acquitted the publisher, establishing the basic concept of freedom of the press that was to be enshrined in the United States Constitution some 57 years later.

And here's the question:

The passage states that Zenger did all of the following EXCEPT

- started his own newspaper
- opposed the governor's administration
- left his homeland to come to the United States

- sought out Andrew Hamilton to defend him
- based his criticisms on factual issues

Always go back to the passage to verify your answer. Don't answer from memory.

Here's How to Crack It

Step 1:

Read the Question. Essentially, “What did Zenger do?” This is a fetch question.

Step 2:

Make the Question Back into a Question. What did Zenger do?

Step 3:

Find Proof. “Zenger” will make a nice lead word. Find the first instance of it in the passage and read from five lines above to five lines below.

Step 4:

Link the Info in the Passage to the Question Task. In the passage, we are told that Zenger “emigrated to America,” “established *The New York Weekly Journal*,” and “opposed the policies of New York governor William Cosby.”

Step 5:

Use Process of Elimination. Use your scratch paper. Cross off answer choices (A), (B), and (C). Now we need more information, so go back to the passage and find more instances of the lead word *Zenger*. We are told that he “was defended by Andrew Hamilton” and that his “criticisms involved verifiable facts.” Choice (D) says that Zenger

“sought out Andrew Hamilton to defend him.” One might assume that since Hamilton defended him, Zenger must have sought Hamilton out to do so. Be careful, and be literal. This is how they catch smart people. If you cannot prove your answer with something stated in the passage, you can’t pick it. If the passage doesn’t say Zenger sought out Hamilton, we can’t assume it. Assumptions always get you into trouble on reading comp. If you’re not convinced, don’t get hung up; just give (D) the *maybe*, and move on. Choice (E) says that he “based his criticisms on factual issues.” We have proof for this one, so cross it off. Choice (D) is the only one left. That must be our answer.

Don’t get hung up on an answer choice in the first pass, and be incredibly literal. If the passage doesn’t say it, you can’t pick it.

Let's try another fetch question. Try the next question, again based on the passage we've already studied:

Which of the following would most effectively replace the phrase **predicated on** as it is used in the passage?

- derived from
- extirpated on
- conjectured on
- covenanted on
- relegated to

Here's How to Crack It

Treat this type of question just like a Text Completion problem. Go back to the passage and read the sentence that contains the highlighted phrase, imagining that the highlighted portion is missing: “Hamilton’s brilliant defense of Zenger was _____ the argument that since Zenger’s criticisms involved verifiable facts, they could not possibly be considered libel.” Try to come up with your own word or phrase for the blank.

The clue is that the defense had something to do with the “argument that was...” A good phrase might be *based on* or *constructed on*. Now go to the answer choices and use POE. Does *derived from* mean based on? It’s fairly close, so leave this choice. How about *extirpated*? Remember that if you’re not sure of the meaning of this word, you can’t eliminate it. Leave it for now. Answer choice (C) is not a match; *conjectured* means to guess or infer. A *covenant* is an agreement, so choice

(D) doesn't make sense either. And *relegate* means to assign, so that's out too. If you're down to choices (A) and (B), go with the one you know works. Choice (A) definitely works, so that's our answer.

Remember to keep track of new vocabulary words as you work through this book!

By the way, to *extirpate* means to tear up by the roots or destroy completely.

Select-in-Passage Questions

Think of these as regular fetch questions, but the answer choices are in the passage rather than part of the question. Most of the time you will find these questions on short

passages, but should they occur on a long passage, ETS will limit the scope of the question to a single paragraph. Follow the same steps as you would on a fetch question. Put the question into your own words. Anticipate the answer; then select it from the five or six sentences in the paragraph or passage.

Here's a practice select-in-passage question:

Prior to 1735, there was no legal precedent for freedom of the press. The constitutional concept of freedom of the press traces its origins to 1735 and the libel trial of John Peter Zenger. Zenger, born in Germany, emigrated to America in 1710 and established *The New York Weekly Journal* in 1733.

The *Journal* starkly opposed the policies of New York governor William Cosby and while Zenger did not write the majority of the critical pieces, he was arrested on libel charges in 1734. In the ensuing trial, widely followed by the populace, Zenger was defended by Andrew Hamilton, a Pennsylvania lawyer who was brought in after Cosby disbarred all the New York lawyers who offered to defend Zenger. Hamilton's brilliant defense of Zenger was predicated on the argument that since Zenger's criticisms involved verifiable facts, they could not possibly be considered libel. The judge agreed and acquitted the publisher, establishing the

basic concept of freedom of the press that was to be enshrined in the United States Constitution some 57 years later.

Select the sentence in which the author offers an opinion.

Here's How to Crack It

Select the sentence in which the author offers an opinion.

First, read the question and summarize it in your own words. The question is looking for an opinion, as opposed to a fact, and specifically, the author's opinion. Note that there are actually only seven sentences in this passage, so you have seven answer choices. One of them must contain an opinion. The other six, therefore, must be factual.

This is a great case for POE. Write A, B, C, D, E, F, and G on your scratch paper so you have something to eliminate.

Sentences 1 and 2—All dates and facts. Cross off (A) and (B).

Sentence 3—More facts. Cross off (C).

Sentence 4—More facts. Cross off (D).

Sentence 5—More facts. Cross off (E).

Sentence 6—The author describes Hamilton's defense as "brilliant." This is an opinion, not a fact. This is a possible answer. Give it a check.

Sentence 7—More facts. Cross off (G). The correct answer is sentence 6.

Now that we've cracked the fetch questions, let's move onto the next major type: reasoning questions.

Reasoning Questions

Reasoning questions ask us to do a little more work to find the proof in the passage. The best answer is still based on the passage, but we need to do a little more work to get it. Our steps for reasoning questions are pretty similar to those for fetch questions:

1. **Figure Out What the Question Wants.** Reasoning questions never ask for a simple fact from the passage. Instead, you'll need to figure out what type of information the question requires before you go back to the passage. For example, some reasoning questions may ask why an author brings up an example. Why do

authors ever bring up examples? Well, to support a point that they either just made or are about to make. So, you need to find the point that the author uses the example to support.

2. **Return to the Passage.** You'll still need to return to the passage to find the answer. In general, reasoning questions will require you to read more of the passage than simple fetch questions because often you'll need to know the context for a particular piece of information.
3. **Answer in Your Own Words If Possible.** You'll be able to complete this step for some reasoning questions, but not for others. If you can't answer in your words, go right to the answers and use POE.

POE Guidelines for Reasoning Questions

On many reasoning questions you'll have to make aggressive use of POE. Much of the guidelines you used for fetch questions still apply. However, on reasoning questions, look out for answer choices that do the following:

1. **Go Beyond the Information Given.** Often, wrong answers on these questions will go beyond the scope of the passage. In most cases, the wrong answer simply makes a claim that is stronger than the claim in the passage. In other words, be on the look out for extreme language! Choose the answer that is closest to the information in the passage.
2. **Have the Wrong Tone.** Some reasoning questions, such as strengthen and weaken questions, can use

extreme language while others, such as inference questions, generally should not. Make sure the tone of the answer choice is appropriate to the question task.

3. **Are Only Half Right.** Again, answers that are only half right are all wrong and you should eliminate them.

Here's a practice reasoning question and another familiar passage to work with:

What was it about Oscar Wilde's only novel, *The Picture of Dorian Gray*, that caused it to create such an uproar when it was published in 1891? While critics attacked the quality of Wilde's work, lambasting its

plot as “incurably silly” and chiding the writer for using prose that was “clumsy” and “boring,” these overt denunciations of the formal elements of Wilde’s work merely masked the true concerns of many nineteenth-century critics. What these critics were actually railing against was the thematic content of Wilde’s work, specifically his illustration of a lifestyle devoted to useless beauty. For many a nineteenth-century moralist, *The Picture of Dorian Gray* was nothing more than a primer for spiritual depravity. Wilde’s ultimate sin was not his clunky plot or his sometimes cloying prose; it wasn’t even his disregard for the time-honored tradition of

English propriety. It was instead his leniency toward his protagonist. Wilde propagated the disdain of critics not simply because Dorian Gray was an unabashed hedonist, but because Wilde failed to punish his subject appropriately for his hedonism. To the critics, allowing an evil character to escape his just desserts was an unforgivable sin, and it was this transgression that resulted in such opprobrium for Wilde's work. In their mind, Wilde's work was corrupting the genteel reading public by failing to show the proper consequences of immoral behavior.

The author of the passage would probably consider which one of the

following situations most analogous to the response of the critics in the highlighted sentence?

- A college professor lowers a student's grade from an A to a B because the student is chronically late to class.
- An accountant refuses to help his clients cheat on their income tax returns.
- A politician attacks the character of his opponent even though it is his opponent's positions that the politician disagrees with.
- A district attorney indicts a person on a misdemeanor charge because he lacks the evidence to convict the person on a felony charge.

- A reporter files a story despite not having been able to verify all her sources.

What sort of information do we need from the passage in order to answer this question?

Here's How to Crack It

This question wants us to figure out what the response of the critics is and then find a situation that is similar to it. First, return to the passage and read the highlighted sentence. Based on the sentence, it appears that the situation is that “the people attacked this thing for one reason, but there was really another reason they didn’t like it.”

Now you’re ready to return to the answer choices and look for the best match. The situation in the first answer choice is not the

same as what we've written; here the professor is penalizing a student for the student's poor performance in class. Eliminate it. Choice (B) doesn't match—the accountant is refusing to do something illegal. The third choice seems like a good match; the politician attacks his opponent for one reason (his character), but there was another reason (his policies) for his dislike of the candidate.

Let's check the remaining choices to make sure our answer is the best answer. In choice (D), the district attorney indicts on a lesser charge because of a lack of evidence for a more serious charge. This is somewhat similar, in that there is an overt element (the misdemeanor charge) and also a second factor which is not overt (the felony charge). However, the part of the answer choice that mentions the lack of evidence makes this choice worse than (C). It goes beyond the information presented in the passage because

the original situation in the passage doesn't mention a lack of evidence on behalf of the critics. Finally, choice (E) is not a match at all. This situation involves a reporter who puts forth something that has not been verified, which isn't the same as criticizing something for one reason when there is another, deeper reason. Thus, choice (C) is our answer.

Ready for another reasoning question? It's based on the passage we just used.

Consider each of the choices separately and select all that apply.

The author of the passage would probably agree with which of the following statements?

- Most critics of Oscar Wilde's novel objected primarily to the lifestyle of its author.
- If *The Picture of Dorian Gray* were written in the twenty-first century, the critical reaction would be less severe.
- Some critics of Wilde's *The Picture of Dorian Gray* believed that an author of a book had a moral responsibility to the book's audience.

Here's How to Crack It

To answer this question, we have to figure out which answer choice the author might agree with. How the heck are we supposed to know what the author might think? Well, all we know about what the author thinks is what's found in the passage. In many ways,

“author-agree” questions are very similar to inference questions. In both types of questions, the best answer may not be explicitly stated in the passage, but there will be sufficient evidence in the passage to support the correct answer. The key here is to take each answer choice one by one and return to the passage to look for proof for it.

On Select All That Apply questions, don't feel compelled to choose more than one answer—sometimes only one choice will be correct!

The first choice states that most critics objected to Wilde's lifestyle. Can you find any evidence of this in the passage? No. Nowhere does the passage mention his lifestyle. It says that the critics disagreed with the “thematic content,” but we can't assume that Wilde based his work on his own lifestyle (and of

course, you can't use any outside knowledge you may have of Wilde's licentious life). Remember: You have to stay inside the scope of the passage—don't go beyond the information given. Thus, choice (A) is no good.

Now look at the second choice. Is there any evidence about how the author would feel if the book were released today? Nope. Of course, you may assume that the author would agree with this choice, but again, on the GRE that isn't good enough. We need direct evidence from the passage and there is none for this choice. So, goodbye to choice (B). Let's go to the third and final answer. Return to the passage and look for the part about the book's audience. The last two lines make it clear that some critics saw Wilde's book as corrupting the public and for this they attacked it. This would support choice (C), so that's our best answer. Notice that in these multiple-choice, multiple-answer

questions, there need not be two answers—sometimes there will just be one!



FIND THE PARAPHRASE OF THE TEXT

Because the right answer to every Reading Comprehension question is literally right in front of you, ETS goes to great lengths to disguise the correct answer and to make the wrong answers more appealing. ETS does this by making the best answer a clever paraphrase of the words in the text, one that basically states the same idea but usually avoids repeating words verbatim from the text. By paraphrasing, ETS is able to create right answers that “fly under the radar”; they don’t stand out and they’re easy to dismiss in favor of the trap answers.

Paraphrasing the information in the text is ETS’s job. Your job is simpler. You just need to find the information in the passage that addresses the task of the question. Once

you've found that information, you can compare each answer choice to your proof from the passage. If the answer choice is a good paraphrase of your proof from the passage, then that will very likely turn out to be the credited response.

As always, balance looking for the right answer with being suspicious of every answer. For most reading questions, there are more wrong answers than right answers. So, read each answer choice as though it is likely to be wrong.

USE PROCESS OF ELIMINATION

As you've surely noticed by now, the answer to a Reading Comprehension question is the one that is supported by evidence from the passage. Regardless of the question type or format, that rule is immutable. Here is a recap of other guidelines to use when you're using POE:

1. **Avoid Extreme Statements.** ETS prefers wishy-washy statements to extreme ones. When in doubt, pick the answer that has a weaker tone.
2. **Half Right = All Wrong.** ETS likes to write answer choices that are half right; which also means that they're half—and thus all—wrong. The first part of the answer choice will usually look good, but the second part will be

incorrect. Make sure to read the entire choice carefully.

- 3. Recycled Language.** Some wrong answer choices just take parts of the passage and garble them. These answers usually contain information that's taken directly from the passage rather than paraphrasing it. Eliminate them!
- 4. Beyond the Information Given.** These answers go too far beyond what is written in the passage. If you can't point to a part of the passage that matches information in the answer choice, that choice is probably wrong.

ETS constructs correct answer choices that cannot be disputed. The more extreme a choice is, the less likely it is to be the answer.

Let's explore these guidelines in a little more detail.

Avoid Extreme Statements

Extreme statements are answer choices that make absolute claims. There are very few absolutes in the world, so you shouldn't expect ETS reading passages (which are all excerpted or based on actual academic papers) to contain extreme statements.

Certain words make choices extreme and, therefore, easy to dispute. Here are a few of these words.

- must
- the first
- each
- every
- all
- the best

- only
- totally
- always
- no

Extreme answers
are bad!

You shouldn't automatically eliminate a choice that contains one of these words, but you should turn your attention to it immediately and attack it vigorously. If you can find even one exception, you can eliminate that choice.

Other words make choices moderate, more mushy, and therefore hard to dispute. Here are a few of these words.

- may
- can
- some
- many

- sometimes
- often

Moderate answers
are good!

For example, consider the following two answer choices:

- There is assuredly life on other planets or moons in the solar system.
- Scientists believe that there may be life on other planets or moons in the solar system.

Without even looking at a passage, you should pick the second answer choice because it's more wishy-washy; the first choice is too strong for ETS's liking.

Half Right = All Wrong

Careful reading of the answer choices is essential on Reading Comprehension questions. Remember that your job is to find flaws in answer choices and eliminate them. Many people focus on what they like about an answer, rather than what's wrong with it. ETS loves to write answer choices that start out fine, but then say something wrong. Don't be taken in by the part of the answer you like. Use a critical eye when applying POE; don't look for reasons to keep disputed answer choices, look for reasons to eliminate them. One word can make an answer choice wrong if that word isn't supported by the passage.

If an answer choice is half wrong, it's all wrong.
Focus on flaws and on Process of Elimination.

Look at the following example for the next three example questions:

Within the atmosphere are small amounts of a number of important gases, popularly called “greenhouse gases,” because they alter the flow of life and heat-energy through the atmosphere, much as does the glass shell of a greenhouse. Their effect on incoming solar energy is minimal, but collectively they act as an insulating blanket around the planet. By absorbing and returning to the earth’s surface much of its outgoing heat, these gases trap it within the lower atmosphere. A greenhouse effect is natural and essential to a livable climate on Earth.

The passage states which of the following about the effect of greenhouse gases on the environment?

- Although their effect on incoming solar energy is minimal, the presence of artificial greenhouse gases is a danger to the planet.
- The composite effect of the gases is necessary for maintaining a climate favorable to life on Earth.

In this case, the first answer starts out great—the passage does indeed state that the gases have a minimal effect on solar energy. But look at the rest of the passage. Does the passage ever talk about “artificial” greenhouse gases? Nope, so the first answer is half right, but all wrong. The second choice, however, is entirely supported by the

passage. The second sentence states that “collectively they act...,” while the final sentence says the greenhouse effect is “essential to a livable climate on Earth.”

Recycled Language

One of ETS’s favorite tricks is to write answer choices that contain information from different parts of the passage than the one to which the question refers. If you aren’t being careful, you’ll think, “I remember something like that from the passage” and pick the wrong answer choice. This is one reason it’s so important to use lead words and line references to guide you to the right part of the passage. Never answer a question from memory.



ETS also likes to conflate different parts of a passage to create an answer that uses a lot of words from the passage, but doesn't say a whole lot. For example, use the passage from the previous section to answer the following question:

The passage suggests which of the following about “greenhouse gases”?

- They are a natural source of heat energy within the atmosphere.
- They contribute to creating a habitable environment on Earth.

The first answer choice uses a lot of words from the passage, but says a whole lot of nothing. It garbles the information in the passage, which states that greenhouse gases “alter” heat energy. They are not a source of

it. The second choice, which is the correct choice, is a nice paraphrase of the last sentence. It may not sound as “correct” as the other choice, but close examination shows it to be the better answer.

Beyond the Information Given

ETS takes its reading passages from textbooks, collections of essays, works of scholarship, and other sources of serious reading matter. However, be careful not to answer questions based on the fact that you did your undergraduate thesis on the topic, or that you once read a newspaper article about the topic at hand. The answers are in the passage; don't use outside knowledge.

Remember: All of the answers you need are on the screen.

Often, these answers will make common sense, but unfortunately you can't use that as a criterion on the GRE. Which of the following answer choices is beyond the information in the passage from before?

The author of the passage would probably agree with which of the following statements?

- Without the presence of greenhouse gases, it is unlikely that the earth would be able to support life.
- Air pollution may contribute to an increase in greenhouse gases, which will in turn lead to eventual warming of the earth.

Clearly, here the second choice is beyond the information given in the passage. It may be

true and it makes common sense, but the passage never addresses it. Thus, it cannot be the correct answer on a GRE Reading Comprehension question.

UNDERSTANDING STRUCTURE IN READING AND WRITING

While the reading passages on the GRE may not represent some of the most engaging writing you've encountered, it is important to keep in mind the author's basic goal. Non-fiction writers want their writing to be understood; if you can't follow their arguments or their progression of ideas, they've failed in their jobs as writers. When you're reading or skimming a passage on the GRE, a good grasp of the structural elements in writing will aid your understanding.

First, pay attention to the structure of each paragraph. The most important information is probably going to be found at the beginning and end of the paragraph. While reading a passage, if your eyes start to glaze over,

rest assured you're not the only one. Good authors know this and make sure to put key points where they are likely to stand out. So, focus on the beginning and end of each paragraph.

Second, look for trigger words. Writers use these words as signposts to direct your reading. When you see same direction words such as *for example*, *in addition*, *and*, or *furthermore*, you know the author is going to be supporting an earlier statement. If you already understand the point of the paragraph, feel free to skim through these lines. However, opposite direction words like *although*, *but*, *yet*, and *however*, signify an important shift. Writers use words like this to direct the reader's attention to an important change or revelation in the progression of ideas.

Finally, the conclusion of the piece offers the author one last chance to get his or her point across. Always read the last paragraph. Does the piece wrap things up nicely or is there some doubt? Does the author suggest further avenues of inquiry? The way the passage ends can help you to understand the author's main point or primary purpose in writing the passage.

Paying attention to structural clues like the ones mentioned here can help you be a more effective reader. Following these principles in your own writing wouldn't hurt either.

Reading Comprehension Drill

Answers can be found in [Part V](#).

Questions 1 through 4 are based on the following reading passage.

Called by some the “island that time forgot,” Madagascar is home to a vast array of unique, exotic creatures. One such animal is the aye-aye. First described by western science in 1782, it was initially categorized as a member of the order Rodentia. Further research then revealed that it was more closely related to the lemur, a member of the primate order. Since the aye-aye is

so different from its fellow primates, however, it was given its own family: *Daubentoniidae*. The aye-aye has been listed as an endangered species and, as a result, the government of Madagascar has designated an island off the northeastern coast of Madagascar as a protected reserve for aye-ayes and other wildlife.

Long before Western science became enthralled with this nocturnal denizen of Madagascar's jungles, the aye-aye had its own reputation with the local people. The aye-aye is perhaps best known for its large, round eyes and long, extremely thin middle finger. These adaptations are quite sensible, allowing the aye-aye to see well at night and retrieve grubs, which are one of its primary food sources, from deep within hollow branches. However, the aye-

aye's striking appearance may end up causing its extinction. The people of Madagascar believe that the aye-aye is a type of spirit animal, and that its appearance is an omen of death. Whenever one is sighted, it is immediately killed. When combined with the loss of large swaths of jungle habitat, this practice may result in the loss of a superb example of life's variety.

1 of 10

Based on the information given in the passage, the intended audience would most likely be

- visitors to a natural science museum
- professors of evolutionary science

- a third-grade science class
- students of comparative religions
- attendees at a world culture symposium

2 of 10

The author's attitude toward the aye-aye, as represented in the highlighted text, could best be described as

- admiring
- mystified
- reverent
- appalled
- lachrymose

3 of 10

Select the sentence in the first paragraph that suggests the author's claim that "this practice may result in the loss of a superb example of life's variety" is unlikely to happen.

4 of 10

Consider each of the choices separately and select all that apply.

Which of the following statements can be logically inferred from the passage?

- Taxonomic classifications are not always absolute.
- The traditional religion of Madagascar involves augury.
- There are no longer enough resources on the main island to support the aye-aye population.

Questions 5 through 6 are based on the following reading passage.

A novel that is a bestseller is often, because of its popularity, not taken seriously as literature. Critics seem to presuppose that great literature must be somehow burdensome to the reader; it must be difficult for the uninitiated to understand. It is precisely this inverted snobbery that has hindered Isabel Allende's *The House of the Spirits* from gaining the critical attention it deserves.

Published in 1982, the novel draws deeply on the author's own family history. Allende is the first cousin once removed of former Chilean president Salvador Allende, who was murdered during a right-

wing military coup in 1973. Yet rather than the to-be-expected socialist harangue, Allende subtly works her political message within the fabric of the compelling narrative she weaves. While Allende borrows a bit too freely from Gabriel García Márquez's work, she nevertheless has a powerful and original voice within the construct of magical realism.

5 of 10

The author of the passage would probably consider which of the following situations to be most analogous to the critics' viewpoint as it is described in the highlighted sentence?

- Avant-garde movies with complicated storylines are deemed cinematically superior works to Hollywood blockbusters with straightforward narratives.
- Scientific journals are thought of as providing coverage of natural events that is inferior to that provided by nature documentaries.
- Poetry is considered superior literature to prose because it is shorter, and therefore the message it conveys is more easily understood.
- Political diatribes are viewed as falling outside the accepted literary canon because they are too controversial.

- A movie version of a popular novel is considered artistically superior to the original.

6 of 10

It can be inferred from the passage that

- Allende's novel is a retelling of her family's political struggles
- Allende's novel would have received more favorable reviews if critics had believed it to be great literature
- Allende learned about magical realism from Gabriel García Márquez
- Allende's novel could have been more compelling if she

had included a stronger political message

- readers might have expected Allende's work to be more political than it actually was

Questions 7 through 8 are based on the following reading passage.

Bronson Alcott is perhaps best known not for who he was, but for whom he knew. Indeed, Alcott's connections were impressive by any standards: He was a close confidante of such luminaries as Margaret Fuller, Ralph Waldo Emerson, and Henry David Thoreau. Yet, to remember the man solely by his associations is to miss his importance to nineteenth-century American philosophy as a whole and to the Transcendental Movement in particular. Admittedly, Alcott's gift was not as a writer. His philosophical treatises have rightly been criticized by many as being ponderous, esoteric, and lacking focus.

However, Alcott was an erudite orator, and it is in the text of his orations that one begins to appreciate him as a visionary. Most notably, Alcott advocated what were at the time polemical ideas on education. He believed that good teaching should be Socratic in nature and that a student's intellectual growth was concomitant with his or her spiritual growth.

7 of 10

It can be inferred from the passage that the author would agree with all of the following statements EXCEPT

- Alcott should be remembered for his contributions to Transcendentalism

- Alcott's ideas were ahead of those of many of his contemporaries
- Alcott believed that learning should not neglect a student's spiritual education
- Alcott's ideas about education were not always accepted by his compatriots
- Alcott should not be regarded as a particularly gifted orator

8 of 10

It can be inferred that the author would agree with which of the following statements?

- Transcendentalism was an esoteric field of inquiry

promulgated by a select group of visionaries.

- Alcott's prose style is not always easily understood.
- A Socratic pedagogical style is difficult to align with spiritual teaching.
- Alcott should be chiefly appreciated for the strengths of his association.
- The text of Alcott's orations were widely accepted by his peers.

Questions 9 through 10 are based on the following reading passage.

Echinosorex gymnura, known colloquially as the moonrat or gym-nure, is one of the many fascinating creatures that inhabit the jungles of Southeast Asia. A close relative of the hedgehog, the moon rat likewise belongs to the order *Insectivora* and the family *Erinaceidae*. However, the family then splits into the sub-family *Hylomyinae*, which contains three separate genera and eight distinct species. The appearance and habitat of the moonrat are actually far more similar to those of various members of the order *Rodentia*, though its eating habits are more in line with its fellow insectivores. Ultimately, the taxonomic

classification of this animal is useful only when considered along with other information regarding the animal's ecological niche.

9 of 10

Consider each of the choices separately and select all that apply.

Which of the following scenarios demonstrates the idea put forth by the author of this passage regarding animal classification?

- While studying a population of bears, scientists rely solely on the traditional taxonomic designations to identify likely hunting grounds.
- A team of medical researchers closely monitors the actions of

the animals involved in a study and compares its findings with prevailing beliefs about those animals.

- A zookeeper designs a habitat for a new acquisition, disregards taxonomic classifications and instead focuses on observational data.

[10](#) of 10

The author's tone could best be described as

- exasperated
- didactic
- ambivalent
- morose
- laudatory

Summary

- Before answering the questions, attack the passage. Read the passages looking for the main idea, structure, and tone. Remember that looking for problems or changes is the key to finding the main idea.
- For short passages, read the entire passage. For medium passages, focus on the beginning and end. For longer passages, read the first few lines of each paragraph and the final lines of the entire passage.
- Take a moment to understand the question task. Fetch questions ask you to retrieve information from the passage. Reasoning questions ask

you to do something more than simply figure out what the author is saying.

- Return to the passage to find the answer to the question. Don't answer from memory! Go back to the text and find the answer.
- Try to come up with an answer in your own words before looking at the answer choices ETS provides. Remember to look for paraphrases of the text, not direct quotes.
- Eliminate answers that contain extreme language, go beyond the information provided, garble the meaning of the text, or otherwise have information that you can't support from the text.

Chapter 7

Critical Reasoning

While ETS considers Critical Reasoning questions to fall within the category of Reading questions, the questions are different enough to merit a separate discussion. Let's jump in!

CRITICAL REASONING

Critical-reasoning questions are composed of short reading passages, typically just one paragraph long, followed by a series of questions about the author's argument. You should expect to see anywhere from two to four critical-reasoning questions within your two GRE Verbal sections.

Here's a sample critical-reasoning passage and question:

For more than fifty years, many evolutionary biologists posited that early fish such as *Eusthenopteron* developed limbs as a result of the need to drag themselves across short distances when their watery habitats dried up during periods of drought. However, new fossil evidence

suggests that this hypothesis is incorrect. Fossilized remains of *Acanthostega*, a primitive fish, reveal that even though the animal had rudimentary limbs, it could not walk on land. *Acanthostega* lacked ankles, which means that its limbs couldn't support its weight; furthermore, its ribs were too short to prevent the organism's chest cavity from collapsing once the animal left water.

Which of the following would most strengthen the author's argument?

- The fossilized remains of the *Acanthostega* are the earliest known evidence of early fish.
- The modern descendants of *Acanthostega* are not able to drag themselves across short distances on land.

- Biologists have found that some aquatic species can successfully drag themselves across land even though these species do not possess ankles.
- Any animal with a collapsed chest cavity is not able to survive long enough to travel even a short distance across land.
- Some evolutionary biologists believe that the new fossils are not from *Acanthostega*.

The answer to this question, by the way, is (D). Not sure why? Keep reading.

What Exactly Is Critical Reasoning?

Critical reasoning is our term for a specific type of reading passage you'll encounter on the GRE. At first glance, critical-reasoning passages resemble the short Reading Comprehension passages. However, what distinguishes critical reasoning from a regular reading passage is twofold:

1. The structure of the passage
2. The types of questions ETS will ask about it

We'll show you how to identify critical-reasoning passages and the most effective way of tackling these questions as well.

BREAKING AN ARGUMENT DOWN

The key to doing well on critical-reasoning questions is understanding how ETS authors construct an argument. All arguments contain two major parts—the conclusion, or the main point of the argument, and the premise—the facts that the author gives in support of his or her conclusion. Identifying these two parts is crucial to your success on these questions. Let's start our analysis of an author's argument in a critical-reasoning passage by learning how to identify the conclusion.

Identifying the Conclusion

The conclusion is the most important part of the argument; quite simply, it is the reason the argument exists. The conclusion of an

argument is generally a statement of opinion—it's the author's belief or prediction about a situation. Let's look at the sample critical-reasoning passage again:

For more than fifty years, many evolutionary biologists posited that early fish such as *Eusthenopteron* developed limbs as a result of the need to drag themselves across short distances when their watery habitats dried up during periods of drought. However, new fossil evidence suggests that this hypothesis is incorrect. Fossilized remains of *Acanthostega*, a primitive fish, reveal that even though the animal had rudimentary limbs, it could not walk on land. *Acanthostega* lacked ankles, which means that its limbs couldn't support its weight; furthermore, its ribs were too short to prevent the organism's

chest cavity from collapsing once the animal left water.

The conclusion is the author's main point.

You can identify the conclusion of the author's argument by asking yourself this question: What opinion does this author hold? Now underline the sentence that you think is the conclusion of the argument above.

If you underlined "new fossil evidence suggests that this hypothesis is incorrect," you hit the nail on the head.

There are other ways of identifying conclusions in arguments. For example, often you can identify the conclusion by certain key words. Specifically, keep an eye out for the following:

308/1507

An argument's conclusion is often signaled by these words:

*therefore thus consequently and
so in conclusion*

You should also look for any words that indicate an opinion, such as the following:

suggest believe hope indicate argue follow

In addition, a conclusion is often a belief about what should or might happen. Look for the following:

should would must will

Remember: The conclusion is often the author's opinion about what *might* happen.

Practice: Identifying Conclusions

Underline the conclusions of the arguments in the following critical-reasoning passages. Answers can be found in [Part V](#).

1 of 5

Despite the support of the president, it is unlikely that the new defense bill will pass. A bipartisan group of 15 senators has announced that it does not support the legislation.

2 of 5

The earliest known grass fossils date from approximately 55 million years ago. Dinosaurs most likely disappeared from the earth around 60 million years ago. Based on this evidence, as well as fossilized remains of dinosaur teeth that indicate the creatures were more suited to eating ferns and palms, scientists have concluded that grass was not a significant part of the dinosaur diet.

3 of 5

Automaker *X* has lost over 2 billion dollars this year due to rising costs, declining automobile sales, and new governmental regulations. Because of the company's poor financial situation, it has asked its employees to pay more for health care and to accept a pay cut. However, the workers

at automaker *X* are threatening to go on strike. If that happens, automaker *X* will have no choice but to file for bankruptcy.

4 of 5

The rise of obesity among citizens of country *Y* has been linked to a variety of health problems. In response to this situation, the country's largest health organization has called for food manufacturers to help combat the problem. Since the leading members of the nation's food industry have agreed to provide healthier alternatives, reduce sugar and fat content, and reduce advertisements for unhealthy foods, it is likely that country *Y* will experience a decrease in obesity-related health problems.

5 of 5

Recent advances in technology have led to a new wave of “smart” appliances, including refrigerators that note when food supplies are low and place an order at the grocery store, washing machines that automatically adjust the wash cycle and temperature based upon the clothes in the machine, and doorknobs that can identify the house owner and automatically open the door. A technology expert predicts that, due to these new innovations, machines will soon outnumber humans as the number-one users of the Internet.

Some critical-reasoning questions ask you to find the conclusion of the argument. Here's an example:

Mutation breeding is a method of crop development that requires breeders to first find plants that randomly display the traits researchers are looking for, and then breed those plants with other plants displaying similar traits. In order to bring about the required mutations, researchers bombard plants with thermal neutrons, x-rays, and known carcinogenic chemicals in order to damage the plant's DNA. Today, almost all varieties of wheat grown commercially are products of mutation breeding. Ironically, when scientists discovered how to splice desirable genes directly into the plants, thus avoiding the use of harmful chemicals and radiation, critics derided the new process as potentially dangerous despite the lack of any supporting

evidence, resulting in boycotts and bans on genetically modified foods.

The argument as a whole is structured to lead to which of the following conclusions?

- Genetically modified food may have been unfairly stigmatized by its critics.
- Mutation breeding produces safer food than does genetic modification.
- Foods produced by genetic modification are healthier than foods produced by mutation breeding.
- Researchers should stop using mutation breeding in order to modify foods.

- Genetic modification of plants is more cost effective than mutation breeding of plants.

Here's How to Crack It

The conclusion, as you'll recall, is the author's opinion or belief. As you read the argument, look for indicators of the author's opinion. The first three sentences of the argument do not state opinions; the author is simply describing the method of mutation breeding. However, in the fourth sentence, the author uses the word *ironically*. This is an indicator of how the author feels. The author believes it is ironic that genetically modified foods are banned, despite "any supporting evidence" that they are dangerous, while foods created with mutation breeding, which use "harmful chemicals and radiation" account for "almost all varieties of wheat ..."

Now we just need to find an answer choice that matches this opinion. Answer choice (A) looks pretty close, so let's hang on to it. Choice (B) is the opposite of what the author argues; the argument implies that genetic modification is safer. Choice (C) is close, but the argument doesn't really discuss which foods are "healthier," just that one type is banned and the other type isn't. Choice (D) also isn't discussed. The author thinks it's ironic that genetically modified foods are banned, but never states that mutation breeding should be stopped. Finally, choice (E) doesn't work because the argument doesn't express any opinion about cost effectiveness. Thus, choice (A) is the best answer.

Finding the Premise

After you identify the conclusion of an argument, your next task is to find the argument's premise. The premise (or premises—there can be more than one) is the evidence that the author gives in support of the conclusion.

You can find the premise of an argument in two ways. First, look for statements of fact. Critical-reasoning passages are usually based on statistics, surveys, polls, or reports and all of these things are premises—in fact, these are the most common types of premises. Second, you can use a strategy we call the “Why?” Test. Once you've found the conclusion, ask yourself “Why” you should accept it; the answer or answers to that question will be the premise(s). Let's look again at the passage from the beginning of the chapter:

For more than fifty years, many evolutionary biologists posited that early fish such as *Eusthenopteron* developed limbs as a result of the need to drag themselves across short distances when their watery habitats dried up during periods of drought. However, new fossil evidence suggests that this hypothesis is incorrect. Fossilized remains of *Acanthostega*, a primitive fish, reveal that even though the animal had rudimentary limbs, it could not walk on land. *Acanthostega* lacked ankles, which means that its limbs couldn't support its weight; furthermore, its ribs were too short to prevent the organism's chest cavity from collapsing once the animal left water.

Why should you believe
this conclusion?

What facts does the author give in support of the conclusion? In this argument, the author provides the following facts: (1) *Acanthostega* lacked ankles, and (2) the creature's ribs were too short to prevent its chest cavity from collapsing. These facts are the premises of the argument.

Finally, just like conclusions, premises have certain indicator words.

An argument's premise is often signaled
by these words:

because due to since based on

Is the statement a fact,
something that you could
verify or prove? Then it's a
premise.

Practice: Finding the Premise

For each of the following arguments, identify the premise or premises that support the conclusion. Answers can be found in [Part V](#).

1 of 5

Despite the support of the president, it is unlikely that the new defense bill will pass. A bipartisan group of 15 senators has announced that it does not support the legislation.

Conclusion:

Why?

Premise:

2 of 5

The earliest known grass fossils date from approximately 55 million years ago. Dinosaurs most likely disappeared from the earth around 60 million years ago. Based on this evidence, as well as fossilized remains of dinosaur teeth that indicate the creatures were more suited to eating ferns and palms, scientists have concluded that grass was not a significant part of the dinosaur diet.

Conclusion:

Why?

Premise:

3 of 5

Automaker *X* has lost over 2 billion dollars this year due to rising costs, declining automobile sales, and new governmental regulations. Because of the company's poor financial situation, it has asked its employees to pay more for health care and to accept a pay cut. However, the workers at automaker *X* are threatening to go on strike. If that happens, automaker *X* will have no choice but to file for bankruptcy.

Conclusion:

Why?

Premise:

4 of 5

The rise of obesity among citizens of country *Y* has been linked to a variety of health problems. In response to this situation, the country's largest health organization has called for food manufacturers to help combat the problem. Since the leading members of the nation's food industry have agreed to provide healthier alternatives, reduce sugar and fat content, and reduce advertisements for unhealthy foods, it is likely that country *Y* will experience a decrease in obesity-related health problems.

Conclusion:

Why?

Premise:

5 of 5

Recent advances in technology have led to a new wave of “smart” appliances, including refrigerators that note when food supplies are low and place an order at the grocery store, washing machines that automatically adjust the wash cycle and temperature based upon the clothes in the machine, and doorknobs that can identify the house owner and automatically open the door. A technology expert predicts that, due to these new innovations, machines will soon outnumber humans as the number-one users of the Internet.

Conclusion:

Why?

Premise:

Okay. So you know how to identify the conclusion and premise(s) of an argument. Are you ready to try a critical-reasoning question? Here's one way in which ETS will test your knowledge of the parts of an argument.

What's the conclusion?
What's the premise?

A common myth is that animals can sense an impending earthquake. And while most geophysicists dispute this

assertion and claim that there is no way to predict an earthquake, a new hypothesis for predicting earthquakes is generating interest in the scientific community. This hypothesis is based on a well-known principle: **Subjecting rocks to extreme pressures causes the rocks to produce electrical currents.** Now, a leading physicist has proposed that this principle may help predict earthquakes. For example, an earthquake along the San Andreas Fault in California could produce hundreds of thousands of amperes (units of electrical current) that would disrupt the ionosphere surrounding the earth. **By monitoring the ionosphere for electrical fluctuations, scientists may be able to predict earthquakes.**

In the argument above, the two bold-faced statements play which of the following roles?

- The first statement expresses the conclusion of the argument while the second statement provides support for that conclusion.
- The first statement expresses the conclusion of the argument as a whole; the second statement provides a possible consequence of the conclusion.
- The first statement presents support for the conclusion of the argument as a whole; the second statement states the conclusion of the argument.
- The first statement expresses an intermediary conclusion of the

argument while the second statement presents a possible objection to the intermediary conclusion.

- The first statement provides support for a conclusion that the argument opposes; the second statement expresses the conclusion that the argument as a whole opposes.

Here's How to Crack It

The key to cracking this question is using the “Why?” test. Let’s try using the “Why?” test on the two boldfaced statements and see which one works best. If we make the first statement the conclusion, we’d end up with something like this:

Conclusion: Subjecting rocks to extreme pressures causes the rocks to produce electrical currents.

Why?

Premise: By monitoring the ionosphere for electrical fluctuations, scientists may be able to predict earthquakes.

Does that make sense? Nope, so let's eliminate any answers that say that the first sentence is the argument's conclusion. That allows us to eliminate choices (A), (B), and (D). Now let's see what happens if we flip the statements around:

Conclusion: By monitoring the ionosphere for electrical fluctuations, scientists may be able to predict earthquakes.

Why?

Premise: Subjecting rocks to extreme pressures causes the rocks to produce electrical currents.

That makes much more sense. Answer choice (E) states that the argument opposes the conclusion, which it doesn't, so we can eliminate that choice. Answer choice (C) is the best answer.

The “Why?” test helps to identify premises and conclusions.

Locating Assumptions

Although ETS frequently asks critical-reasoning questions about the premise or the conclusion of an argument, there are a

number of other question types that require you to work with one final part of an argument. The final part of an argument is the assumption. The assumption is never explicitly stated in the passage, which means that it can sometimes be tricky to find. Basically, the assumption is the missing link that connects the conclusion of an argument to its premise.

Let's look back at one of the arguments you've already worked on.

Conclusion: It is unlikely that the new defense bill will pass.

Why?

Premise: A bipartisan group of 15 senators has announced that it does not support the legislation.

In order for this argument to be convincing, the reader has to make an assumption that because 15 senators do not support the bill, the bill will probably not pass. If you don't assume that the opposition of 15 senators means that the bill is unlikely to pass, the argument fails. Thus, assumptions are necessary to a successful argument.

To find the assumption or assumptions in an argument, you need to look for a “gap” in the reasoning of the argument. You can often accomplish this by asking yourself the following question:

*Just because (**premise**) is true, does it really mean (**conclusion**) is true?*

For example, let's return to another of the arguments you've already tackled.

Conclusion: Country *Y* will experience a decrease in obesity-related health problems.

Why?

Premise: The leading members of the nation's food industry have agreed to provide healthier alternatives, reduce sugar and fat content, and reduce advertisements for unhealthy foods.

Now, let's ask ourselves the question: Just because it's true that the food industry has agreed to provide healthier alternatives, reduce sugar and fat content, and reduce advertisements for unhealthy foods, does it really mean that obesity-related health problems will decrease?

If you accept this argument, you must assume that the food industry's actions will lead to a decrease in obesity-related health problems. That's the missing link—or the assumption—required by the argument.

Practice: Locating Assumptions

For each of the following critical-reasoning questions, identify the conclusion and the premise. Then note what assumption is required to make the argument work. Answers can be found in [Part V](#).

1 of 4

City University recently announced the retirement of Professor Jones. Professor Jones is a leading biologist and widely published author and her presence was a major factor in many students' decisions to attend City University. The University predicts no decline in enrollment, however,

because it plans to hire two highly credentialed biology professors to replace Professor Jones.

Conclusion:

Premise: _____

Assumption:

[2](#) of 4

It is unjust to charge customers under the age of 25 more to rent a car than those over the age of 25. After all, most states allow people as young as 16 to have a driver's license and all states allow 18-year-olds the right to vote.

Conclusion:

Premise: _____

Assumption:

3 of 4

It is easy to demonstrate that extra-terrestrial life exists by simply looking at our own solar system. In our solar system, there are eight planets and at least one of them obviously has life on it. Thus, roughly 12.5% of planets in the universe should have life on them.

Conclusion:

Premise: _____

Assumption:

[4](#) of 4

State A is facing a serious budget shortfall for the upcoming year. Recent polls indicate that 58% of voters in Township B approve of a proposed 2-cent gasoline tax in order to make up the deficit. It is clear, therefore, that the leaders of State A should institute the gas tax.

Conclusion:

Premise: _____

Assumption:

CRITICAL REASONING QUESTION TYPES

Now that you've familiarized yourself with the basics of an argument, let's look at the types of argument questions you'll encounter on the GRE. Each of the following types of questions will require you to first identify the argument's premise and conclusion; after that, your task will vary depending on the type.

Reasoning Questions

You can identify Reasoning questions because they will have the following question stems:

In the argument given, the boldfaced statements play which of the following roles?

Which of the following best describes the function of the boldfaced statements in the argument above?

The argument above is structured to lead to which of the following conclusions?



**Need More Verbal
Help?**

Check out *Verbal Workout*
for the GRE for additional
verbal review from The
Princeton Review.

For Reasoning questions, you must isolate the premise and conclusion, but you don't need to find the assumption.

Assumption Questions

Assumption questions are usually phrased in the following ways:

The argument above assumes which of the following?

The argument above relies on which of the following?

The author's argument presupposes which of the following?

On assumption questions, you need to first locate the premise and conclusion. After that, look for the gap as described in the "Locating Assumptions" section above.

Strengthen Questions

Strengthen questions will ask you to make the argument stronger. You'll be asked to do this by identifying answer choices that will support the assumption. Strengthen questions are often phrased as follows:

Which one of the following, if true, would most strengthen the argument?

Which of the following, if true, would most support the author's argument?

Supporters of the argument would most likely cite which of following pieces of additional evidence?

To strengthen an argument, find the premise, the conclusion, and the

assumption. The correct answer will be a premise that supports the assumption.

Weaken Questions

As we've learned, the assumption is what makes an argument work. It follows, then, that if you attack the assumption, you will weaken the argument. You can identify Weaken questions by looking for the following:

Which one of the following, if true, would most weaken the argument?

Which one of the following, if true, casts the most doubt on the argument above?

Which one of the following, if true, would most undermine the author's argument?

On Weaken questions, once again you'll need to find the premise, conclusion, and assumption. The right answer will attack the assumption, breaking the link between the premise and the conclusion.

CRACKING CRITICAL-REASONING QUESTIONS

Ready to tackle some critical-reasoning questions? Let's go through steps you take when you run into one of these questions on the test.

The Basic Approach

When you identify a question as being a critical-reasoning question on the exam, go through the following steps:

1. **Read the Question Carefully.** Don't dive into the passage without being aware of exactly what you're dealing with—start by making sure that it really is critical reasoning and

not a plain old reading comprehension passage.

2. **Analyze the Argument.** Identify the premise, conclusion, and assumption of the argument.
3. **Know What the Answer Needs to Do.** For each type of question, you can know what characteristic the right answer needs. For example, a weaken question attacks the assumption of the argument.
4. **Use Process of Elimination.** Process of Elimination (POE) is a valuable tool. If you're not sure what the correct answer is, look for the wrong answers instead; eliminate them, and even if you still can't identify the correct answer, you have a much greater chance of guessing the correct answer.

Try going through these steps on the following question.

After examining the bodies of a dozen beached whales and finding evidence of bleeding around the animals' eyes and brains as well as lesions on their kidneys and livers, environmental groups fear that the Navy's use of sonar is causing serious harm to marine animals. A leading marine biologist reports that sonar induces whales to panic and surface too quickly, which causes nitrogen bubbles to form in their blood.

The argument above relies on which of the following assumptions?

- Marine biologists have documented that other marine

animals, including dolphins and sea turtles, have exhibited kidney and liver lesions.

- No studies have been conducted on the possible detrimental effects of sonar on marine animals.
- Whales in captivity panic only when exposed to man-made, rather than natural, sound waves.
- The presence of nitrogen bubbles in the blood has been demonstrated to cause damage to various internal organs.
- It is unlikely that the symptoms found in the beached whales could be caused by any known disease.

Here's How to Crack It

Let's apply the four-step basic approach:

1. **Read the Question Carefully.**

This is an Assumption question—we know this because it asks you to determine what the argument relies on.

2. **Analyze the Argument.** Be sure to precisely identify the conclusion and premise. You should come up with the following:

Conclusion: The Navy's use of sonar is causing serious harm to marine animals.

Why?

Premise: Surfacing too quickly causes nitrogen bubbles to form in the whale's blood.

Next, we need to locate the assumption. Remember to use the question we introduced earlier—here it would be phrased as follows:

“Just because the whales have nitrogen bubbles in their blood, does that really mean that sonar is causing them serious harm?”

- 3. Know What the Answer Needs to Do.** Assumptions connect the premise to the conclusion. So, you want an answer that has something from both the premise and the conclusion in it.
- 4. Use Process of Elimination.** Check out the grey box for some POE tips on “assumption” questions.

Eliminate answers that aren't relevant to the argument!

Now, returning to the answer choices, let's see which one is best. Answer choice (A) is wrong; this choice doesn't connect the premise to the conclusion. Even though it states that other animals have exhibited similar symptoms, we need the answer choice to connect the symptoms—in whales—to the use of sonar. Choice (B) is wrong as well. (B) brings in information that isn't part of the original argument: It's irrelevant whether or not the Navy has conducted studies on the harmful effects of sonar. Answer choice (C) doesn't help much either; the argument is not concerned with the situations under which whales panic. Answer (D) looks pretty good. It connects the nitrogen bubbles found in the premise to the serious harm mentioned in the conclusion, so hold on to this choice. Remember that you always need to check all five answers; however, answer choice (E) is no good. Like choice (B), this choice brings in information that isn't

relevant to the argument. The fact that the symptoms are unlikely to be caused by any known disease does not make the link between the sonar and the harm to the animals. Thus, choice (D) is the best answer.

POE for Assumption Questions

When you're using POE on Assumption questions, always eliminate answer choices that do the following:

1. **Give New Information.** The assumption must link the premise and the conclusion. Any answer choices that discuss information that is not part of the original argument are wrong.
2. **Have the Wrong Tone.** The tone of the answer choice should

match the tone of the argument. Arguments that have very strong conclusions require very strongly worded answer choices, and arguments that have milder tones require milder answer choices.

3. **Weaken the Argument.** The assumption is necessary to the argument. Eliminate any answer choice that would weaken or hurt the argument—unless of course you're dealing with a Weaken question!



Strengthen Questions

Here's another critical-reasoning question:

The Japan Aerospace Exploration Agency has announced plans for a new unmanned space probe. The probe, named Hayabusa, will rendezvous with an asteroid some 290 million kilometers away from Earth and attempt to land on the asteroid. After the landing, Hayabusa will release a robotic rover which will photograph the surface of the asteroid and also collect rock and dust samples. The probe will then return to Earth with the samples. Scientists believe that the mission, if successful, will provide important clues about the

composition of the early solar system.

Which of the following, if true, most strongly supports the scientists' conclusion about the Hayabusa mission?

- Once the Hayabusa probe reaches the asteroid, researchers calculate that it will have a 60% chance of successfully landing on the asteroid.
- The asteroid targeted by the Hayabusa mission is known to have been formed at the inception of the solar system.
- The Japan Aerospace Exploration Agency has yet to experience a mechanical failure with one of its unmanned space probes.

- Some astronomers believe that many asteroids originate outside the solar system and are captured by the gravitational pull of the sun and planets.
- The Hayabusa probe is the first ever to attempt a landing on an asteroid.

Remember to identify the question type first.

Here's How to Crack It

Let's again apply the four steps:

1. **Read the Question Carefully.** It's a Strengthen question; we know this because the word “strengthen” is actually used in the question!

- 2. Analyze the Argument.** Find the premise, conclusion, and assumption.

Here's what you should end up with:

Conclusion: The mission, if successful, will provide important clues about the composition of the early solar system.

Why?

Premise: Hayabusa will release a robotic rover which will photograph the surface of the asteroid and also collect rock and dust samples.

Assumption: Rock and dust samples from an asteroid will provide scientists with information about the early solar system.

- 3. Know What the Answer Needs to Do.** To strengthen an argument, look for an answer that provides evidence that the assumption of the argument is valid.

4. **Use Process of Elimination.**

Check out the grey box on this page for some POE guidelines on Strengthen questions.

Always check all five answer choices.

Looking back at the answer choices, we see that answer choice (A) is not the best answer. This answer is only half good, indicating that the probe has a better-than-even chance of landing successfully. However, it doesn't address whether the probe's mission will help scientists understand the early solar system. Eliminate this choice. Choice (B) seems to be right on the money. The answer we're looking for should support the assumption that rock and dust samples from an asteroid will provide clues about the early solar system. Choice (B) states that the asteroid in question is, in fact, from the early solar system.

Keep looking through—remember that you're looking for the best choice.

POE for Strengthen Questions

When you're using POE on Strengthen questions, always eliminate answer choices that

1. **Are Only Half Good.** Some answers will be on the right track, but they won't strengthen the argument enough. Again remember that you're looking for the best answer, not an answer that might be good enough. You shouldn't have to make any assumptions about the answer choice in order for it to strengthen the argument.

2. **Weaken the Argument.** Typically, one of the answer choices will weaken the argument. Unless your task is to weaken the argument, you can easily eliminate it.
3. **Do Nothing.** Some answer choices do nothing to the argument; they neither strengthen nor weaken it. Get rid of these; they're decoys.

On Strengthen questions, note that answer choices that offer new information are okay, provided of course that they help strengthen the argument. Also note that answers that have strong tones are often correct for Strengthen questions.

Like answer choice (A), choice (C) is half right. However, while it might be helpful to know that it's unlikely that the probe will suffer a mechanical failure, you still have to assume that the mission itself will aid scientists in their attempts to understand the early solar system. That's just too much of a leap. Answer choice (D) actually weakens the argument. If asteroids come from outside the solar system, studying dust from them probably won't help researchers understand much from the solar system. Finally, choice (E) does nothing for the argument. The fact that the probe is the first of its kind says nothing about its scientific value. It looks like choice (B) is best; choose it and move on.

Weaken Questions

Try one last critical-reasoning question:

Psychologists have just completed an extensive study of recently divorced parents in order to determine which factors contributed most to the dissolution of the marriage. The researchers found that in a great majority of the cases of failed marriages, the couples ate, on average, fewer than 10 meals per week with each other. From this data, the psychologists have determined that a failure to spend time together during meal times is a major factor leading to divorce.

Which of the following, if true, would cast the most doubt on the researchers' hypothesis?

- Many couples who have long and successful marriages eat

together fewer than ten times per week.

- Most of the couples in the study who were unable to share meals with each other worked outside of the home.
- People who lack a regular dining schedule tend to have more disorders and illnesses of the digestive system.
- Couples in the study who reported that they ate together more than ten times per week also indicated that they tended to perceive their relationships with their spouses as healthy.
- In many cases, people in unhappy marriages tend to express their displeasure by avoiding

contact with their partners when possible.

Do you recognize what type of argument this is?

Here's How to Crack It

This is a Weaken question. Once again, we'll break the argument down into its premise, conclusion, and assumption:

Conclusion: A failure to spend time together during meal times is a major factor leading to divorce.

Why?

Premise: In a great majority of the cases of failed marriages, the couples ate, on average, fewer than 10 meals per week with each other.

Assumption: A lack of time spent eating meals together causes marital problems; there is no other cause.

The assumptions are, first, that there is no other cause, and second, that the cause and effect are not reversed. Since we want to weaken this argument, we want to find an answer that attacks one of these assumptions.

Check out the grey box for POE guidelines on Weaken questions.

POE for Weaken Questions

The guidelines for Weaken questions are basically the same as those for Strengthen questions. Eliminate any answer choices that

1. **Are Half Good.** Make sure the answer attacks the assumption thoroughly.
2. **Strengthen the Argument.** Once again, one answer usually does the opposite of the question task—eliminate the odd man out.
3. **Do Nothing.** Some answer choices neither strengthen nor weaken the argument: Eliminate them.

As is the case with Strengthen questions, new information and extreme tones in Weaken questions need not be eliminated.

Looking through the answer choices, you can probably see right away that answer choice

(A) is not the correct answer. The argument is not about what successful couples do; it is only concerned with divorced couples. Move on. Choice (B) doesn't really do anything to the argument; it's unclear how this information would affect the causal link assumed in the argument. The same goes for choice (C): All this choice indicates is that there may be other problems linked to eating—it doesn't address the connection between dining and marriage success.

Choice (D) seems like it might strengthen the argument. These couples are reporting a link between eating together more and perceiving their marriages as healthy. Eliminate this choice. Choice (E) is the best answer. This answer choice shows that the researchers have reversed the cause and effect. It is not that a failure to dine together causes marital strife; rather, couples that are already

unhappy express it by not eating together. This weakens the argument, and (E) is correct.



OTHER CRITICAL-REASONING QUESTION TYPES

The GRE also contains inference and resolve/explain questions, which require you to use different approaches from those you use for Weaken and Strengthen questions. Let's go through how to crack inference and resolve/explain questions now.

Inference and resolve/explain questions do not require you to find the premise and conclusion.

Inference Questions

An inference is a conclusion that's based on a set of given facts. You can identify inference questions because they'll look a lot like the following:

If the statements above are true, which of the following must also be true?

Which of the following statements can be properly inferred from the information above?

Based on the information above, which of the following can logically be concluded?

Here's an example:



The Mayville Fire Department always fills its employment vacancies “in-house”—when a firefighter retires or leaves the force, his or her position is filled by interviewing all qualified members of the Mayville Department who are interested in the position. Only if this process fails to produce a qualified candidate does the department begin interviewing potential employees from outside the department. This year, the Mayville Fire Department has hired three new firefighters from outside the department.

If the statements above are true, which of the following must also be true?

- For the coming year, the Mayville Fire Department will

be understaffed unless it hires three additional firefighters.

- Firefighters hired from outside the Mayville Fire Department take longer to properly train for the job.
- At the time of the vacancies in the Mayville Fire Department, either there were no qualified in-house candidates or no qualified in-house candidates were interested in the open positions.
- The three firefighters who left the department had jobs for which no other members of the Mayville Fire Department were qualified to fill.
- The three new firefighters are the first new employees hired

by the Mayville Fire
Department.

On inference questions,
you don't have to find the
premise and conclusion.

Here's How to Crack It

Inference questions are often associated with critical-reasoning passages that are not structured like the clear-cut arguments we've seen thus far. Often these wacky arguments don't even have conclusions and premises; instead, they might simply resemble a set of facts.

Our strategy for approaching these types of questions, of course, begins with identifying them as inference questions. However, for Step 2, don't attempt to identify a conclusion or premise; simply read the argument. If the

argument is complex or hard to follow, don't spend too much time trying to untangle it. Most of the work on inference questions should be done when you get to the answer choices.

For inference questions, Step 3 is simple. You're just looking for an answer that is true based on the facts provided in the argument.

Check out the POE guidelines for inference questions in the grey box on the next page.

Let's start with answer choice (A). This choice says that the department will be "understaffed." Is there any part of the argument that indicates that this is true? Nope, so eliminate this choice. Answer choice (B) states that firefighters from outside the department take longer to train, but the argument says nothing at all about training. Eliminate this choice. Choice (C) states that

either there were no qualified candidates in house or there were no qualified candidates interested in the jobs. Returning to the argument, we see that the hiring policy is that a vacant “position is filled by interviewing all qualified members of the Mayville Department who are interested in the position.” If this process fails, the department goes outside the department for candidates. Thus, since Mayville hired three new fire fighters from outside the department, answer choice (C) must be true.

Can you prove your answer choice? If not, eliminate it.

POE for Inference Questions

On inference questions, eliminate answer choices that

1. **Go beyond the Information.** Stick to the facts on inference questions. Avoid answers that are overly broad or general.
2. **Could Be True.** The correct answer on an inference *must* be true. Answers that might be true or could be true are no good.
3. **Use Extreme Language.** Be suspicious of strong language. The presence of words such as *all, none, always, never, or impossible* often means that an answer choice is wrong.

The key to inference questions is using Process of Elimination: Take each answer choice and return to the argument to see if you can prove that it's true. If you can't point to the part of the

argument that supports the answer choice, the answer is wrong.

Let's go through the remaining answers. Choice (D) is tempting, but on inference questions, we need to make sure that every part of the answer choice holds up to scrutiny. This answer states that no other members of the department were qualified to take the open positions. This could be true; however, based on the facts presented, it could also be true that there were qualified members who simply weren't interested in applying for the position. Thus, choice (D) isn't the best choice—it isn't better than (C). Finally, choice (E) goes beyond the information presented. There is no way of knowing whether these new firefighters were the first

new employees. Answer choice (C) is still the best.

Resolve/Explain

Some critical-reasoning questions will present you with a paradox—a set of facts that seem to contradict each other. On these questions, your task is to find the answer choice that best explains the contradiction. You can recognize these questions because they often contain the following phrases:

Which of the following choices would best explain the situation presented above?

Which of the following, if true, would best resolve the discrepancy above?

Which of the following, if true, best reconciles the seeming paradox above?

Take a look at the following example:

Over the past 10 years, the emergence of digital file sharing technology has threatened the traditional market for compact discs. Internet users are now able to share songs from their favorite artists with little or no loss of quality in the music, acquiring the songs they desire without having to purchase the entire compact disc. Music industry leaders contend that this practice violates their copyright and causes untold financial losses. However, consumer groups report that there has been an

increase in the sales of compact discs.

Which of the following, if true, would best explain the situation above?

- Some consumers who have downloaded songs from the Internet have been sued by major record companies.
- Research indicates that persons who engage in file sharing or song downloading are usually only casual music fans.
- The music industry is developing new technology to help prevent users from downloading songs.
- Music artists tend to release more material, on average,

today than they did 10 years ago.

- Compact discs released now often include bonus features that are appealing to fans, such as interviews with the band and music videos, that are not available for download.

Here's How to Crack It

Like inference questions, resolve/explain questions require a slightly different approach. Step 1 remains the same—read the question and identify the question type. Once you've identified the question as a resolve/explain question, read the critical-reasoning passage. However, instead of looking for a premise and conclusion, for Step 2 you're going to look for two facts that are in

conflict. The basic pattern for a resolve/explain argument is as follows:

Fact I:

But

Fact II:

For the argument in the example, two facts are in conflict:

Fact I: Internet users are able to download individual songs instead of purchasing compact discs.

But

Fact II: There has been an increase in compact disc sales.

For resolve/explain questions, the correct answer shows how both facts can be true at the same time. Proceed to Step 4, use POE, and as you read each answer choice, ask yourself the following question:

How can both (Fact I) and (Fact II) be true?

Check out the POE guidelines for resolve/explain questions in the grey box.

POE for Resolve/Explain Questions

On resolve/explain questions, you should eliminate answer choices that

1. **Do Nothing.** Many wrong answers simply do nothing to the paradox.
2. **Are Only Half Right.** Some answers will deal with only half of the conflict. Make sure the answer you select addresses both facts.

- 3. Worsen the Situation.** Eliminate choices that appear to make the situation worse.

Let's use Process of Elimination on the answer choices in our example. The first answer choice doesn't resolve the conflict. It might explain why fewer users download music, but it doesn't explain why compact disc sales have increased. Eliminate choice (A). Answer choice (B) does nothing to the paradox. The fact that the people who download music are casual fans doesn't really explain anything. Like answer choice (A), choice (C) is partly correct; however, it doesn't explain the increase in sales. Also, the answer choice states that the industry is "developing" technology; it doesn't state that the technology has been implemented yet. So

this couldn't affect the current situation. Choice (D) doesn't help much either. You might assume that more material on the market means that sales could increase even with downloading, but that line of thought requires you to fill in too many missing pieces. The correct answer should do all the work. Look at answer choice (E). This choice states that compact discs feature bonus material that can't be downloaded. This could explain both the fact that people are downloading music and that compact disc sales are increasing. Since choice (E) is a more complete explanation, it's the best answer.



WON'T ALL THIS TAKE TOO MUCH TIME?

While it may seem at first like you will need a lot of time to break down the arguments and apply the strategies, you'll get faster at doing this with practice. It's better to take your time and truly understand how the questions work than to rush through the problems, only to get them wrong.

Working more slowly
increases your accuracy,
which increases your
GRE score!

Critical Reasoning Practice Set

In this practice set, follow the steps exactly as we have presented them. Answers can be found in [Part V](#).

1 of 5

In 1989 corporate tax rates in some regions of the United States fell to their lowest level in 15 years, while the rates in other regions reached new highs. In 1974 similar conditions led to a large flight of companies from regions with unfavorable corporate tax policies to regions with favorable policies. There was,

however, considerably less corporate flight in 1989.

Which of the following, if true about 1989, most plausibly accounts for the finding that there was less corporate flight in 1989 ?

- The regions with the most favorable corporate tax policies had many of the same types of corporations as did those with unfavorable tax policies, but this was not true in 1974.
- In contrast to 1974, office rental costs in the regions with the most favorable corporate tax policies were significantly higher than rental costs in other areas of the country.
- In contrast to 1974, in 1989, the areas with the most favorable

corporate tax policies reaped the most benefit from tax incentives, although the tax codes were particularly difficult to decipher.

- Tax incentives offered by foreign countries were higher in 1989 than in 1974.
- Individual tax incentives in the areas with favorable corporate tax policies were slightly lower than they were 15 years earlier in areas with favorable corporate tax policies.

2 of 5

Aramayo: Our federal government seems to function most efficiently when decision-making responsibilities are handled by only a few

individuals. Therefore, our government should consolidate its leadership and move away from a decentralized representative democracy.

Tello: But moving our government in this direction could violate our constitutional mission to provide government of, for, and by the people.

Which of the following statements describes Tello's response to Aramayo?

- Tello contradicts the reasoning used by Aramayo.
- Tello uncovers an assumption used in Aramayo's reasoning.
- Tello brings up a possible negative consequence of accepting Aramayo's argument.

- Tello reveals the circular reasoning used by Aramayo.
- Tello shows that Aramayo overgeneralizes a very special situation.

3 of 5

Business computer systems are designed to make workers more productive by automating a portion of the work that must be completed in a business process. As a result, the employee is free to perform more tasks that require human attention. Although productivity may be lost during a learning period, many businesses experience dramatic gains in productivity after installing a new computer system. While discussing the connection between productivity gains and computer systems, a well-

respected business journal recently stated that the person who serves as the Chief Information Officer is the consummate business computer system.

By comparing a Chief Information Officer to business computer systems, the journal implicitly argues that

- Chief Information Officers should always communicate the value of computer systems to their companies
- the productivity of a company can be increased through the hiring of a Chief Information Officer
- many companies have not improved their productivity with new computer systems

- Chief Information Officers are more effective than are new computer systems
- the impact of a Chief Information Officer on a company's productivity is difficult to measure

4 of 5

Whenever Joe does his laundry at the Main Street Laundromat, the loads turn out cleaner than they do when he does his laundry at the Elm Street Laundromat. Laundry done at the Main Street Laundromat is cleaner because the machines at the Main Street Laundromat use more water per load than do those at the Elm Street Laundromat.

Which of the following statements, if true, helps support the conclusion above?

- The clothes washed at the Elm Street Laundromat were, overall, less clean than those washed at the Main Street Laundromat.
- Joe uses the same detergent at both laundromats.
- The machines at the Oak Street Laundromat use twice as much water as do those at the Main Street Laundromat.
- Joe does three times as much laundry at the Main Street Laundromat as he does at the Elm Street Laundromat.
- Joe tends to do his dirtier laundry at the Elm Street Laundromat.

5 of 5

According to the United States Postal Service bureau of information, the rate of complaints concerning late delivery was 30 times higher in 1991 than in 1964. Because the United States Postal Service changed neighborhood routes from a multiple-truck delivery system to a single-truck delivery system between 1964 and 1991, the enormous increase in complaints must be a result of this systematic change.

Which of the following, if true, weakens the conclusion drawn above?

- In 1991, most late-mail complaints were reported to the appropriate United States Postal Service office, whereas in 1964 most were not.

- Even in a multiple-truck delivery system, certain letters will arrive late.
- According to the United States Postal Service bureau of information, most of the complaints concerning late delivery in 1991 were about registered mail.
- The bulk amount of mail processed by the United States Postal Service was not much larger in 1991 than it was in 1964, before the systemic change occurred.
- The change in neighborhood routes from a multiple-truck to a single-truck delivery system sometimes causes enormous increase in the price of stamps.

Summary

- Most critical-reasoning questions require you to break down an argument. The conclusion is the main point of an argument. The premise is the fact cited in support of the conclusion.
- The assumption is used to link the premise and the conclusion with each other. Without an assumption, an argument breaks down.
- To crack a critical-reasoning question, read the question first so you understand the task. Some questions require you to identify the conclusion and the premise of an argument. Others ask you to find the

assumption or to strengthen or weaken the argument.

- After reading the question, break down the argument into its premise and conclusion and, if necessary, the assumption.
- Try to predict in your own words what the correct answer needs to do in order to answer the question.

Chapter 8

Vocabulary for the GRE

Words, words, words. That's what you'll find in this chapter. The following pages contain the Hit Parade, a list of some of the most common words that appear on the GRE. There are also some handy tips on studying and learning new vocabulary words and exercises to test your progress. Be advised, though, that the words in the chapter ahead are just a starting point. As you prepare for your GRE, keep your eyes open for words you don't know and look them up!

VOCAB, VOCAB, VOCAB

As much as ETS would like to claim that the GRE doesn't rely much on vocabulary, the simple fact remains that many of the questions, answer choices, and reading passages contain some difficult vocabulary. You can't improve your score substantially without increasing your vocabulary. You might think that studying vocabulary is the most boring part of preparing for the GRE, but it's one of the most important, and it's also the one part of GRE preparation that's actually useful to you beyond the confines of the test itself. And the more words that you recognize (and know the meaning of) on the test, the easier it will be. So there's no avoiding the importance of vocabulary to your success on the GRE. Unfortunately, it is virtually impossible to fairly test someone's vocabulary on a standardized test. If you memorize 1,000

words and on test day none of those words appear, does that mean you have a bad vocabulary? Of course not—it just means that you’ve been victimized by the limitations of standardized testing.

This doesn’t mean that you should take a defeatist attitude toward learning vocabulary! Even if you have only a few weeks before your test, you can still expand your vocabulary and increase your prospects of doing better on the GRE. One thing you have working in your favor is the fact that ETS loves to do the same things over and over. The words we’ve collected for you in this chapter are the words that appear most frequently on the GRE. So let’s get started learning some new words!

Improving your vocabulary
is the single most
important thing you
can do to improve your

Verbal score.

LEARN TO LOVE THE DICTIONARY

Get used to looking up words. ETS uses words that it believes the average college-educated adult should know. These words show up in newspaper and magazine articles, in books, and in textbooks. If you see a word you don't know while studying for the GRE or elsewhere, it's probably a good GRE word. Look it up and make a flash card. Dictionaries will give you the pronunciation, while digital apps can provide quick, handy look-ups for new words. Looking up words is a habit. You may have to force yourself to do it in the beginning, but it becomes more natural over time. Many of the techniques in this book will help you on the GRE but don't have much relevance in day-to-day life, but a great vocabulary and good vocabulary habits will

add a tremendous amount of value to your graduate school career and beyond.

Flashcards From Us

You can make your own flashcards or you can buy Essential GRE Vocabulary flashcards from us!

Learning New Words

How will you remember all the new words you should learn for the test? By developing a routine for learning new words. Here are some tips:

- To learn words that you find on your own, get into the habit of reading good books, magazines, and newspapers. Start paying attention to words you come across for which you don't know the definition. You might be tempted to just skip these, as usual,

but train yourself to write them down and look them up.

- When you look up the word, say it out loud, being careful to pronounce it correctly. This will help you remember it.
- When you look up a word in the dictionary, don't assume that the first definition is the only one you need to know. The first definition may be an archaic one, or one that applies only in a particular context, so scan through all the definitions.
- Now that you've learned the dictionary's definition of a new word, restate it in your own words. You'll find it much easier to remember a word's meaning if you make it your own.

Learn new words little by little; don't try to learn a ton at once!

- Mnemonics—Use your imagination to create a mental image to fix the new word in your mind. For example, if you're trying to remember the word *voracious*, which means having an insatiable appetite for an activity or pursuit, picture an incredibly hungry boar, eating huge piles of food. The voracious boar will help you to recall the meaning of the word. The crazier the image, the better.
- Keep a vocabulary notebook, or make a file with a list of new vocabulary words and put it on your desktop. Simply having a notebook with you will remind you to be on the lookout for new words, and using it will help you to remember the ones you encounter. Writing something down also makes it easier to memorize. Jot down the word when you find it, note its pronunciation and definition (in

your own words) when you look it up, and jot down your mnemonic or mental image. You might also copy the sentence in which you originally found the word, to remind yourself of how the word looks in context.

- Do the same thing with flash cards. Write the word on one side and the pronunciation, the meaning, and perhaps a mental image on the other. Stick five or six of your flash cards in your pocket every morning and use them whenever you can. Stuck on a delayed subway train? Look at your flashcards. Standing in a long line at the bank? Look at your flashcards. Sick of engaging in small talk with boring acquaintances? Look at your flashcards. (Only kidding about that last one.)
- Use your new word every chance you get. Make it part of your life. Insert it

into your speech at every opportunity. Developing a powerful vocabulary requires lots of exercise.

- Learn word roots. Many words share similar origins. By learning these common roots, you'll be better able to work with words you've never seen before. A good dictionary should list the origin and roots of the words in it.

THE HIT PARADE

You should start your vocabulary work by studying the Hit Parade, which is a list we've compiled of some of the most frequently tested words on the GRE. We put together this list by analyzing released GREs and keeping tabs on the test to make sure that these words are still popular with ETS. At the very least, answer choices that contain Hit Parade words make very good guesses on questions for which you don't know the answer. Each word on the Hit Parade is followed by the part of speech and a brief definition for the word. Some of the words on this list may have other definitions as well, but the definitions we have given are the ones most likely to appear on the GRE.

We've broken the Hit Parade down into four groups of about 75 words each. Don't try to

learn all four groups of words at once—work with one list at a time. Write the words and their definitions down in a notebook or on flash cards. It is very important to write them down yourself, because this will help you remember them. Just glancing through the lists printed in this book won't be nearly as effective: Before doing the exercises for each group, spend some time studying and learning the words first. Then use the exercises as a way to test yourself. Answers for the matching exercises appear in [Part V](#) of this book.

Hit Parade Group 1

Abscond (verb)

to depart clandestinely; to steal off
and hide

Aberrant (adj.)

deviating from the norm (noun
form: *aberration*)

Alacrity (noun)

eager and enthusiastic willingness

Anomaly (noun)

deviation from the normal order,
form, or rule; abnormality (adj.
form: *anomalous*)

Approbation (noun)

an expression of approval or praise

Arduous (adj.)

strenuous, taxing; requiring significant effort

Assuage (verb)

to ease or lessen; to appease or pacify

Audacious (adj.)

daring and fearless; recklessly bold
(noun form: *audacity*)

Austere (adj.)

without adornment; bare; severely simple; ascetic (noun form: *austerity*)

Axiomatic (adj.)

taken as a given; possessing self-evident truth (noun form: *axiom*)

Canonical (adj.)

following or in agreement with accepted, traditional standards (noun form: *canon*)

Capricious (adj.)

inclined to change one's mind impulsively; erratic, unpredictable

Censure (verb)

to criticize severely; to officially rebuke

Chicanery (noun)

trickery or subterfuge

Connoisseur (noun)

an informed and astute judge in matters of taste; expert

Convolutd (adj.)

complex or complicated

Disabuse (verb)

to undeceive; to set right

Discordant (adj.)

conflicting; dissonant or harsh in sound

Disparate (adj.)

fundamentally distinct or dissimilar

Effrontery (noun)

extreme
presumptuousness

boldness;

Eloquent (adj.)

well-spoken, expressive, articulate
(noun form: *eloquence*)

Enervate (verb)

to weaken; to reduce in vitality

Ennui (noun)

dissatisfaction and restlessness resulting from boredom or apathy

Equivocate (verb)

to use ambiguous language with a deceptive intent (adj. form: *equivocal*)

Erudite (adj.)

very learned; scholarly (noun form: *erudition*)

Exculpate (verb)

exonerate; to clear of blame

Exigent (adj.)

urgent, pressing; requiring immediate action or attention

Extemporaneous (adj.)

improvised; done without preparation

Filibuster (noun)

intentional obstruction, esp. using prolonged speechmaking to delay legislative action

Fulminate (verb)

to loudly attack or denounce

Ingenuous (adj.)

artless; frank and candid; lacking in sophistication

Inured (adj.)

accustomed to accepting something undesirable

Irascible (adj.)

easily angered; prone to temperamental outbursts

Laud (verb)

to praise highly (adj. form:
laudatory)

Lucid (adj.)

clear; easily understood

Magnanimity (noun)

the quality of being generously noble in mind and heart, esp. in forgiving (adj. form: *magnanimous*)

Martial (adj.)

associated with war and the armed forces

Mundane (adj.)

of the world; typical of or concerned with the ordinary

Nascent (adj.)

4/8/1807
coming into being; in early developmental stages

Nebulous (adj.)

vague; cloudy; lacking clearly defined form

Neologism (noun)

a new word, expression, or usage; the creation or use of new words or senses

Noxious (adj.)

harmful, injurious

Obtuse (adj.)

lacking sharpness of intellect; not clear or precise in thought or expression

Obviate (verb)

to anticipate and make unnecessary

Onerous (adj.)

troubling; burdensome

Paeon (noun)

a song or hymn of praise and thanksgiving

Parody (noun)

a humorous imitation intended for ridicule or comic effect, esp. in literature and art

Perennial (adj.)

recurrent through the year or many years; happening repeatedly

Perfidy (noun)

intentional breach of faith; treachery (adj. form: *perfidious*)

Perfunctory (adj.)

cursory; done without care or interest

Perspicacious (adj.)

acutely perceptive; having keen discernment (noun form: *perspicacity*)

Prattle (verb)

to babble meaninglessly; to talk in an empty and idle manner

Precipitate (adj.)

acting with excessive haste or impulse

Precipitate (verb)

to cause or happen before anticipated or required

Predilection (noun)

a disposition in favor of something;
preference

Prescience (noun)

foreknowledge of events; knowing
of events prior to their occurring
(adj. form: *prescient*)

Prevaricate (verb)

to deliberately avoid the truth; to
mislead

Qualms (noun)

misgivings; reservations; causes for
hesitancy

Recant (verb)

to retract, esp. a previously held
belief

Refute (verb)

to disprove; to successfully argue against

Relegate (verb)

to forcibly assign, esp. to a lower place or position

Reticent (adj.)

quiet; reserved; reluctant to express thoughts and feelings

Solicitous (adj.)

concerned and attentive; eager

Sordid (adj.)

characterized by filth, grime, or squalor; foul

Sporadic (adj.)

occurring only occasionally, or in scattered instances

Squander (verb)

to waste by spending or using irresponsibly

Static (adj.)

not moving, active, or in motion; at rest

Stupefy (verb)

to stun, baffle, or amaze

Stymie (verb)

to block; to thwart

Synthesis (noun)

the combination of parts to make a whole (verb form: *synthesize*)

Torque (noun)

a force that causes rotation

Tortuous (adj.)

winding, twisting; excessively complicated

Truculent (adj.)

fierce and cruel; eager to fight

Veracity (noun)

truthfulness, honesty

Virulent (adj.)

extremely harmful or poisonous; bitterly hostile or antagonistic

Voracious (adj.)

having an insatiable appetite for an activity or pursuit; ravenous

Waver (verb)

to move to and fro; to sway; to be unsettled in opinion

Group 1 Exercises

Match the following words to their definitions. Answers can be found in [Part V](#).

- | | |
|---|-------------------|
| 1. Improvised; without preparation | A. Veracity |
| 2. A newly coined word or expression | B. Recant |
| 3. A song of joy and praise | C. Extemporaneous |
| 4. To praise highly | D. Stymie |
| 5. Truthfulness; honesty | E. Paeon |
| 6. Frank and candid | F. Lucid |
| 7. Associated with war and the military | G. Laud |
| 8. To retract a belief or statement | H. Onerous |
| 9. Cursory; done without care or interest | I. Tortuous |
| 10. Troubling; burdensome | J. Neologism |
| 11. To criticize; to officially rebuke | K. Martial |
| 12. Winding; twisting; complicated | L. Ingenuous |
| 13. To block; to thwart | M. Censure |
| 14. Clear; easily understood | N. Perfunctory |

Hit Parade Group 2



Hold Up and Break

Did you just tackle Hit Parade Group 1? Before you jump into Group 2, give yourself a break. Take a walk, get some air, eat a snack. Let the Group 1 words sink in before you dive into Group 2.

Abate (verb)

to lessen in intensity or degree

Accolade (noun)

an expression of praise

Adulation (noun)

excessive praise; intense adoration

Aesthetic (adj.)

dealing with, appreciative of, or responsive to art or the beautiful

Ameliorate (verb)

to make better or more tolerable

Ascetic (noun)

one who practices rigid self-denial, esp. as an act of religious devotion

Avarice (noun)

greed, esp. for wealth (adj. form: *avaricious*)

Axiom (noun)

a universally recognized principle (adj. form: *axiomatic*)

Burgeon (verb)

to grow rapidly or flourish

Bucolic (adj.)

rustic and pastoral; characteristic of rural areas and their inhabitants

Cacophony (noun)

harsh, jarring, discordant sound;
dissonance (adj. form:
cacophonous)

Canon (noun)

an established set of principles or code of laws, often religious in nature (adj. form: *canonical*)

Castigation (noun)

severe criticism or punishment
(verb form: *castigate*)

Catalyst (noun)

a substance that accelerates the rate of a chemical reaction without itself changing; a person or thing that causes change

Caustic (adj.)

burning or stinging; causing corrosion

Chary (adj.)

wary; cautious; sparing

Cogent (adj.)

appealing forcibly to the mind or reason; convincing

Complaisance (noun)

the willingness to comply with the wishes of others (adj. form: *complaisant*)

Contentious (adj.)

argumentative; quarrelsome; causing controversy or disagreement

Contrite (adj.)

regretful; penitent; seeking forgiveness (noun form: *contrition*)

Culpable (adj.)

deserving blame (noun form: *culpability*)

Dearth (noun)

smallness of quantity or number; scarcity; a lack

Demur (verb)

to question or oppose

Didactic (adj.)

intended to teach or instruct

Discretion (noun)

cautious reserve in speech; ability to make responsible decisions (adj. form: *discreet*)

Disinterested (adj.)

free of bias or self-interest; impartial

Dogmatic (adj.)

expressing a rigid opinion based on unproved or improvable principles (noun form: *dogma*)

Ebullience (noun)

the quality of lively or enthusiastic expression of thoughts and feelings (adj. form: *ebullient*)

Eclectic (adj.)

composed of elements drawn from various sources

Elegy (noun)

a mournful poem, esp. one lamenting the dead (adj. form: *elegiac*)

Emollient (adj.)/ (noun)

soothing, esp. to the skin; making less harsh; mollifying; an agent that softens or smoothes the skin

Empirical (adj.)

based on observation or experiment

Enigmatic (adj.)

mysterious; obscure; difficult to understand (noun form: *enigma*)

Ephemeral (adj.)

brief; fleeting

Esoteric (adj.)

intended for or understood by a small, specific group

Eulogy (noun)

a speech honoring the dead (verb form: *eulogize*)

Exonerate (verb)

to remove blame

Facetious (adj.)

playful; humorous

Fallacy (noun)

an invalid or incorrect notion; a mistaken belief (adj. form: *fallacious*)

Furtive (adj.)

marked by stealth; covert;
surreptitious

Gregarious (adj.)

sociable; outgoing; enjoying the
company of other people

Harangue (verb)/(noun)

to deliver a pompous speech or
tirade; a long, pompous speech

Heretical (adj.)

violating accepted dogma or con-
vention (noun form: *heresy*)

Hyperbole (noun)

an exaggerated statement, often
used as a figure of speech (adj.
form: *hyperbolic*)

Impecunious (adj.)

lacking funds; without money

Incipient (adj.)

beginning to come into being or to become apparent

Inert (adj.)

unmoving; lethargic; sluggish

Innocuous (adj.)

harmless; causing no damage

Intransigent (adj.)

refusing to compromise (noun form: *intransigence*)

Inveigle (verb)

to obtain by deception or flattery

Morose (adj.)

sad; sullen; melancholy

Odious (adj.)

evoking intense aversion or dislike

Opaque (adj.)

impenetrable by light; not reflecting light

Oscillation (noun)

the act or state of swinging back and forth with a steady, uninterrupted rhythm (verb form: *oscillate*)

Penurious (adj.)

penny-pinching; excessively thrifty; ungenerous

Pernicious (adj.)

extremely harmful in a way that is not easily seen or noticed

Peruse (verb)

to examine with great care (noun form: *perusal*)

Pious (adj.)

extremely reverent or devout; showing strong religious devotion (noun form: *piety*)

Precursor (noun)

one that precedes and indicates or announces another

Preen (verb)

to dress up; to primp; to groom oneself with elaborate care

Prodigious (adj.)

abundant in size, force, or extent; extraordinary

Prolific (adj.)

498/1807
producing large volumes or
amounts; productive

Putrefy (verb)

to rot; to decay and give off a foul
odor (adj. form: *putrid*)

Quaff (verb)

to drink deeply

Quiescence (noun)

stillness; motionlessness; quality of
being at rest (adj. form: *quiescent*)

Redoubtable (adj.)

awe-inspiring; worthy of honor

Sanction (noun)/(verb)

authoritative permission or approv-
al; a penalty intended to enforce

compliance; to give permission or authority

Satire (noun)

a literary work that ridicules or criticizes a human vice through humor or derision (adj. form: *satirical*)

Squalid (adj.)

sordid; wretched and dirty as from neglect (noun form: *squalor*)

Stoic (adj.)

indifferent to or unaffected by pleasure or pain; steadfast (noun form: *stoicism*)

Supplant (verb)

to take the place of; to supersede

Torpid (adj.)

lethargic; sluggish; dormant (noun form: *torpor*)

Ubiquitous (adj.)

existing everywhere at the same time; constantly encountered; widespread

Urbane (adj.)

sophisticated; refined; elegant (noun form: *urbanity*)

Vilify (verb)

to defame; to characterize harshly

Viscous (adj.)

thick; sticky (noun form: *viscosity*)

Group 2 Exercises

Match the following words to their definitions. Answers can be found in [Part V](#).

- | | |
|---|------------------|
| 1. Brief; fleeting | A. Pernicious |
| 2. A long, pompous speech | B. Ephemeral |
| 3. Arousing strong dislike or aversion | C. Avarice |
| 4. To free from blame or responsibility | D. Quaff |
| 5. Arousing fear or awe; worthy of honor; formidable | E. Caustic |
| 6. Unexpectedly harmful | F. Odious |
| 7. To drink deeply | G. Dearth |
| 8. Stinging; corrosive; sarcastic; biting | H. Inert |
| 9. Impressively great in size, force, or extent; enormous | I. Disinterested |
| 10. Greed; hunger for money | J. Exonerate |
| 11. Unmoving; lethargic | K. Inveigle |
| 12. Impartial; unbiased | L. Prodigious |
| 13. Lack; scarcity | M. Harangue |
| 14. To win over by deception, coaxing or flattery | N. Redoubtable |

Hit Parade Group 3

Acumen (noun)

keen, accurate judgment or insight

Adulterate (verb)

to reduce purity by combining with inferior ingredients

Amalgamate (verb)

to combine several elements into a whole (noun form: *amalgamation*)

Archaic (adj.)

outdated; associated with an earlier, perhaps more primitive, time

Aver (verb)

to state as a fact; to declare or assert

Bolster (verb)

to provide support or reinforcement

Bombastic (adj.)

pompous; grandiloquent (noun
form: *bombast*)

Diatribes (noun)

a harsh denunciation

Dissemble (verb)

to disguise or conceal; to mislead

Eccentric (adj.)

departing from norms or
conventions

Endemic (adj.)

characteristic of or often found in a
particular locality, region, or people

Evanescent (adj.)

tending to disappear like vapor;
vanishing

Exacerbate (verb)

to make worse or more severe

Fervent (adj.)

greatly emotional or zealous (noun form: *fervor*)

Fortuitous (adj.)

happening by accident or chance

Germane (adj.)

relevant to the subject at hand; appropriate in subject matter

Grandiloquence (noun)

pompous speech or expression (adj. form: *grandiloquent*)

Hackneyed (adj.)

rendered trite or commonplace by frequent usage

Halcyon (adj.)

calm and peaceful

Hedonism (noun)

devotion to pleasurable pursuits, esp. to the pleasures of the senses (a *hedonist* is someone who pursues pleasure)

Hegemony (noun)

the consistent dominance of one state or group over others

Iconoclast (noun)

one who attacks or undermines traditional conventions or institutions

Idolatrous (adj.)

given to intense or excessive devotion to something (noun form: *idolatry*)

Impassive (adj.)

revealing no emotion

Imperturbable (adj.)

marked by extreme calm, impassivity, and steadiness

Implacable (adj.)

not capable of being appeased or significantly changed

Impunity (noun)

immunity from punishment or penalty

Inchoate (adj.)

in an initial stage; not fully formed

Infelicitous (adj.)

unfortunate; inappropriate

Inspid (adj.)

lacking in qualities that interest, stimulate, or challenge

Loquacious (adj.)

extremely talkative (noun form: *loquacity*)

Luminous (adj.)

characterized by brightness and the emission of light

Malevolent (adj.)

having or showing often vicious ill will, spite, or hatred (noun form: *malevolence*)

Malleable (adj.)

capable of being shaped or formed; tractable; pliable

exhibiting a fawning attentiveness

Occlude (verb)

to obstruct or block

Opprobrium (noun)

disgrace; contempt; scorn

Pedagogy (noun)

the profession or principles of teaching, or instructing

Pedantic (adj.)

overly concerned with the trivial details of learning or education; show-offish about one's knowledge

Penury (noun)

poverty; destitution

Pervasive (adj.)

having the tendency to permeate or spread throughout

Pine (verb)

to yearn intensely; to languish; to lose vigor

Pirate (verb)

to illegally use or reproduce

Pith (noun)

the essential or central part

Pithy (adj.)

precise and brief

Placate (verb)

to appease; to calm by making concessions

Platitude (noun)

a superficial remark, esp. one offered as meaningful

Plummet (verb)

to plunge or drop straight down

Polemical (adj.)

controversial; argumentative

Prodigal (adj.)

recklessly wasteful; extravagant; profuse; lavish

Profuse (adj.)

given or coming forth abundantly; extravagant

Proliferate (verb)

to grow or increase swiftly and abundantly

Queries (noun)

questions; inquiries; doubts in the mind; reservations

Querulous (adj.)

prone to complaining or grumbling; peevish

Rancorous (adj.)

characterized by bitter, long-lasting resentment (noun form: *rancor*)

Recalcitrant (adj.)

obstinately defiant of authority; difficult to manage

Repudiate (verb)

to refuse to have anything to do with; to disown

Rescind (verb)

to invalidate; to repeal; to retract

Reverent (adj.)

marked by, feeling, or expressing a feeling of profound awe and respect
(noun form: *reverence*)

Rhetoric (noun)

the art or study of effective use of language for communication and persuasion

Salubrious (adj.)

promoting health or well-being

Solvent (adj.)

able to meet financial obligations;
able to dissolve another substance

Specious (adj.)

seeming true, but actually being fallacious; misleadingly attractive; plausible but false

Spurious (adj.)

lacking authenticity or validity; false; counterfeit

Subpoena (noun)

a court order requiring appearance and/or testimony

Succinct (adj.)

brief; concise

Superfluous (adj.)

exceeding what is sufficient or necessary

Surfeit (verb)

an overabundant supply; excess; to feed or supply to excess (noun form: a *surfeit* of supplies)

Tenacity (noun)

the quality of adherence or persistence to something valued; persistent determination (adj. form: *tenacious*)

Tenuous (adj.)

having little substance or strength; flimsy; weak

Tirade (noun)

a long and extremely critical speech; a harsh denunciation

Transient (adj.)

fleeting; passing quickly; brief

Zealous (adj.)

fervent; ardent; impassioned, devoted to a cause (a *zealot* is a zealous person)

Group 3 Exercises

Match the following words to their definitions. Answers can be found in [Part V](#).

- | | |
|--|---------------|
| 1. Brief; concise; tersely cogent | A. Hegemony |
| 2. Prone to complaining; whining | B. Aver |
| 3. Fawning; ingratiating | C. Insipid |
| 4. Marked by bitter, deep-seated resentment | D. Pithy |
| 5. Controversial; argumentative | E. Placate |
| 6. Dominance of one state or group over others | F. Prodigal |
| 7. Uninteresting; tasteless; flat; dull | G. Querulous |
| 8. Thin; flimsy; of little substance | H. Surfeit |
| 9. Excess; overindulgence | I. Rancorous |
| 10. Wasteful; recklessly extravagant | J. Bombastic |
| 11. To appease; to pacify with concessions | K. Obsequious |
| 12. To assert; to declare; to allege; to state as fact | L. Evanescent |
| 13. Pompous; grandiloquent | M. Polemical |
| 14. Tending to vanish like vapor | N. Tenuous |

Hit Parade Group 4



What's Your Strategy?

Do you find flashcards helpful? Or do you prefer word lists? Or Smart Phone apps? Figure out the strategy that works best for you when it comes to learning vocabulary and stick to it!

Acerbic (adj.)

having a sour or bitter taste or character; sharp; biting

Aggrandize (verb)

to increase in intensity, power, influence, or prestige

Alchemy (noun)

a medieval science aimed at the transmutation of metals, esp. base metals into gold (an *alchemist* is one who practices alchemy)

Amenable (adj.)

agreeable; responsive to suggestion

Anachronism (noun)

something or someone out of place in terms of historical or chronological context

Astringent (adj.)

having a tightening effect on living tissue; harsh; severe; something with a tightening effect on tissue

Contiguous (adj.)

sharing a border; touching;
adjacent

Convention (noun)

a generally agreed-upon practice or
attitude

Credulous (adj.)

tending to believe too readily; gull-
ible (noun form: *credulity*)

Cynicism (noun)

an attitude or quality of belief that
all people are motivated by selfish-
ness (adj. form: *cynical*)

Decorum (noun)

polite or appropriate conduct or be-
havior (adj. form: *decorous*)

Derision (noun)

scorn, ridicule, contemptuous treatment (adj. form: *derisive*; verb form: *deride*)

Desiccate (verb)

to dry out or dehydrate; to make dry or dull

Dilettante (noun)

one with an amateurish or superficial interest in the arts or a branch of knowledge

Disparage (verb)

to slight or belittle

Divulge (verb)

to disclose something secret

Fawn (verb)

to flatter or praise excessively

Flout (verb)

to show contempt for, as in a rule or convention

Garrulous (adj.)

pointlessly talkative; talking too much

Glib (adj.)

marked by ease or informality; nonchalant; lacking in depth; superficial

Hubris (noun)

overbearing presumption or pride; arrogance

Imminent (adj.)

about to happen; impending

Immutable (adj.)

not capable of change

Impetuous (adj.)

hastily or rashly energetic; impulsive and vehement

Indifferent (adj.)

having no interest or concern; showing no bias or prejudice

Inimical (adj.)

damaging; harmful; injurious

Intractable (adj.)

not easily managed or directed; stubborn; obstinate

Intrepid (adj.)

steadfast and courageous

Laconic (adj.)

using few words; terse

Maverick (noun)

an independent individual who does not go along with a group or party

Mercurial (adj.)

characterized by rapid and unpredictable change in mood

Mollify (verb)

to calm or soothe; to reduce in emotional intensity

Neophyte (noun)

a recent convert; a beginner; novice

Obfuscate (verb)

to deliberately obscure; to make confusing

Obstinate (adj.)

stubborn; hard-headed;
uncompromising

Ostentatious (adj.)

characterized by or given to pretentious display; showy

Pervade (verb)

to permeate throughout (adj. form: *pervasive*)

Phlegmatic (adj.)

calm; sluggish; unemotional

Plethora (noun)

an overabundance; a surplus

Pragmatic (adj.)

practical rather than idealistic

Presumptuous (adj.)

overstepping due bounds (as of propriety or courtesy); taking liberties

Pristine (adj.)

pure; uncorrupted; clean

Probity (noun)

adherence to highest principles; complete and confirmed integrity; uprightness

Proclivity (noun)

a natural predisposition or inclination

Profligate (adj.)

excessively wasteful; recklessly extravagant (noun form: *profligacy*)

Propensity (noun)

a natural inclination or tendency; penchant

Prosaic (adj.)

dull; lacking in spirit or imagination

Pungent (adj.)

characterized by a strong, sharp smell or taste

Quixotic (adj.)

foolishly impractical; marked by lofty romantic ideals

Quotidian (adj.)

occurring or recurring daily; commonplace

Rarefy (verb)

to make or become thin, less dense;
to refine

Recondite (adj.)

hidden; concealed; difficult to understand; obscure

Refulgent (adj.)

radiant; shiny; brilliant

Renegé (verb)

to fail to honor a commitment; to go back on a promise

Sedulous (adj.)

diligent; persistent; hard-working

Shard (noun)

a piece of broken pottery or glass

Soporific (adj.)

causing drowsiness; tending to induce sleep

Sparse (adj.)

thin; not dense; arranged at widely spaced intervals

Spendthrift (noun)

one who spends money wastefully

Subtle (adj.)

not obvious; elusive; difficult to discern

Tacit (adj.)

implied; not explicitly stated

Terse (adj.)

brief and concise in wording

Tout (verb)

to publicly praise or promote

Trenchant (adj.)

sharply perceptive; keen;
penetrating

Unfeigned (adj.)

genuine; not false or hypocritical

Untenable (adj.)

indefensible; not viable;
uninhabitable

Vacillate (verb)

to waver indecisively between one
course of action or opinion and
another

Variegated (adj.)

multicolored; characterized by a variety of patches of different color

Vexation (noun)

annoyance; irritation (verb form: *vex*)

Vigilant (adj.)

alertly watchful (noun form: *vigilance*)

Vituperate (verb)

to use harsh condemnatory language; to abuse or censure severely or abusively; to berate

Volatile (adj.)

readily changing to a vapor; changeable; fickle; explosive (noun form: *volatility*)

Group 4 Exercises

Match the following words to their definitions. Answers can be found in [Part V](#).

- | | |
|--|----------------|
| 1. Acid or biting; bitter in taste or tone | A. Anachronism |
| 2. Sleep-inducing; causing drowsiness | B. Contiguous |
| 3. A surplus; an overabundance | C. Dilettante |
| 4. One with superficial interest in a subject | D. Intractable |
| 5. Arrogance; overbearing pride | E. Prosaic |
| 6. Sharing a border; touching; adjacent | F. Quixotic |
| 7. Talking too much; rambling | G. Recondite |
| 8. Something out of place in history or chronology | H. Vituperate |
| 9. Difficult to understand; obscure; hidden | I. Acerbic |
| 10. Dull; unimaginative; ordinary | J. Garrulous |
| 11. Unemotional; calm | K. Hubris |
| 12. Stubborn; obstinate; difficult to manage or govern | L. Soporific |
| 13. Condemn with harsh, abusive words; berate | M. Phlegmatic |
| 14. Foolishly impractical; marked by lofty ideals | N. Plethora |

BEYOND THE HIT PARADE

So you've finished the Hit Parade and you're now the master of many more words than you were before. What to do next? Why, go *beyond the Hit Parade* of course! The Hit Parade was just the beginning. To maximize your score on the GRE you must be relentless in increasing your vocabulary. Don't let up. Keep learning words until the day you sit down for the exam. The following lists of extra words don't have exercises, so just keep working with your notebook or flash cards and get your friends to quiz you. You are a vocabulary machine!

Beyond the Hit Parade **Group 1**

The following list contains some of those simple-sounding words with less common

secondary meanings that ETS likes to test on the GRE.

Alloy (verb)

to commingle; to debase by mixing with something inferior; *unalloyed* means pure

Appropriate (verb)

to take for one's own use; to confiscate

Arrest, arresting (verb)/(adj.)

to suspend; to engage; holding one's attention: as in arrested adolescence, an arresting portrait

August (adj.)

majestic, venerable

Bent (noun)

leaning, inclination, proclivity,
tendency

Broach (verb)

to bring up; to announce; to begin
to talk about

Brook (verb)

to tolerate; to endure; to
countenance

Cardinal (adj.)

major, as in cardinal sin

Chauvinist (noun)

a blindly devoted patriot

Color (verb)

to change as if by dyeing, i.e., to dis-
tort, gloss, or affect (usually the
first)

Consequential (adj.)

pompous, self-important (primary definitions are: logically following; important)

Damp (verb)

to diminish the intensity or check the vibration of a sound

Die (noun)

a tool used for shaping, as in a tool-and-die shop

Essay (verb)

to test or try; to attempt; to experiment

Exact (verb)

to demand; to call for; to require; to take

Fell (verb)

to cause to fall by striking

Fell (adj.)

inhumanly cruel

Flag (verb)

to sag or droop; to become spiritless; to decline

Flip (adj.)

sarcastic, impertinent, as in flip-pant: a flip remark

Ford (verb)

to wade across the shallow part of a river or stream

Grouse (verb)

to complain or grumble

Guy (noun)

a rope, cord, or cable attached to something as a brace or guide; to steady or reinforce using a guy: Think *guide*. (verb form: *guyed*, *guying*)

Intimate (verb)

to imply, suggest, or insinuate

List (verb)

to tilt or lean to one side

Lumber (verb)

to move heavily and clumsily

Meet (adj.)

fitting, proper

Milk (verb)

to exploit; to squeeze every last ounce of

Mince (verb)

to pronounce or speak affectedly; to euphemize, to speak too carefully. Also, to take tiny steps; to tiptoe

Nice (adj.)

exacting, fastidious, extremely precise

Occult (adj.)

hidden, concealed, beyond comprehension

Pedestrian (adj.)

commonplace, trite, unremarkable, quotidian

Pied (adj.)

multicolored, usually in blotches

Pine (verb)

to lose vigor (as through grief); to yearn

Plastic (adj.)

moldable, pliable, not rigid

Pluck (noun)

courage, spunk, fortitude

Prize (verb)

to pry, to press or force with a lever;
something taken by force, spoils

Rail (verb)

to complain about bitterly

Rent (verb)

torn (past tense of *rend*); an opening or tear caused by such

Quail (verb)

to lose courage; to turn frightened

Qualify (verb)

to limit

Sap (verb)

to enervate or weaken the vitality of

Sap (noun)

a fool or nitwit

Scurvy (adj.)

contemptible, despicable

Singular (adj.)

exceptional, unusual, odd

Stand (noun)

a group of trees

Steep (verb)

to saturate or completely soak, as in
to let a tea bag steep

Strut (noun)

the supporting structural cross-part
of a wing

Table (verb)

to remove (as a parliamentary motion)
from consideration

Tender (verb)

to proffer or offer

Waffle (verb)

to equivocate; to change one's
position

Wag (noun)

wit, joker

Beyond the Hit Parade Group 2

Abjure (verb)

to renounce or reject solemnly; to recant; to avoid

Adumbrate (verb)

to foreshadow vaguely or intimate; to suggest or outline sketchily; to obscure or overshadow

Anathema (noun)

a solemn or ecclesiastical (religious) curse; accursed or thoroughly loathed person or thing

Anodyne (adj.)/(noun)

soothing; something that assuages or allays pain or comforts

Apogee (noun)

farthest or highest point; culmination; zenith

Apostate (noun)

one who abandons long-held religious or political convictions

Apotheosis (noun)

deification; glorification to godliness; an exalted example; a model of excellence or perfection

Asperity (noun)

severity, rigor; roughness, harshness; acrimony, irritability

Asseverate (verb)

to aver, allege, or assert

Assiduous (adj.)

diligent, hard-working, sedulous

Augury (noun)

omen, portent

Bellicose (adj.)

belligerent, pugnacious, warlike

Calumniate (verb)

to slander, to make a false accusation; *calumny* means slander, aspersion

Captious (adj.)

disposed to point out trivial faults; calculated to confuse or entrap in argument

Cavil (verb)

to find fault without good reason

Celerity (noun)

speed, alacrity; think *accelerate*

Chimera (noun)

an illusion; originally, an imaginary fire-breathing she-monster

Contumacious (adj.)

insubordinate, rebellious; *contumely* means insult, scorn, aspersion

Debacle (noun)

rout, fiasco, complete failure

Denouement (noun)

an outcome or solution; the unraveling of a plot

Descry (verb)

to discriminate or discern

Desuetude (noun)

disuse

Desultory (adj.)

random; aimless; marked by a lack of plan or purpose

Diaphanous (adj.)

transparent, gauzy

Diffident (adj.)

reserved, shy, unassuming; lacking in self-confidence

Dirge (noun)

a song of grief or lamentation

Encomium (noun)

glowing and enthusiastic praise;
panegyric, tribute, eulogy

Eschew (verb)

to shun or avoid

Excoriate (verb)

to censure scathingly, to upbraid

Execrate (verb)

to denounce, to feel loathing for, to
curse, to declare to be evil

Exegesis (noun)

critical examination, explication

Expiate (verb)

to atone or make amends for

Extirpate (verb)

to destroy, to exterminate, to cut out, to excise

Fatuous (adj.)

silly, inanely foolish

Fractious (adj.)

quarrelsome, rebellious, unruly, refractory, irritable

Gainsay (verb)

to deny, to dispute, to contradict, to oppose

Heterodox (adj.)

unorthodox, heretical, iconoclastic

Imbroglia (noun)

difficult or embarrassing situation

Indefatigable (adj.)

not easily exhaustible; tireless,
dogged

Ineluctable (adj.)

certain, inevitable

Inimitable (adj.)

one of a kind, peerless

Insouciant (adj.)

unconcerned, carefree, heedless

Inveterate (adj.)

deep rooted, ingrained, habitual

Jejune (adj.)

vapid, uninteresting, nugatory;
childish, immature, puerile

Lubricious (adj.)

lewd, wanton, greasy, slippery

Mendicant (noun)

a beggar, suppliant

Meretricious (adj.)

cheap, gaudy, tawdry, flashy, showy; attracting by false show

Minatory (adj.)

menacing, threatening (reminds you of the Minotaur, a threatening creature indeed)

Nadir (noun)

low point, perigee

Nonplussed (adj.)

baffled, bewildered, at a loss for what to do or think

Obstreperous (adj.)

noisily and stubbornly defiant, aggressively boisterous

Ossified (adj.)

tending to become more rigid, conventional, sterile, and reactionary with age; literally, turned into bone

Palliate (verb)

to make something seem less serious, to gloss over, to make less severe or intense

Panegyric (noun)

formal praise, eulogy, encomium; *panegyrical* means expressing elaborate praise

Parsimonious (adj.)

cheap, miserly

Pellucid (adj.)

transparent, easy to understand,
limpid

Peroration (noun)

the concluding part of a speech;
flowery, rhetorical speech

Plangent (adj.)

pounding, thundering, resounding

Prolix (adj.)

long-winded, verbose; *prolixity*
means verbosity

Propitiate (verb)

to appease; to conciliate; *propitious*
means auspicious, favorable

Puerile (adj.)

childish, immature, jejune,
nugatory

Puissance (noun)

power, strength; *puissant* means
powerful, strong

Pusillanimous (adj.)

cowardly, craven

Remonstrate (verb)

to protest, to object

Sagacious (adj.)

having sound judgment; perceptive,
wise; like a sage

Salacious (adj.)

lustful, lascivious, bawdy

Salutary (adj.)

remedial, wholesome, causing
improvement

Sanguine (adj.)

cheerful, confident, optimistic

Saturnine (adj.)

gloomy, dark, sullen, morose

Sententious (adj.)

aphoristic or moralistic; epigrammatic; tending to moralize excessively

Stentorian (adj.)

extremely loud and powerful

Stygian (adj.)

gloomy, dark

Sycophant (noun)

toady, servile, self-seeking flatterer;
parasite

Tendentious (adj.)

biased; showing marked tendencies

Timorous (adj.)

timid, fearful, diffident

Tyro (noun)

novice, greenhorn, rank amateur

Vitiate (verb)

to corrupt, to debase, to spoil, to
make ineffective

Voluble (adj.)

fluent, verbal, having easy use of
spoken language

Part III

How to Crack the Math Section

[9 The Geography of the Math
Section](#)

[10 Numbers and Equations](#)

[11 Real World Math](#)

[12 Geometry](#)

[13 Math Et Cetera](#)

Chapter 9

The Geography of the Math Section

This chapter contains an overview of the content and structure you'll see on the Math sections of the GRE. It provides valuable information on pacing strategies and the various question formats you'll encounter on the GRE. It also goes over how to use basic test-taking techniques such as Process of Elimination and Ballparking as they relate to math questions. After finishing this chapter, you'll have a good idea of what the Math section of the GRE looks like and some basic approaches to help you navigate it.

WHAT'S IN THE MATH SECTION

The GRE Math section primarily tests math concepts you learned in seventh through tenth grades, including arithmetic, algebra, and geometry. ETS alleges that the Math sections test the reasoning skills that you'll use in graduate school, but what the Math section primarily tests is your comfort level with some basic math topics and your ability to take a test with strange-looking questions under timed conditions.

Junior High School?

The Math section of the GRE mostly tests how much you remember from the math courses you took in seventh,

eighth, ninth, and tenth grades. But here's some good news: GRE math is easier than SAT math. Why? Because many people study little or no math in college. If the GRE tested college-level math, everyone but math majors would bomb the test.

If you're willing to do a little work, this is good news for you. By brushing up on the modest amount of math you need to know for the test, you can significantly increase your GRE Math score. All you have to do is shake off the dust.

The Math section of the exam consists of two 35-minute sections, each of which will consist of 20 questions. The first 7 or 8 questions of each section will be *quantitative comparisons* (quant comp, for short). The

remainder will consist of multiple-choice or numeric-entry questions.

Predictable Triggers

The beauty of a standardized test is that it is, well, standardized. Standardized means predictable. We know exactly what ETS is going to test and how they're going to test it. The math side of the test consists of a series of utterly predictable triggers, to which we have designed a series of highly scripted responses. ETS wants you to see each problem as a new challenge to solve. What you will find, however, is that there are only about 20 math concepts that are being tested. All of the questions you will see are just different ways of asking about these different concepts. Most of these concepts you already know. Once you recognize what's being tested, even the trickiest questions become familiar and easy to solve.

It's Really a Reading Test

In constructing the Math section, ETS is limited to the math that nearly everyone has studied: arithmetic, basic algebra, basic geometry, and elementary statistics. There's no calculus (or even precalculus), no trigonometry, and no major-league algebra or geometry. Because of these limitations, ETS has to resort to traps in order to create hard problems. Even the most commonly missed GRE math problems are typically based on relatively simple principles. What makes the problems difficult is that these simple principles are disguised.



Head to your Premium
Portal to watch topnotch
Princeton Review

instructors talk about the GRE Math section and walk you through sample problems.

Many test takers have no problem doing the actual calculations involved in the math questions on the GRE; in fact, you'll even be allowed to use a calculator (more on that soon). However, on this test your ability to carefully read the problems and figure out how to set them up is more important than your ability to make calculations.

As you work through this section, don't worry about how quickly you're doing the problems. Instead, take the time to really understand what the questions are asking; pay close attention to the wording of the problems. Most math errors are the result of careless mistakes caused by not reading the problem carefully enough!

Read and Copy Carefully

You can do all the calculations right and still get a question wrong. How? What if you solve for x but the question asked for the value of $x + 4$? Ugh. Always reread the question before you choose an answer. Take your time and don't be careless. The problem will stay on the screen as long as you want it to, so reread the question and double-check your work before answering it.

Or how about this? The radius of the circle is 5, but when you copied the picture onto your scratch paper, you accidentally made it 6. Ugh! If you make a mistake copying down information from the screen, you'll get the question wrong no matter how perfect your calculations are. You have to be extra careful when copying down information.

THE CALCULATOR

As we mentioned before, on the GRE you'll be given an on-screen calculator. The calculator program on the GRE is a rudimentary one that gives you the five basic operations: addition, subtraction, multiplication, division, and square root, plus a decimal function and a positive/negative feature. It also follows the order of operations, or PEMDAS (more on this topic in [Chapter 10](#)). The calculator also has the ability to transfer the answer you've calculated directly into the answer box for certain questions. The on-screen calculator can be a huge advantage—if it's used correctly!

As you might have realized by this point, ETS is not exactly looking out for your best interests. Giving you a calculator might seem like an altruistic act, but rest assured that

ETS knows that there are certain ways in which calculator use can be exploited. Keep in mind the following:

Step 1

1. **Calculators Can't Think.** Calculators are good for one thing and one thing only: calculation. You still have to figure out how to set up the problem correctly. If you're not sure what to calculate, then a calculator isn't helpful. For example, if you do a percent calculation on your calculator and then hit "Transfer Display," you will have to remember to move the decimal point accordingly, depending on whether the question asks for a percent or a decimal.

Step 2

2. **The Calculator as a Liability.**

ETS will give you questions that you can solve with a calculator, but the calculator can actually be a liability. You will be tempted to use it. For example, students who are uncomfortable adding, subtracting, multiplying, or dividing fractions may be tempted to convert all fractions to decimals using the calculator. Don't do it. You are better off mastering fractions than avoiding them. Working with exponents and square roots is another way in which the calculator will be tempting but may yield really big and awkward numbers or long decimals. You are much better off learning the rules of manipulating exponents and square roots. Most of these problems

will be faster and cleaner to solve with rules than with a calculator. The questions may also use numbers that are too big for the calculator. Time spent trying to get an answer out of a calculator for problems involving really big numbers will be time wasted. Find another way around.

Step 3

- 3. A Calculator Won't Make You Faster.** Having a calculator should make you more accurate, but not necessarily faster. You still need to take time to read each problem carefully and set it up. Don't expect to blast through problems just because you have a calculator.

Step 4

- 4. The Calculator Is No Excuse for Not Using Scratch Paper.** Scratch paper is where good technique happens. Working problems by hand on scratch paper will help to avoid careless errors or skipped steps. Just because you can do multiple functions in a row on your calculator does not mean that you should be solving problems on your calculator. Use the calculator to do simple calculations that would otherwise take you time to solve. Make sure you are still writing steps out on your scratch paper, labeling results, and using set-ups. Accuracy is more important than speed!

Of course, you should not fear the calculator; by all means, use it and be grateful for it.

Having a calculator should help you eliminate all those careless math mistakes.

GEOGRAPHY OF A MATH SECTION

Math sections contain 20 questions each. Test takers are allowed 35 minutes per section. The first 7 or 8 questions of each math section are quantitative comparisons, while the remainder are a mixed bag of problem solving, all that apply, numeric entry, and charts and graphs. Each section covers a mixture of algebra, arithmetic, quantitative reasoning, geometry, and real-world math.

QUESTION FORMATS

Much like the Verbal section, the Math section on the GRE contains a variety of different question formats. Let's go through each question format and discuss how to crack it.

Standard Multiple Choice

These questions are the basic five-answer multiple-choice questions. These are great candidates for POE (Process of Elimination) strategies we will discuss later in this chapter.

Multiple Choice, Multiple Answer

These questions appear similar to the standard multiple-choice questions;

however, on these you will have the opportunity to pick more than one answer. There can be anywhere from three to eight answer choices. Here's an example of what these will look like:

If $\frac{1}{12} < x < \frac{1}{6}$, then which of the

following could be the value of x ?

Indicate all such values.

$\frac{2}{9}$

$\frac{1}{5}$

$\frac{2}{15}$

$\frac{1}{10}$

$$\square \frac{2}{25}$$

Your approach on these questions won't be radically different from the approach you use on standard multiple-choice questions. But obviously, you'll have to consider all of the answers—make sure you read each question carefully and remember that more than one answer can be correct. For example, for this question, you'd click on choices (C) and (D). You must select *every* correct choice to get credit for the problem.

Quantitative Comparison Questions

Quantitative comparison questions, hereafter affectionately known as “quant comp” questions, ask you to compare Quantity A to Quantity B. These questions have four answer choices instead of five, and all quant

comp answer choices are the same. Here they are:

- Quantity A is greater.
- Quantity B is greater.
- The two quantities are equal.
- The relationship cannot be determined from the information given.

Your job is to compare the two quantities and choose one of these answers.

Quant comp problems test the same basic arithmetic, algebra, and geometry concepts as do the other GRE math problems. So, to solve these problems, you'll apply the same techniques you use on the other GRE math questions. But quant comps also have a few special rules you need to remember.

There Is No "E"

Because there are only four choices on quant comp questions, after you use POE to eliminate all of the answer choices you can, your odds of guessing correctly are even better. Think about it this way: Eliminating even one answer on a quant comp question will give you a one-in-three chance of guessing correctly.

If a Quant Comp Question Contains Only Numbers, the Answer Can't Be (D)

Any quant comp problem that contains only numbers and no variables must have a single solution. Therefore, on these problems, you can eliminate choice (D) immediately

because the larger quantity can be determined. For example, if you're asked to compare $\frac{3}{2}$ and $\frac{3}{4}$, you can determine which fraction is larger, so the answer cannot be (D).

Compare, Don't Calculate

You don't always have to calculate the exact value of each quantity before you compare them. After all, your mission is simply to compare the two quantities. It's often helpful to treat the two quantities as though they were two sides of an equation. Anything you can do to both sides of an equation, you can also do to both quantities. You can add the same number to both sides, you can multiply both sides by the same positive number, and you can simplify a single side by multiplying it by one.

Do only as much work
as you need to.

If you can simplify the terms of a quant comp, you should always do so.

Here's a quick example:

Quantity A

$$\frac{1}{16} + \frac{1}{7} + \frac{1}{4}$$

Quantity B

$$\frac{1}{4} + \frac{1}{16} + \frac{1}{6}$$

- Quantity A is greater.
- Quantity B is greater.
- The two quantities are equal.
- The relationship cannot be determined from the information given.

Here's How to Crack It

Don't do any calculating! Remember: Do only as much work as you need to in order to answer the question! The first thing you should do is eliminate (D). After all, there are only numbers here. After that, get rid of numbers that are common to both columns (think of this as simplifying). Both columns contain a $\frac{1}{16}$ and a $\frac{1}{4}$, so because we're talking about addition, they can't make a difference to the outcome. With them gone, you're merely comparing the $\frac{1}{7}$ in column A to the $\frac{1}{6}$ in column B. Now we can eliminate (C) as

well—after all, there is no way that $\frac{1}{7}$ is equal to $\frac{1}{6}$. So, we're down to two choices, (A) and (B). If you don't remember how to compare fractions, don't worry—it's covered in [Chapter 11](#) (Real World Math). The answer to this question is (B).

Okay, let's talk about another wacky question type you'll see in the Math section.

Numeric Entry

Some questions on the GRE won't even have answer choices, and you'll have to generate your own answer. Here's an example:

Each month, Renaldo earns a commission of 10.5% of his total sales for the month, plus a salary of \$2,500. If Renaldo earns \$3,025 in a certain month, what were his total sales?

\$

Click on the answer box and type in a number.

Backspace to erase.

Here's How to Crack It

On this type of question, POE is not going to help you! That means if you're not sure how to do one of these questions, you should immediately move on. Leave it blank and come

back to it in your second pass through the test.

If Renaldo earned \$3025, then his earnings from the commission on his sales are \$3025 - \$2500 = \$525. So, \$525 is 10.5% of his sales. Set up an equation to find the total sales: $525 = \frac{10.5}{100}x$ where x is the amount of the sales. Solving this equation, $x = 5000$. (We'll review how to set up and solve equations like this in later chapters.)

To answer this question, you'd enter 5,000 into the box. Alternately, you could transfer your work directly from the on-screen calculator to the text box.



MAXIMIZE YOUR SCORE

As you're probably aware by now, doing well on the Math section will involve more than just knowing some math. It will also require the use of some good strategies. Let's go through some good strategies now. Make sure you read this section carefully; it will be important for you to keep these techniques in mind as you work through the content chapters that follow this one!

The Two Roles of Techniques

The techniques are there to ensure that the questions that you should get right, you do get right. A couple of careless errors on easy questions will kill your score. The techniques are not just tools; they are proven standard approaches that save time and effort and

guarantee points. Use these techniques on every question. Turn them into habits that you use every time.

Take the Easy Test First

The new GRE offers the opportunity to mark a question and return to it. Since all questions count equally toward your score, why not do the easy ones first? Getting questions right is far more important than getting to every question, so start with the low hanging fruit. There is no law that says you have to take the test in the order in which it is given. If you see a question you don't like, keep moving. Play to your strengths and get all of the questions that you're good at in the bank, before you start spending time on the hard ones. It makes no sense to spend valuable minutes wrestling with hard questions while there are still easy ones on the table. It makes even less sense if you end up having

to rush some easy ones (making mistakes in the process), as a result. Free yourself from numerical hegemony! Take the easy test first!

Bend, Don't Push

Eighty percent of the errors on the math side of the test are really reading errors. It is a four-hour test and at some point during these four hours your brain is going to get tired. When this happens you will read, see, or understand questions incorrectly. Once you see a problem wrong, it is nearly impossible to see it correctly. When this happens, even simple problems can become extremely frustrating. If you solve a problem and your answer is not one of the choices, this is what has happened. When you would swear that a problem can't be solved, this is what has happened. When you have absolutely no idea how to solve a problem, this is

what has happened. If you find yourself with half a page full of calculations and are no closer to the answer, this is what has happened. You are in La La Land. Once you are in La La Land, you can continue to push on that problem all day and you won't get any closer.

There is a good chance that you are already familiar with this frustration. The first step is to learn to recognize it when it is happening. Here are some keys to recognizing when you are off track.

You know you are in La La Land when...

- You have spent more than three minutes on a single problem.
- Your hand is not moving.
- You don't know what to do next.
- Your answer is not one of the choices.

- You're spending lots of time with the calculator and working with some ugly numbers.

Once you recognize that you are in La La Land, get out. Continuing to push on a problem, at this point, is a waste of your time. You could easily spend three or four precious minutes on this problem and be no closer to the answer. Spend those three or four minutes on other questions. That time should be yielding you points, not frustration.

After you have done two or three other questions, return to the one that was giving you trouble. Most likely, the reason it was giving you trouble is that you missed something or misread something the first time around. If the problem is still difficult, walk away again.



This is called Bend, Don't Push. The minute you encounter any resistance on the test, walk away. Bend. There are plenty of other easier points for you to get with that time. Then return to the problem a few questions later. It's okay to take two or three runs at a tough problem. If you run out of time before returning to the question, so be it. Your time is better spent on easier problems anyway, since all problems count the same.

Forcing yourself to walk away can be difficult, especially when you have already invested time in a question. You will have to train yourself to recognize resistance when it occurs, to walk away, and then to remember to come back. Employ this technique anytime you are practicing for the GRE. It will take

some time to master. Be patient and give it a chance to work. With this technique, there are no questions that are out of your reach on the GRE.

POE: Ballparking and Trap Answers

Use Process of Elimination whenever you can on questions that are in standard multiple-choice format. Always read the answer choices before you start to solve a math problem because often they will help guide you—you might even be able to eliminate a couple of answer choices before you begin to calculate the answer.

Two effective POE tools are Ballparking and Trap Answers.

You Know More Than You Think

Say you were asked to find 30 percent of 50. Wait—don't do any math yet. Let's say that you glance at the answer choices and you see these:

- 5
- 15
- 30
- 80
- 150

Think about it. Whatever 30 percent of 50 is, it must be less than 50, right? So any answer choice that's greater than 50 can't be right. That means you should eliminate both (D) and (E) before you even do any calculations! Thirty percent is less than half, so we can get rid of anything greater than 25, which means

that choice (C) is gone too. What is 10% of 50? Eliminate choice (A). You're done. The only answer left is (B). This process is known as Ballparking. Remember that the answers are part of the question. There are more than four times the number of wrong answers on the GRE as there are right ones. If it were easy to find the right ones, you wouldn't need this book. It is almost always easier to identify and eliminate the wrong answers than it is to calculate the right one. Just make sure that you are using your scratch paper to eliminate answer choices instead of keeping track in your head.

Ballparking helps you eliminate answer choices and increases your odds of zeroing in on the correct answer. The key is to eliminate any answer choice that is “out of the ballpark.”

Let's look at another problem:

A 100-foot rope is cut so that the shorter piece is $\frac{2}{3}$ the length of the longer piece. What is the length of the shorter piece in feet?

- 75
- $66\frac{2}{3}$
- 50
- 40
- $33\frac{1}{3}$



Need More Math Review?

Check out *Math Workout* for the GRE for even more math review.

Here's How to Crack It

Now, before we dive into the calculations, let's use a little common sense. The rope is 100 feet long. If we cut the rope in half, each part would be 50 feet. However, we didn't cut the rope in half; we cut it so that there's a longer part and a shorter part. What has to be true of the shorter piece then? It has to be less than 50 feet. If it weren't, it wouldn't be shorter than the other piece. So looking at our answers, we can eliminate (A), (B), and

(C) without doing any real math. That's Ballparking. By the way, the answer is (D).

Trap Answers

ETS likes to include “trap answers” in the answer choices to their math problems. Trap answers are answer choices that appear correct upon first glance. Often these answers will look so tempting that you'll choose them without actually bothering to complete the necessary calculations. Watch out for this! If a problem seems way too easy, be careful and double-check your work.

Look at the this problem:

The price of a jacket is reduced by 10%. During a special sale, the price is discounted by another 10%. The special sale price is what percent less than the original price of the jacket?

- 15%
- 19%
- 20%
- 21%
- 25%

Here's How to Crack It

The answer might seem like it should be 20 percent. But wait a minute: Does it seem likely that the GRE is going to give you a problem that you can solve just by adding $10 + 10$? Probably not. Choice (C) is a trap answer.

To solve this problem, imagine that the original price of the jacket is \$100. After a 10 percent discount the new price is \$90. But now when we take another 10 percent discount, we're taking it from \$90, not \$100. 10 percent of 90 is 9, so we take off another \$9 from the price and our final price is \$81. That represents a 19 percent total discount because we started with a \$100 jacket. The correct answer is (B).



HOW TO STUDY

Make sure you learn the content of each of the following chapters before you go on to the next one. Don't try to cram everything in all at once. It's much better to do a small amount of studying each day over a longer period; you will master both the math concepts and the techniques if you focus on the material a little bit at a time. Just as we have been telling you in earlier chapters, let the content sink in by taking short study breaks between study sessions and giving yourself plenty of time to prepare for the GRE. Slow and steady wins the race!

Practice, Practice, Practice

Practice may not make perfect, but it sure will help. Use everyday math calculations as practice opportunities. Balance your

checkbook without a calculator! Make sure your check has been added correctly at a restaurant, and figure out the exact percentage you want to leave for a tip. The more you practice simple adding, subtracting, multiplying, and dividing on a day-to-day basis, the more your arithmetic skills will improve for the GRE.



Your Premium Portal contains tons of informational videos, practice tests, helpful articles, and more to help with your GRE preparation. Head over there and take advantage of this fantastic resource!

After you work through this book, be sure to practice doing questions on our online tests and on real GREs. There are always sample questions at www.gre.org, and practice will rapidly sharpen your test-taking skills.

Finally, unless you trust our techniques, you may be reluctant to use them fully and automatically on the real GRE. The best way to develop that trust is to practice before you get to the real test.

Summary

- The GRE contains two 35-minute Math sections. Each section has 20 questions.
- The GRE tests math concepts up to about the tenth-grade level of difficulty.
- You will be allowed to use a calculator on the GRE. The calculator is part of the on-screen display.
- The Math section employs a number of different question formats, including multiple choice, numeric entry, and quantitative comparison questions.

- Use the Two-Pass system on the Math section. Find the easier questions and do them first. Use your remaining time to work some of the more difficult questions.
- When you get stuck on a problem, walk away. Do a few other problems to distract your brain, and then return to the question that was giving you problems.
- Ballpark or estimate the answers to math questions and eliminate answers that don't make sense.
- Watch out for trap answers. If an answer seems too easy or obvious, it's probably a trap.
- Always do your work on your scratch paper, not in your head. Even when you are Ballparking, make sure that

you are eliminating answer choices on your scratch paper. If your hand isn't moving, you're stuck and you need to walk away, or you're doing work in your head, which leads to errors.

Chapter 10

Numbers and Equations

Numbers and equations form the basis of all the math questions on the GRE. Simply put, the more comfortable you are working with numbers and equations, the easier the math portion of the exam will be. This chapter gives you a review of all the basic mathematical concepts including properties of numbers, factors and multiples, exponents and square roots, and lessons on manipulating and solving equations. This chapter also introduces you to one of The Princeton Review's key mathematical strategies: Plugging In.

IN THE BEGINNING...

...there were numbers. If you wish to do well on the GRE Math section, you'll have to be comfortable working with numbers. The concepts tested on the GRE are not exceptionally difficult, but if you are even the least bit skittish about numbers you'll have a harder time working the problems.

This chapter will familiarize you with all the basics you need to know about numbers and how to work with them. If you're a math-phobe or haven't used math in a while, take it slowly and make sure you're comfortable with this chapter before moving onto the succeeding ones.

You may be a little rusty when it comes to working with numbers but you'll be surprised at how

quickly you'll become
comfortable again.

GRE MATH VOCABULARY

Quick—what's an integer? Is 0 even or odd? How many even prime numbers are there?

Before we go through our techniques for specific types of math problems, we'll acquaint ourselves with some basic vocabulary and properties of numbers. The GRE loves to test your knowledge of integers, fractions, decimals, and all those other concepts you probably learned years ago. Make sure you're comfortable with the topics in this chapter before moving on. Even if you feel fairly at ease with number concepts, you should still work through this chapter. ETS is very good at coming up with questions that require you to know ideas forwards and backwards.

The math terms we will review in this section are very simple, but that doesn't mean

they're not important. Every GRE math question uses simple terms, rules, and definitions. You absolutely need to know this math “vocabulary.” Don't worry; we will cover only the math terms that you *must* know for the GRE.

Learn your vocabulary!

Digits

Digit refers to the numbers that make up other numbers. There are 10 digits: 0, 1, 2, 3, 4, 5, 6, 7, 8, 9, and every number is made up of one or more digits. For example, the number 10,897 has five digits: 1, 0, 8, 9, and 7. Each of the digits in a number has its own name, which is designated by a place value. In the number 10,897

- 7 is the ones or units digit.
- 9 is the tens digit.

- 8 is the hundreds digit.
- 0 is the thousands digit.
- 1 is the ten-thousands digit.

Numbers

A **number** is made up of either a digit or a collection of digits. There are, of course, an infinite number of numbers. Basically, any combination of digits you can imagine is a number, which includes 0, negative numbers, fractions and decimals, and even weird numbers such as $\sqrt{2}$.

GRE problems like to try to trip you up on the difference between a number and an integer.

Integers

The **integers** are the numbers that have no fractional or decimal part, such as -6 , -5 , -4 , -3 , -2 , -1 , 0 , 1 , 2 , 3 , 4 , 5 , 6 , and so on.

Notice that fractions, such as $\frac{1}{2}$, are not integers.

Remember: Fractions are
NOT integers.

Remember that the number zero is an integer! The values of positive integers increase as they move away from 0 (6 is greater than 5); the values of negative integers decrease as they move away from zero (-6 is less than -5).

PROPERTIES OF NUMBERS AND INTEGERS

Now that you've learned the proper names for various types of numbers, let's look at properties of numbers and integers.

Positive or Negative

Numbers can be positive or negative. Negative numbers are less than zero, while positive numbers are greater than zero. Zero, itself, is neither positive nor negative—all other numbers are either positive or negative.

Even or Odd

Only integers possess the property of being even or odd. Fractions, decimals, and other non-integers cannot be described as even or

odd. Integers that are even are those that are divisible by 2; odd integers are those integers that are not divisible by 2. Put another way, even integers have a remainder of 0 when divided by 2 while odd integers have a remainder of 1 when divided by 2.

- Here are some even integers: -4 , -2 , 0 , 2 , 4 , 6 , 8 , 10 .
- Here are some odd integers: -3 , -1 , 1 , 3 , 5 , 7 , 9 , 11 .

Zero

Zero is a special little number. It is an integer, but it is neither positive nor negative. However, try to remember these facts about zero:

- 0 is even.
- 0 plus any other number is equal to that other number.

- 0 multiplied by any other number is equal to 0.
- You cannot divide by 0.

Zero has a number of special properties that are tested frequently on the GRE. Technically, zero is a multiple of every number, but this fact is rarely tested on the GRE.

Keep in Mind

- Fractions are neither even nor odd.
- Any integer is even if its units digit is even; any integer is odd if its units digit is odd.
- The results of adding and multiplying odd and even integers are as follows:
 - ? even + even = even
 - ? odd + odd = even
 - ? even + odd = odd

? even \times even = even

? odd \times odd = odd

? even \times odd = even

If you have trouble remembering some of these rules for odd and even, don't worry. As long as you remember that there are rules, you can always figure them out by plugging in numbers. Let's say you forget what happens when an odd number is multiplied by an odd number. Just pick two odd numbers, say 3 and 5, and multiply them. $3 \times 5 = 15$. Now you know: odd \times odd = odd.

Be careful: Don't confuse
odd and even with
positive and negative!

Consecutive Integers

Consecutive integers are integers listed in order of increasing value without any

integers missing in between them. Here are some examples:

- 0, 1, 2, 3, 4, 5
- -6, -5, -4, -3, -2, -1, 0
- -3, -2, -1, 0, 1, 2, 3

By the way, fractions and decimals cannot be consecutive, only integers can be consecutive. However, you can have different types of consecutive integers. For example consecutive even integers could be 2, 4, 6, 8, 10. Consecutive multiples of four could be 4, 8, 12, 16.

Absolute Value

The **absolute value** of a number is equal to its distance from 0 on the number line, which means that the absolute value of any number is always positive, whether the number itself is positive or negative. The symbol

for absolute value is a set of double lines: $| |$. Thus $|-5| = 5$, and $|5| = 5$ because both -5 and 5 are a distance of 5 from 0 on the number line.

FACTORS, MULTIPLES, AND DIVISIBILITY

Now let's look at some ways that integers are related to each other.

Factors

A **factor** of a particular integer is a number that will divide evenly into the integer in question. For example, 1, 2, 3, 4, 6, and 12 are all factors of 12 because each number divides evenly into 12. In order to find all the factors of a particular integer, write down the factors systematically in pairs of integers that, when multiplied together, make 12, starting with 1 and the integer itself:

- 1 and 12
- 2 and 6
- 3 and 4

If you always start with 1 and the integer itself and work your way up, you'll make sure you get them all.

Multiples

The **multiples** of an integer are all the integers for which the original integer is a factor. For example, the multiples of 8 are all the integers of which 8 is a factor: 8, 16, 24, 32, 40 and so on and so on. Note that there are an infinite number of multiples for any given number. Also, zero is a multiple of every number, although this concept is rarely tested on the GRE.

There are only a few factors of any number; there are many multiples of any number.

Prime Numbers

A **prime number** is an integer that only has two factors: itself and one. Thus, 37 is prime because the only integers that divide evenly into it are 1 and 37, while 10 is not prime because its factors are 1, 2, 5, and 10.

Here is a list of all the prime numbers that are less than 30: 2, 3, 5, 7, 11, 13, 17, 19, 23, 29.

Here are some other facts about primes that are important to remember:

- 0 is not a prime number.
- 1 is not a prime number.
- 2 is the only even prime number.
- Prime numbers are positive integers. There's no such thing as a negative prime number or a prime fraction.

1 is not prime!

DIVISIBILITY

An integer is always divisible by its factors. If you're not sure if one integer is divisible by another, a surefire way to find out is to use the calculator. However, there are also certain rules you can use to determine whether one integer is a factor of another.

- An integer is divisible by 2 if its units digit is divisible by 2. For example, we know just by glancing at it that 598,447,896 is divisible by 2, because the units digit, 6, is divisible by 2.
- An integer is divisible by 3 if the sum of its digits is divisible by 3. For example, we know that 2,145 is divisible by 3 because $2 + 1 + 4 + 5 = 12$, and 12 is divisible by 3.
- An integer is divisible by 4 if its last two digits form a number that's

divisible by 4. For example, 712 is divisible by 4 because 12 is divisible by 4.

- An integer is divisible by 5 if its units digit is either 0 or 5. For example, 23,645 is divisible by 5 because its units digit is 5.
- An integer is divisible by 6 if it's divisible by both 2 and 3. For example, 4,290 is divisible by 6 because it is divisible by 2 (it's even) and by 3 ($4 + 2 + 9 = 15$, which is divisible by 3).
- An integer is divisible by 8 if its last three digits form a number that's divisible by 8. For example, 11,640 is divisible by 8 because 640 is divisible by 8.
- An integer is divisible by 9 if the sum of its digits is divisible by 9. For example, 1,881 is divisible by 9 because $1 + 8 + 8 + 1 = 18$, which is divisible by 9.

- An integer is divisible by 10 if its units digit is 0. For example, 1,590 is divisible by 10 because its units digit is 0.

Remainders

If one integer is not divisible by another—meaning that the second integer is not a factor of the first number—you'll have an integer left over when you divide. This left-over integer is called a **remainder**; you probably remember working with remainders in grade school.

For example, when 4 is divided by 2, there's nothing left over so there's no remainder. In other words, 4 is divisible by 2. You could also say that the remainder is 0.

If a question asks about a remainder, don't use the calculator. Use long

On the other hand, 5 divided by 2 is 2, with 1 left over; 1 is the remainder. Thirteen divided by 8 is 1, with 5 left over as the remainder.

Note that remainders are always less than the number that you are dividing by. For example, the remainder when 13 is divided by 7 is 6. What happens if you divide 14, the next integer, by 7? The remainder is 0.



You can also think of remainders as a measure of distance from the multiples of an integer. For example, 16 is a distance of 2 from 14, which is a multiple of 7. The remainder when 16 is divided by 7 is 2. Note that the ‘distance’ is always measured from the

multiple of the number you are dividing by that is less than the integer being divided.

Here's one more thing to know about remainders. What's the remainder when 5 is divided by 6? Did you say 0? The remainder is actually 5. Why? Six goes into 5 zero times. What's left over? 5! When the positive integer you are dividing by is greater than the positive integer you are dividing, the remainder is just the number being divided.

MORE MATH VOCABULARY

In a way, the Math section is almost as much of a vocabulary test as the Verbal section. Below, you'll find some more standard terms that you should commit to memory before you do any practice problems.

Term	Meaning
<i>sum</i>	the result of addition
<i>difference</i>	the result of subtraction
<i>product</i>	the result of multiplication
<i>quotient</i>	the result of division
<i>divisor</i>	the number you divide by

<i>numerator</i>	the top number in a fraction
<i>denominator</i>	the bottom number in a fraction
<i>consecutive</i>	in order from least to greatest
<i>terms</i>	the numbers and expressions used in an equation

BASIC OPERATIONS WITH NUMBERS

Now that you've learned about numbers and their properties, you're ready to begin working with them. As we mentioned above, there are four basic operations you can perform on a number: addition, subtraction, multiplication, and division.

Order of Operations

When you work with numbers you can't just perform the four operations in any way you please. Instead, there are some very specific rules to follow, which are commonly referred to as the **order of operations**.

It is absolutely necessary that you perform these operations in exactly the right order. In many cases, the correct order will be

apparent from the way the problem is written. In cases in which the correct order is not apparent, you need to remember the following mnemonic.

**Please Excuse My Dear Aunt Sally, or
PEMDAS.**

What does PEMDAS stand for?

P | E | MD | AS
→ →

P stands for “parentheses.” Solve anything in parentheses first.

E stands for “exponents.” Solve exponents next. (We’ll review exponents soon.)

M stands for “multiplication” and **D** stands for “division.” The arrow indicates that you do all the multiplication and division together in the same step, going from left to right.

A stands for “addition” and **S** stands for “subtraction.” Again, the arrow indicates that you do all the addition and subtraction together in one step, from left to right.

Let’s look at an example:



$$12 + 4(2 + 1)^2 \div 6 - 7 =$$

Here’s How to Crack It

Start by doing all the math inside the parentheses. $2 + 1 = 3$. Now the problem looks like this:

$$12 + 4(3)^2 \div 6 - 7 =$$

Next we have to apply the exponent. $3^2 = 9$.
Now this is what we have:

$$12 + 4(9) \div 6 - 7 =$$

Now we do multiplication and division from left to right. $4 \times 9 = 36$, and $36 \div 6 = 6$, which gives us

$$12 + 6 - 7 =$$

Finally, we do the addition and subtraction from left to right. $12 + 6 = 18$, and $18 - 7 = 11$. Therefore,

$$12 + 4(2 + 1)^2 \div 6 - 7 = 11$$



Multiplication and Division

When multiplying or dividing, keep the following rules in mind:

- positive \times positive = positive $2 \times 2 = 4$

- negative \times negative = positive $-2 \times -2 = 4$

- positive \times negative = negative $2 \times -2 = -4$

- positive \div positive = positive $8 \div 2 = 4$

- negative \div negative = positive $-8 \div -2 = 4$

- positive \div negative = negative $8 \div -2 = -4$

Before taking the GRE, you should have your times tables memorized from 1 through 15. It will be a tremendous advantage if you can quickly and confidently recall that $7 \times 12 = 84$, for example.

It seems like a small thing,
but memorizing your times
tables will really help you
on test day.

A FEW LAWS

These two basic laws are not necessary for success on the GRE, so if you have trouble with them, don't worry too much. However, ETS likes to use these laws to make certain math problems more difficult. If you're comfortable with these two laws, you'll be able to simplify problems using them, so it's definitely worth it to use them.

Associative Laws

There are two associative laws—one for addition and one for multiplication. For the sake of simplicity, we've lumped them together.

Here's what you need to know:

When you are adding or multiplying a series of numbers, you can regroup the numbers in any way you'd like.

Here are some examples:

$$\begin{aligned}4 + (5 + 8) &= (4 + 5) + 8 = (4 + 8) + 5 \\(a + b) + (c + d) &= a + (b + c + d) \\4 \times (5 \times 8) &= (4 \times 5) \times 8 = (4 \times 8) \times 5 \\(ab)(cd) &= a(bcd)\end{aligned}$$

Distributive Law

This is often tested on the GRE. Here's what it looks like:

$$\begin{aligned}a(b + c) &= ab + ac \\a(b - c) &= ab - ac\end{aligned}$$

Here's an example:

$$12(66) + 12(24) = ?$$

Here's How to Crack It

This is in the same form as $ab + ac$. Using the distributive law, this must equal $12(66 + 24)$, or $12(90) = 1,080$.



EXPONENTS AND SQUARE ROOTS

Exponents and square roots are a popular topic on the GRE. Here's the information you need to know in order to work with them.



What Are Exponents?

Exponents are a sort of mathematical shorthand for repeated multiplication. Instead of writing $(2)(2)(2)(2)$, you can use an exponent and write 2^4 . The little 4 is the **exponent** and the 2 is called the **base**. If you're stuck on an exponent problem, it's often helpful to write out the repeated

multiplication: When in doubt, expand it out!

There are only five rules for exponents:

$$1. \quad a^2 = a \cdot a$$

$$2. \quad a^2 \cdot a^3 = (a \cdot a)(a \cdot a \cdot a) = a^{2+3} = a^5$$

$$3. \quad (a^2)^3 = (a \cdot a) (a \cdot a) (a \cdot a) = a^{2 \cdot 3} = a^6$$

$$4. \quad \frac{a^2}{a^3} = \frac{a \cdot a}{a \cdot a \cdot a} = \frac{1}{a} = a^{2-3} = a^{-1}$$

$$5. \quad 15^{12} - 15^{11} = 15^{11}(15 - 1) = 15^{11}(14)$$

Multiplication with Exponents

It's simple to multiply two or more numbers that are raised to exponents, as long as they have the same base. In this situation, all you have to do is add the exponents. Consider this example:

$$\begin{aligned} 2^2 \times 2^4 &= \\ 2^{2+4} &= 2^6 \end{aligned}$$

You can see that this is true when you expand it out, which is just as good a way to solve the problem:

$$\begin{aligned}2^2 \times 2^4 &= \\2 \times 2 \times 2 \times 2 \times 2 \times 2 &= 2^6\end{aligned}$$

Be careful, though. This rule does not apply to addition. $2^2 + 2^4$ does not equal 2^6 . There's no quick and easy method for adding numbers with exponents.

If the numbers have the same bases, however, you can factor. So, $2^2 + 2^4 = 2^2(1 + 2^2)$. Note how this operation uses both the distributive law and the multiply-add exponent rule. ETS sometimes writes answers in this factored fashion.

Division with Exponents

Dividing two or more numbers with the same base that are raised to exponents is

simple, too. All you have to do is subtract the exponents. Study the following example:

$$2^6 \div 2^2 = 2^{6-2} = 2^4$$

You can see that this is true when you expand it out:

$$2^6 \div 2^2 = \frac{2^6}{2^2} = \frac{2 \times 2 \times 2 \times 2 \times 2 \times 2}{2 \times 2} = 2 \times 2 \times 2 \times 2 = 2^4$$

Once again, don't assume this same shortcut applies to subtraction of numbers with exponents. It doesn't. So, $2^6 - 2^2$ does not equal 2^4 . However, you could factor this expression: $2^6 - 2^2 = 2^2(2^4 - 1)$. This operation also makes use of both the distributive law and the multiply-add exponent rule. Be on the lookout for ETS to write answers in this fashion sometimes.

Another time you might need to divide with exponents is when you see a negative

exponent. In this situation, you just put 1 over the entire expression (in other words, take its reciprocal) and write the negative exponent as a positive exponent. For example,

$$3^{-2}$$

gets rewritten as

$$\frac{1}{3^2}$$

which is

$$\frac{1}{9}$$

Exponents to Exponents

When a number with an exponent is raised to another power, you simply multiply the exponents:

$$\begin{aligned}(4^5)^2 &= \\ 4^{5 \times 2} &= \\ 4^{10}\end{aligned}$$

This is what the shorthand notation is really telling us to do:

$$(4^5)^2 = (4 \times 4 \times 4 \times 4 \times 4)(4 \times 4 \times 4 \times 4 \times 4) = 4^{10}$$

Remember that the exponent applies to *everything* inside the parentheses. For example, $(3x)^2 = (3x)(3x) = 9x^2$, not $3x^2$ and not $9x$. The same is true of fractions raised to

exponents: $\left(\frac{3}{2}\right)^2 = \left(\frac{3}{2}\right)\left(\frac{3}{2}\right) = \frac{9}{4}$. When

working with fractions, remember that the exponent gets applied to both the numerator and the denominator.

The Peculiar Behavior of Exponents

- Raising a number greater than 1 to a power greater than 1 results in a bigger number. For example, $2^2 = 4$.
- Raising a fraction that's between 0 and 1 to a power greater than 1 results in a smaller number. For example, $\left(\frac{1}{2}\right)^2 = \frac{1}{4}$.
- A negative number raised to an even power results in a positive number. For example, $(-2)^2 = 4$, because $(-2)(-2) = 4$.
- A negative number raised to an odd power results in a negative number.

For example, $(-2)^3 = -8$, because $(-2)(-2)(-2) = -8$.

- A number raised to a negative power is equal to the reciprocal of the number raised to the positive power. For example, $2^{-2} = \frac{1}{2^2} = \frac{1}{4}$
- Any nonzero number raised to the 0 power is 1, no matter what the number is. For example, $1,000^0 = 1$. Note, however, that 0 to the 0 power is undefined.
- A number raised to the first power ALWAYS results in the number itself. For example, $1,000^1 = 1,000$.

Here's an example of a question you might see on the GRE:

If $a \neq 0$, then $\frac{(a^6)^2}{a \times a^2} =$

- a^5
- a^6
- a^7
- a^8
- a^9

Always cross off wrong answer choices on your scratch paper.

Here's How to Crack It

In the numerator, we have $(a^6)^2$, which is a^{12} . In the denominator, we have $a \times a^2$,

which is a^3 . So, $a^{12} \div a^3 = a^9$. That's choice (E).



Let's try another—this time, a quant comp:



Quantity A

$$27^4$$

Quantity B

$$9^6$$

- Quantity A is greater.
- Quantity B is greater.
- The two quantities are equal.
- The relationship cannot be determined from the information given.

ALWAYS write down A, B,

Here's How to Crack It

Looks scary, huh? But remember what you learned about quant comp problems in the math introduction. Your job is to compare the two quantities, not calculate their values. First of all, eliminate (D)—when only numbers are being compared, the answer can always be determined. Now, as they're written, we can't compare these numbers with exponents—they don't have the same base. But we can fix that. Both 27 and 9 are powers of 3: 27 is $3 \times 3 \times 3$, so 27^4 is $(3 \times 3 \times 3)^4$. This equals $(3 \times 3 \times 3)(3 \times 3 \times 3)(3 \times 3 \times 3)(3 \times 3 \times 3)$, also known as 3^{12} . That takes care of Quantity A. In Quantity B, 9 is 3×3 , so 9^6 is $(3 \times 3)^6$. This equals $(3 \times 3)(3 \times 3)(3 \times 3)(3 \times 3)(3 \times 3)(3 \times 3)$, also known as 3^{12} . So, we have 3^{12} in Quantity A and 3^{12} in Quantity B. They're equal, and the answer is (C).

What Is a Square Root?

The sign $\sqrt{\quad}$ indicates the **square root** of a number. For example, $\sqrt{2}$ means that some value, times itself (or squared), equals 2. Numbers that have integer square roots, for example, $\sqrt{9} = 3$, are known as **perfect squares**. In this case, 9 is the perfect square.

If $x^2 = 16$, then $x = \pm 4$. You must be especially careful to remember this on quantitative comparison questions. But when ETS asks you for the value of $\sqrt{16}$, or the square root of any number, it is asking you for the positive root only. Although squaring -5 will result in 25, just as squaring 5 will, when ETS asks for $\sqrt{25}$, the only answer it's looking for is 5.

Playing with Square Roots

There are rules that allow you to multiply and divide square roots.

You can multiply and divide any square roots, but you can add or subtract roots only when the number under the radical sign is the same

To multiply square roots:

$$\sqrt{a} \times \sqrt{b} = \sqrt{ab}$$

For example, $\sqrt{3} \times \sqrt{12} = \sqrt{36} = 6$

To divide square roots or take the

square root of a fraction: $\sqrt{\frac{a}{b}} = \frac{\sqrt{a}}{\sqrt{b}}$

648/1507

For example, $\sqrt{\frac{16}{4}} = \frac{\sqrt{16}}{\sqrt{4}} = \frac{4}{2} = 2$

However, you can't add or subtract square roots unless the roots are the same. So, $\sqrt{2} + \sqrt{2} = 2\sqrt{2}$. (Just pretend there's an invisible 1 in front of the root sign.) But $\sqrt{2} + \sqrt{3}$ does **not** equal $\sqrt{5}$. In order to add different roots, you need to estimate their values first and then add them. We'll cover how to estimate roots in the pages to come.

Here's an example:

$$z^2 = 144$$

Quantity A

z

Quantity B

$\sqrt{144}$

- Quantity A is greater.
- Quantity B is greater.
- The two quantities are equal.
- The relationship cannot be determined from the information given.

Here's How to Crack It

You want to pick choice (C), don't you? After all, if z^2 is 144, then the square root of 144 must be z , right? Not so fast. If $z^2 = 144$, then z could be either 12 or -12 . But when the radical sign ($\sqrt{\quad}$) is used, only the positive root is being referred to. Therefore, Quantity

A is equal to 12 or -12 , but Quantity B is 12. And that means that (D) is the answer.

Estimating and Simplifying Roots

When you have a perfect square, such as 25 or 36, finding the square root is easy. $\sqrt{25} = 5$ and $\sqrt{36} = 6$. But what about $\sqrt{32}$? You could use the calculator, although that may be too time-consuming. Since 32 is between 25 and 36, you can estimate that $\sqrt{32}$ must be between $\sqrt{25}$ and $\sqrt{36}$. So $\sqrt{32}$ is somewhere between 5 and 6. You also know that 32 is closer to 36 than it is to 25, so $\sqrt{32}$ will be closer to 6 than it is to 5, and will probably be about 5.6 or 5.7 (it's actually 5.66). This process of estimating roots for numbers that aren't perfect squares can be extremely

helpful in eliminating answer choices through Ballparking.

The other thing you might be able to do with a root is simplify it using the rule for multiplying roots. As we've seen, 32 isn't a perfect square, but one of its factors is a perfect square. 32 can be split into 16×2 , which means that $\sqrt{32}$ is the same thing as $\sqrt{16 \times 2}$. We can get the square root of 16 and move that outside the square root symbol, giving us $4\sqrt{2}$. $4\sqrt{2}$ has exactly the same value as $\sqrt{32}$, it's just written in simpler form. Since, on the GRE, answer choices will nearly always be written in simplest terms, it's important to know how to do this. Just start by rewriting the number under the radical as a product of two of its factors. As long as at least one of the factors is a perfect square, you'll be able to simplify the root.

Try the following problem:

**To Simplify Roots:**

1. Rewrite the number as the product of two factors, one of which is a perfect square.
2. Use the multiplication rule for roots.

$$\frac{\sqrt{75}}{\sqrt{27}} =$$

$\frac{5}{3}$

$\frac{25}{9}$

3

$3\sqrt{3}$

$3\sqrt{5}$

Here's How to Crack It

First, let's try to simplify each of these roots.

$\sqrt{75}$ has a factor that is a perfect square—25,

so it can be rewritten as $\sqrt{25 \times 3}$ and simpli-

fied to $5\sqrt{3}$. $\sqrt{27}$ has the perfect square 9 as

a factor, so it can be written as $\sqrt{9 \times 3}$ and

then simplified to $3\sqrt{3}$. This means that

$\frac{\sqrt{75}}{\sqrt{27}}$ is equal to $\frac{5\sqrt{3}}{3\sqrt{3}}$; the $\sqrt{3}$ in the

numerator and denominator cancel, leaving you with $\frac{5}{3}$. The answer is (A).

Learn These Four Values

To make calculations of square roots easier, you should memorize the following values. You should be able to recite them without hesitation.

$$\sqrt{1} = 1$$

$$\sqrt{2} \approx 1.4$$

$$\sqrt{3} \approx 1.7$$

$$\sqrt{4} = 2$$

You'll see them again when we discuss geometry, in [Chapter 12](#).

ALGEBRA: OPERATIONS WITH VARIABLES

Algebra is simply a way of performing operations without numbers; in algebraic expressions, a **variable** stands in for the unknown number or numbers. While the GRE Math section is not, by and large, an algebra test, you should be comfortable with the basics of working with equations.

Dealing with Variables

Now that you've familiarized yourself with number concepts, it's time to put your knowledge to work. So far, we've been showing you how to manipulate numbers, but many GRE math problems involve variables (such as n , x , or y). It's time to learn how to deal with those.

Manipulating Equations

When working with equations, you can do pretty much anything you want to them as long as you follow the golden rule:

Whatever you do on one side of the equals sign you must also do on the other side.

Solving for One Variable

You can solve equations that have just one variable. In these cases, you start by isolating the variable on one side of the equation and the numbers on the other side. You can do this by adding, subtracting, multiplying, or dividing both sides of the equation by the same number. Just remember that anything you do to one side of an equation, you must

do to the other side. Be sure to write down every step. Let's look at a simple example:

$$3x - 4 = 5$$

Don't assume you'll always need to solve for the variable on the GRE; sometimes you'll simply have to manipulate the equation to get the answer.

Here's How to Crack It

In this case, you can collect all the constants on the right side of the equation by adding 4 to both sides of the equation. (If you wanted to move the 5 to the left side of the equation, you would subtract 5 from both sides. That's just how it works.) In general, you can

eliminate negative numbers by adding them to both sides of the equation, just as you can eliminate positives by subtracting them from both sides of the equation.

$$\begin{array}{r} 3x - 4 = 5 \\ + 4 = + 4 \\ \hline 3x = 9 \end{array}$$

The rule above also applies to numbers in the equation that are divided or multiplied. So in this case, in order to get rid of the 3 that's multiplied by the variable, x , we need to divide both sides of the equation by 3 to solve for x .

$$\begin{array}{r} \frac{3x}{3} = \frac{9}{3} \\ x = 3 \end{array}$$



Let's try another one:

$$5x - 13 = 12 - 20x$$

Here's How to Crack It

Again, we want to get all the x values on the same side of the equation:

$$\begin{array}{r} 5x - 13 = 12 - 20x \\ + 20x \qquad \qquad \qquad + 20x \\ \hline 25x - 13 = 12 \end{array}$$

Always write A, B, C, D, E on your scratch paper to represent the answer choices (or A, B, C, D if it's quant comp).

Now let's get rid of that negative 13:

$$\begin{array}{r} 25x - 13 = 12 \\ + 13 + 13 \\ \hline 25x = 25 \end{array}$$

It might be pretty obvious that x is 1, but let's just finish it:

$$\begin{aligned}25x &= 25 \\ \frac{25x}{25} &= \frac{25}{25} \\ x &= 1\end{aligned}$$



Let's try another one:



$$5x + \frac{3}{2} = 7x$$

Here's How to Crack It

First multiply both sides by 2 to get rid of the fraction. (This is called clearing the fraction, by the way, and is a very useful way to start solving an equation that contains fractions.)

Remember to multiply all of the terms of the equation!

$$10x + 3 = 14x$$

You must always do the same thing to both sides of an equation.

Now collect the x 's on the same side:

$$\begin{array}{r} 10x + 3 = 14x \\ -10x \quad -10x \\ \hline 3 = 4x \end{array}$$

Now finish it up:

$$\begin{aligned} 3 &= 4x \\ \frac{3}{4} &= \frac{4x}{4} \\ \frac{3}{4} &= x \end{aligned}$$



INEQUALITIES

In an equation, one side is always equal to another. In an inequality, one side of the equation does *not* equal the other. Equations contain equal signs, while inequalities contain one of the following symbols:

\neq	is not equal to
$>$	is greater than
$<$	is less than
\geq	is greater than or equal to
\leq	is less than or equal to



The point of the inequality sign always points to the smaller value.

You can manipulate any inequality in the same way you can an equation, with one important difference. When you multiply or divide both sides of an inequality by a negative number, the direction of the inequality symbol must change. That is, if $x > y$, then $-x < -y$.

To see this rule in action, take a look at this simple inequality:



$$12 - 6x > 0$$

Here's How to Crack It

You could manipulate this inequality without ever multiplying or dividing by a negative number by just adding $6x$ to both sides. The sign stays the same. Then divide both sides by positive 6 . Again, the sign stays the same.

$$\begin{aligned} 12 - 6x &> 0 \\ + 6x &> + 6x \\ \hline 12 &> 6x \\ \frac{12}{6} &> \frac{6x}{6} \\ 2 &> x \end{aligned}$$

But suppose you subtract 12 from both sides at first:

$$\begin{aligned} 12 - 6x &> 0 \\ -12 &> -12 \\ \hline -6x &> -12 \\ \frac{-6x}{-6} &< \frac{-12}{-6} \\ x &< 2 \end{aligned}$$

Flip the sign! When you

multiply or divide both sides of an inequality by a negative number, the greater than/less than sign points the opposite way.

Notice that the sign flipped because you divided both sides by a negative number. But the answer means the same thing: The first answer says that the number 2 is greater than x , and the second says that x is less than the number 2!



Sometimes, ETS will give you a range for two variables and then combine them in some way. It looks something like this:



If $0 \leq x \leq 10$, and $-10 \leq y \leq -1$, then what is the range for $x - y$?

Here's How to Crack It

First, treat the inequality sign like an equal sign. You need all possible combinations of $x - y$, which means that you need the biggest x minus the biggest y , the biggest x minus the smallest y , the smallest x minus the biggest y , and the smallest x minus the smallest y . There is a simple set-up to do this.

On your scratch paper write the following:

	x	y	$x - y$
B	B		
B	S		
S	B		
S	S		

Now just solve for $x - y$. When you're done, the biggest and smallest numbers are your answers.

	x		y	$x - y$
B	10	B	-1	11
B	10	S	-10	20
S	0	B	-1	1
S	0	S	-10	10

The range for $x - y$, therefore is $1 \leq x - y \leq 20$. Check your answer choices and eliminate.



WORKING WITH TWO VARIABLES

So far we've dealt with simple equations that involve only one variable. But on the GRE you'll sometimes have to deal with equations with two variables. Here's an example:

$$3x + 10y = 64$$

Here's How to Crack It

The important thing to note about this situation is that we cannot solve this equation. Why, you ask? The problem is that since there are two variables, there are many possible solutions to this equation all of which are equally valid. For example, the values $x = 8$ and $y = 4$ satisfy the equation. But so do

the values $x = 10$ and $y = 3.4$. In order to solve equations with two variables for a unique solution, we need two equations. Having two equations allows us to find definitive values for our variables.

$$3x + 10y = 64$$

$$6x - 10y = 8$$



You can't solve an equation with two variables unless you have a second equation.

When we're given two equations, we can combine them by adding or subtracting them. We do this so that we can cancel out one of the variables, leaving us with a simple

equation with one variable. In this case, it's easier to add the two equations together:

$$\begin{array}{r} 3x + 10y = 64 \\ 6x - 10y = 8 \\ \hline 9x \qquad = 72 \end{array}$$

When we add these two equations we get $9x = 72$. This is a simple equation which we can solve to find $x = 8$. Once we've done that, we plug that value back into one of the equations and solve for the other variable. For example, if we substitute $x = 8$ into the first equation, we get $3(8) + 10y = 64$, we can solve to find that $y = 4$.



Try this one:



$$\begin{array}{r} 4x + 7y = 41 \\ 2x + 3y = 19 \end{array}$$

Here's How to Crack It

You might notice that if we add or subtract the two equations, we won't be left with one variable: Adding the two yields $6x + 10y = 60$. That doesn't help. Subtracting the equations leaves $2x + 4y = 22$. No help there, either. In cases like this one, you'll have to manipulate one of the equations so that subtracting or adding gets rid of one of the variables. In this case, let's multiply the second equation by 2:

$$2(2x + 3y) = 2(19)$$

This gives us the following:

$$4x + 6y = 38$$

Now we can subtract this equation from the first equation, yielding $y = 3$. If we substitute $y = 3$ into either of the equations we find that $x = 5$.

Quadratic Equations

Quadratic equations are special types of equations that involve, as the name suggests, four terms. Here is an example of a quadratic:

$$(x + 4)(x - 7)$$

In order to work with quadratics on the GRE, you must be familiar with two concepts: FOIL and factoring.

FOIL

When you see two sets of parentheses, all you have to do is remember to multiply every term in the first set of parentheses by every term in the second set of parentheses. Use FOIL to remember this method. FOIL stands

for *first*, *outer*, *inner*, *last*—the four steps of multiplication. For example, if you see $(x + 4)(x + 3)$, you would multiply the first terms ($x \times x$), the outer terms ($x \times 3$), the inner terms ($4 \times x$), and the last terms (4×3), as follows:

$$\begin{aligned}(x \times x) + (x \times 3) + (4 \times x) + (4 \times 3) &= \\ x^2 + 3x + 4x + 12 &= \\ x^2 + 7x + 12 &\end{aligned}$$

This also works in the opposite direction. For example, if you were given $x^2 + 7x + 12 = 0$, you could solve it by breaking it down as follows:

$$(x + \) (x + \) = 0$$

Quadratic Equations

There are quadratic equations that frequently appear on the GRE. You should

know them cold, in both their factored and unfactored forms. Here they are:

1. Factored form: $x^2 - y^2$ (the difference between two squares)
Unfactored form: $(x + y)(x - y)$
2. Factored form: $(x + y)^2$
Unfactored form: $x^2 + 2xy + y^2$
3. Factored form: $(x - y)^2$
Unfactored form: $x^2 - 2xy + y^2$

We know to use plus signs inside the parentheses because both the 7 and the 12 are positive. Now we have to think of two numbers that, when added together, give us 7, and when multiplied together, give us 12. Yep, they're 4 and 3:

$$(x + 4)(x + 3) = 0$$

To find the solutions, set each factor equal to 0 and solve. So, $x + 4 = 0$ and $x + 3 = 0$. So x can either be -4 or -3 .

Let's see how this could be used on the GRE:

If x and y are positive integers, and if $x^2 + 2xy + y^2 = 25$, then $(x + y)^3 =$

- 5
- 15
- 50
- 75
- 125

Here's How to Crack It

Problems like this one are the reason you have to memorize those common quadratic equations. The equation in this question is the second expression in the box from the previous page: $x^2 + 2xy + y^2 = (x + y)^2$. The question tells us that $x^2 + 2xy + y^2$ is equal to 25, which means that $(x + y)^2$ is also equal to 25. Think of $x + y$ as one unit that, when squared, is equal to 25. Since this question specifies that x and y are positive integers, what positive integer squared equals 25? Right, 5. So $x + y = 5$. The question is asking for $(x + y)^3$. In other words, what's 5 cubed, or $5 \times 5 \times 5$? It's 125. Choice (E).



Here's another one:



Quantity A

$$(4 + \sqrt{6})(4 - \sqrt{6})$$

Quantity B

$$10$$

- Quantity A is greater.
- Quantity B is greater.
- The two quantities are equal.
- The relationship cannot be determined from the information given.

Here's How to Crack It

First, eliminate choice (D)—we have only numbers here, so the answer can be determined. Now, Quantity A looks like a job for FOIL! Multiply the first terms, and you get 16. Multiply the outer terms and you get $-4\sqrt{6}$. Multiply the inner terms and you get 4

$\sqrt{6}$. Multiply the last terms and you get -6 . So, we have $16 - 4\sqrt{6} + 4\sqrt{6} - 6$. Those two inner terms cancel each other out, and we're left with $16 - 6$, or 10 . What do you know? That's what we have in Quantity B, too! So, the answer is (C). You might also notice that Quantity A is the first common quadratic from the box on [this page](#): $(x + y)(x - y) = x^2 - y^2$. Therefore, $(4 + \sqrt{6})(4 - \sqrt{6}) = 4^2 - \sqrt{6}^2 = 16 - 6 = 10$.

Factoring

The process of factoring “undoes” the FOIL process. Here is a quadratic in its unfactored, or expanded, form:

$$x^2 - 10x + 24$$

From this point, we can factor a quadratic by taking the following steps:

1. Separate the x^2 into $(x \quad)(x \quad)$.
2. Find the factors of the third term that, when added or subtracted, yield the second term.
3. Figure out the signs (+/-) for the terms. The signs have to yield the middle number when added and the last term when multiplied.

If we apply these steps to the expression above, we first set up the problem by splitting x^2 into

$$(x \quad)(x \quad)$$

Next, write down the factors of the third term, 24. The factors are 1 and 24, 2 and 12, 3 and 8, and 4 and 6. Of these pairs of factors, which contains two numbers that we can add or subtract to get the second term,

10? 4 and 6 are the only two that work. That gives us

$$(x - 4)(x - 6)$$

The final step is to figure out the signs. We need to end up with a negative 10 and a positive 24. If we add -6 and -4 , we'll get -10 . Similarly, if we multiply -6 and -4 , we'll end up with 24. So the factored form of the expression is

$$(x - 4)(x - 6)$$

Solving Quadratic Equations

ETS likes to use quadratic equations because they have an interesting quirk; when you solve a quadratic equation, you usually get not one answer, but two. For this reason,

quadratic equations are perfect ways for ETS to try to trick you.

Here's an example:



$$x^2 + 2x - 15 = 0$$

Quantity A

Quantity B

2

x

- Quantity A is greater.
- Quantity B is greater.
- The two quantities are equal.
- The relationship cannot be determined from the information given.

Quadratic equations usually have two solutions.

Here's How to Crack It

In order to solve a quadratic equation, the equation must be set equal to zero. Normally, this will already be the case on the GRE, as it is in this example. But if you encounter a quadratic equation that isn't set equal to zero, you must first manipulate the equation so that it is. Next you must factor the equation; otherwise you cannot solve it. So let's factor the quadratic equation in this example. We need to figure out the factors of 15 that we can add or subtract to give us 2. The only possible factors are 3 and 5. In order to get a negative 15 and a positive 2, we need to use 5 and -3 . So that leaves us

$$(x - 3)(x + 5) = 0$$

Next, we're going to solve each of the two factors within parentheses separately:

$$x - 3 = 0 \text{ and } x + 5 = 0$$

Thus, $x = 3$ and $x = -5$. If $x = 3$, then Quantity B is greater, but if $x = -5$ then Quantity A is greater. This means that the answer is (D).



Let's try another one:



If $x^2 + 8x + 16 = 0$, then $x =$

Click on the answer box and type in a number.

Backspace to erase.

Here's How to Crack It

Let's factor the equation. Start with $(x + \quad)(x + \quad)$. Next, find the factors of 16 that add or subtract to 8. The factors of 16 are 1 and 16, 2 and 8, and 4 and 4. Of these pairs, only 4 and 4 have a sum of 8. Since we have a positive 8 and a positive 16, the signs for both numbers must be positive. Thus, we end up with $(x + 4)(x + 4) = 0$. Now, we need to solve the equation. If $x + 4 = 0$, then $x = -4$. This is the number we'd enter into the text box on the GRE.

Simultaneous Equations

ETS will sometimes give you two equations and ask you to use them to find the value of a given expression. Don't worry; you won't need any math-class algebra; in most cases, all you will have to do to find ETS's answer is to add or subtract the two equations.

Here's an example:

If $5x + 4y = 6$ and $4x + 3y = 5$, then what does $x + y$ equal?

Here's How to Crack It

All you have to do is add the two equations together or subtract one from the other. Here's what we get when we add them:

$$\begin{array}{r} 5x + 4y = 6 \\ + 4x + 3y = 5 \\ \hline 9x + 7y = 11 \end{array}$$

A dead end. So let's try subtracting them:

$$\begin{array}{r} 5x + 4y = 6 \\ - 4x + 3y = 5 \\ \hline x + y = 1 \end{array}$$

Bingo. The value of the expression $(x + y)$ is exactly what we're looking for. On the GRE, you may see the two equations written horizontally. Just rewrite the two equations, putting one on top of the other, and then simply add or subtract them.



PLUGGING IN

Some of the hardest questions you might encounter on the GRE involve algebra. Algebra questions are generally difficult for two reasons. First, they are often complicated, multistep problems. Second, ETS studies the types of mistakes that people make when they solve questions using algebra. They generate wrong answers for the questions based on these common algebraic errors. So, if you aren't careful, you can make an algebraic mistake and still find your answer among the choices.

Why Plug In?

Plugging In is a powerful tool that can greatly enhance your math score, but you may be wondering why you should

plug in when algebra works just fine. Here's why:

Plugging In converts algebra problems into arithmetic problems. No matter how good you are at algebra, you're better at arithmetic. Why? Because you use arithmetic every day, every time you go to a store, balance your checkbook, or tip a waiter. Chances are you rarely use algebra in your day-to-day activities.

Plugging In is more accurate than algebra. By Plugging In real numbers, you make the problems concrete rather than abstract. Once you're working with real numbers, it's easier to notice when and where you've messed up a calculation. It's much harder to see where you went wrong (or to even know you've done

something wrong) when you're staring at a bunch of x 's and y 's.

The GRE allows the use of a calculator. A calculator can do arithmetic but it can't do algebra, so Plugging In allows you to take advantage of the calculator function.

ETS expects its students to attack the problems algebraically and many of the tricks and the traps built into the problem are designed to catch students who do the problems with algebra. By Plugging In, you'll avoid these pitfalls.

As you can see, there are a number of excellent reasons for Plugging In. Mastering this technique can have a significant impact on your score.

If you don't like algebra, you're in luck. You don't have to do it. Plugging In will take even the hardest, messiest GRE problem and turn it into a simple arithmetic problem.

Let's look at an example.

Dale gives Miranda x bottles of water. He gives Marcella two fewer bottles of water than he gives to Miranda and he gives Mary three more bottles of water than he gives to Marcella. How many bottles of water did Dale give to Miranda, Marcella and Mary, in terms of x ?

- $3x - 1$
- $3x$
- $3x + 1$

$3x + 2$

$x - 2$

Here's How to Crack It

Let's use an easy number like 10 for the variable. Be sure to write down $x = 10$ on your scratch paper. So, Miranda gets 10 bottles of water. Marcella gets two fewer bottles of water than Miranda, so Marcella gets 8 bottles. Mary gets three more bottles than Marcella, so Mary gets 11 bottles. That's a total of $10 + 8 + 11 = 29$ bottles of water. Be sure to do the calculations on your scratch paper. Circle 29 (the target answer) and Plug In 10 every time you see an x in the answer choices. Which answer equals 29 when x is 10? Be sure to check all five answers.

(A) $3(10) - 1 = 29$ Looks good!

(B) $3(10) = 30$ Nope

- (C) $3(10) + 1 = 31$ Nope
(D) $3(10) + 2 = 32$ Nope
(E) $10 - 2 = 8$ Nope

Pretty easy compared to the algebra, huh?

As you can see, Plugging In turned this algebra problem into an arithmetic problem. The best news is that you can solve any problem with variables by using Plugging In.



Here are the steps:

Step 1:

Recognize the opportunity. You can Plug In on any problem that has variables in the answer choices. The minute you see variables

in the answers, even before you have read the problem, you know you can Plug In.

Step 2:

Set up your Scratch Paper. You cannot solve Plugging In problems in your head. Even if it seems like an easy question of translating a word problem into an algebraic equation, remember that there are trap answer choices. When a question pops up, the minute you see variables, list your answer choices, A–E, on your scratch paper.

Step 3:

Plug In. If the question asks for “ x apples,” come up with a number for x . The goal here is to make your life easier, so Plug In something simple but avoid 1 or 0. If you Plug In a number and the math starts getting difficult (for example, you start getting fractions or negative numbers), don’t be afraid to

just change the number you Plug In. Always label each variable on your scratch paper.

Step 4:

Solve for the Target. The Target is the value the problem asks you to solve for. Once you've gotten a Target write it down on your scratch paper and circle it.

Step 5:

Check All Answer Choices. Anywhere you see a variable, Plug In the number you have written down for that variable. Do any required math. The correct answer is the one that matches your target number. If more than one answer matches your target number, just Plug In a different number for your variables and test the remaining answer choices.

Can I Just Plug In Anything?

You can Plug In any numbers you like, as long as they're consistent with any restrictions stated in the problem, but it's faster if you use easy numbers. What makes a number easy? That depends on the problem. In most cases, smaller numbers are easier to work with than larger numbers. Usually, it's best to start small, with 2, for example. Avoid 0 and 1; both 0 and 1 have special properties, which you'll hear more about later. You want to avoid these numbers because they will often make more than one answer choice match the target. For example, if we Plug In 0 for a variable, then the answers $2x$, $3x$, and $5x$ would all equal 0. If you avoid these bad number choices, you should also avoid these bad situations. Also, do not Plug In any numbers that show up a lot in the question or answer choices.

Plug In numbers that make
the calculations EASY.

Good Numbers Make Life Easier

Small numbers aren't always the best choices for Plugging In, though. In a problem involving percentages, for example, 10 and 100 are good numbers to use. In a problem involving minutes or seconds, 30 or 120 are often good choices. You should look for clues in the problem itself to help you choose good numbers.

Always Plug In when
you see variables in the
answer choices!

Let's work through the following problem, using the Plugging In steps from above:

Mara has six more than twice as many apples as Robert and half as many apples as Sheila. If Robert has x apples, then, in terms of x , how many apples do Mara, Robert, and Sheila have together?

- $2x + 6$
- $2x + 9$
- $3x + 12$
- $4x + 9$
- $7x + 18$

On the GRE, Plugging In is often safer, and easier, than doing the algebra.

Here's How to Crack It

Step 1:

Identify the Opportunity. You're sitting in your cubicle at the Prometric testing center and this question pops up. What do you see? The variable, x , is in both the question and the answer choices. Good, so what do you do?

Step 2:

Set up your Scratch Paper. On the upper left-hand corner of your scratch paper, list answer choices (A) through (E).

Step 3:

Plug In. The problem tells us that Robert has x apples, so Plug In a number for x . Make it something nice. Try 4. On your scratch paper, write $x = 4$.

Step 4:

Solve for the Target. The problem tells us that "Mara has six more than twice as many apples as Robert." If Robert has 4 apples,

then Mara must have 14. On your scratch paper, write $m = 14$. We are also told that Mara has “half as many apples as Sheila.” That means that Sheila must have 28 apples. Write down $s = 28$. Now, what does the question ask you to find? It asks for the number of apples that Mara, Robert, and Sheila have together. That’s no problem; add the three up to come up with 46 apples. This is your target. Write it down and circle it.

Step 5:

Check All Answer Choices. You can perform only one mathematical function in your head at a time. Anything more than that leads to trouble. For the first answer choice, therefore, you can do $2x$ in your head; that’s 8, but write down $8 + 6$. You don’t need to go any farther than that because this clearly will not add up to 46. Cross off choice (A). Choice (B) gives you $8 + 9$. Cross that off. Choice (C) is $12 + 12$. This is also too small, so cross it

off. Choice (D) gives you $16 + 9$. That gets you to 25, which is not your target number, so cross it off. Choice (E) is $28 + 18$. Do this on your scratch paper or with the calculator. Do NOT do it in your head. It equals 46, which is your target number. Choice (E) is the correct answer.

(A) $2(4) + 6 = 14$ —This is not 46, so eliminate it.

(B) $2(4) + 9 = 17$ —No good either.

(C) $3(4) + 12 = 24$ —Still not 46.

(D) $4(4) + 9 = 25$ —This isn't 46 either.

(E) $7(4) + 18 = 46$ —Bingo! This is your answer.



On the GRE, you can Plug In any time the question has variables in the answer choices. You can usually Plug In any number you wish, although you should always pick numbers that will be easy to work with. Some

numbers can end up causing more trouble than they're worth.

When a problem has variables in the answer choices, PLUG IN!

When Plugging In, follow these rules:

1. Don't Plug In 0 or 1. These numbers, while easy to work with, have special properties.
2. Don't Plug In numbers that are already in the problem; this often leads to more than one answer matching your target.
3. Don't Plug In the same number for multiple variables. For example, if a problem has x , y , and

z in it, pick three different numbers to Plug In for the three variables.

4. Avoid conversion numbers. For example, don't use 60 for a problem involving hours and minutes.

Finally, Plugging In can be a powerful tool, but you **must remember to always check all five answer choices when you plug in.** In certain cases, two answer choices can yield the same target. This doesn't necessarily mean you did anything wrong; you just hit some bad luck. Plug In some new numbers, get a new target and recheck the answers that worked the first time.



Strategy!

The following is a tried-and-true
Princeton Review
strategy (that has nothing
to do with the delicious
type of bread).

PLUGGING IN THE ANSWERS (PITA)

Some questions may not have variables in them but will try to tempt you into using algebra to solve them. We call these Plugging In The Answers, or PITA for short. These are almost always difficult problems. Once you recognize the opportunity, however, they turn into simple arithmetic questions. In fact, the hardest part of these problems is often identifying them as opportunities for PITA. The beauty of these questions is that they take advantage of one of the inherent limitations of a multiple-choice test. ETS has actually given you the answers, and one of them must be correct. In fact, only one can work. The essence of this technique is to systematically Plug In The Answers to see which answer choice works.

Let's look at an example of a Plugging In The Answers question.

Are you tempted to do algebra? Are there numbers in the answer choices? Plug In The Answers.

An office supply store sells binder clips that cost 14 cents and binder clips that cost 16 cents. If a customer purchases 85 binder clips from this store at a total cost of \$13.10, how many 14-cent binder clips does the customer purchase?

- 16
- 25
- 30

35

65

Here's How to Crack It

ETS would like you to solve this problem using algebra. You probably even started to think about the variables you could use to set up some equations to solve this problem. That urge to do algebra is actually the first sign that you can solve this problem using **Plugging In The Answers**. Other signs that you can **Plug In The Answers** to solve this problem are that the question asks for a specific amount and that there are numbers in the answer choices. With all these signs, it's definitely time to **Plug In The Answers!**

Start by setting up your scratch paper. To do so, just list the five answer choices in a column. Next, label the first column. If

you're going to work with the answer choices, you need to know what they represent. Since the question asks for the number of 14-cent binder clips, you can label this column 14¢.

When you Plug In the Answers, start with answer (C). Since the numbers are always in numerically ascending or descending order, you can cut down on the number of answers that you need to test by starting with answer (C). So, start with the idea that the customer purchased 30 binder clips that cost 14 cents each. What can you figure out with this information? You'd know that the total spent on these binder clips is $30 \times \$0.14 = \4.20 . Make a column with the heading "amount spent" and write \$4.20 next to answer (C), 30. Now, look for the next thing you'd know in this scenario. The customer purchased a total of 85 binder clips. So, that means that 55 of the 16-cent binder clips were

purchased. Make another column with the heading “16¢” and write 55 in the row for answer (C). Next, make another column for “amount spent” and write $55 \times \$0.16 = \8.80 in the same row. The next piece of information in the problem is that the customer spends a total of \$13.10 on the binder clips. This information allows you to determine if answer (C) is correct. All Plugging In the Answers questions contain a condition like this that lets you decide if the answer is right. In this case, $\$4.20 + \$8.80 = \$13.00$, which is too small. So, eliminate answer (C). Since the total was too small, more of the binder clips need to cost 16 cents. So, eliminate answers (D) and (E) as well.

Now, do the same steps starting with answer (B). If the customer purchased 25 of the 14-cent binder clips, they cost \$3.50. The customer also purchased 60 of the 16-cent binder clips at a cost of \$9.60. The total amount

spent is $\$3.50 + \$9.60 = \$13.10$. Since this matches the amount spent in the problem, answer (B) is correct.

Here's what your scratch paper should look like after this problem:

<u>14¢</u>	<u>Amt.</u>	<u>16¢</u>	<u>Amt.</u>	<u>Tot.</u>
16				
✓ 25	3.50	60	9.60	\$13.10
→ 30	4.20	55	8.80	\$13.00
35				
65				

Now, here's a recap of the steps for Plugging In the Answers.

Step 1:

Recognize the Opportunity. There are three ways to do this. The first triggers are the phrases “how much...,” “how many...,” or “what is the value of...” When you see one of these phrases in a question, you can Plug In The Answers. The second tip-off is specific numbers in the answer choices in ascending or descending order. The last tip-off is your own inclination. If you find yourself tempted to write your own algebraic formulas and to invent your own variables to solve the problem, it’s a sure bet that you can just Plug In The Answer choices.

Step 2:

Set up your Scratch Paper. The minute you recognize the opportunity, list the numbers in the answer choices in a column in the upper left-hand corner of your scratch paper.

Step 3:

Label the First Column. What do these numbers represent? The question asks you to find a specific number. The answer choices are this number. At the top of the column, write down what these numbers represent.

Step 4:

Start with Choice (C). Choice (C) will always be the number in the middle. This the most efficient place to start because it will allow you to eliminate as many as three answer choices if it is wrong.

Step 5:

Create Your Spreadsheet. Use choice (C) to work through the problem. It is always easier to understand the problem using a specific number. Work through the problem in bite-size pieces, and every time you have to do something with the number, make a new column. You can't have too many

columns. Each column is a step in solving the problem.

Step 6:

Rinse and Repeat. On single-answer multiple-choice questions, only one answer choice can work. If choice (C) is correct, you are done. If it is not correct, you may be able to determine if it is too big or too small. If it is too big, you can eliminate it and every answer choice that is bigger. This very quickly gets you down to a 50/50 shot. It also gives you a little spreadsheet specifically designed to calculate the correct answer. When you need to check the remaining answer choices, let the spreadsheet do the thinking for you. All you need to do is to fill in the cells. As soon as you find an answer choice that works, you're done.

On PITA questions, you can stop once you've found the correct answer; you don't have to

check all five answer choices. Just make sure you write **EVERYTHING** down when doing these questions (and, indeed, all math questions).

PLUGGING IN ON QUANTITATIVE COMPARISON QUESTIONS

Quantitative Comparison questions with variables can be extremely tricky because the obvious answer is often wrong, whereas finding the correct answer may involve a scenario most people would never think of. On the other hand, there is a simple set-up and approach that you can use that ensures that you get these questions right without taking too much time. As always, whenever you see variables, replace them with real numbers. On quant comp questions, however, it is crucial that you Plug In more than once and specifically that you Plug In all of the weird and obscure numbers that you would never use elsewhere. Always keep the nature of the answer choices in mind. Picking choice (A) means that you believe that the quantity in

column A will *always* be bigger—*no matter what you Plug In*. Choice (B) means that the quantity in column B will *always* be bigger—*no matter what you Plug In*, and so forth. To prove that one of these statements is true you have to Plug In every possible number that could change the outcome. Don't worry. We have a simple process to help figure out what to Plug In and how to track your progress as you do.

Quantitative Comparison questions often test your knowledge of the properties of fractions, zero, one, negatives, and other weird numbers.

Here are the steps:

Step 1:

Recognize the Opportunity. The first six, seven, or eight questions of any math section

will be quant comp. When a quant comp question pops up and you see variables, you know that you can Plug In.

Step 2:

Set up your Scratch Paper. The minute you see quant comp and variables set up your scratch paper. Your set-up looks like this:

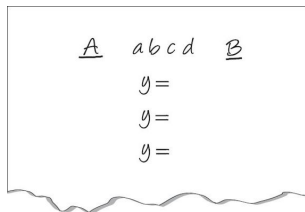

Step 3:

Plug In and Eliminate. Start with a normal number such as 2 or 5 but make sure that you also follow any conditions in the problem. With the number you Plugged In for the variable, calculate the value in

Quantity A and write it down. Then calculate the value in Quantity B and write it down. If Quantity A is greater, eliminate choices (B) and (C). If Quantity B is greater, eliminate (A) and (C). If both quantities are the same, eliminate choices (A) and (B). Note that you are already down to a 50/50 shot.

Step 4:

Rinse and Repeat. There are still two answer choices left, so you're not done yet. The second time you Plug In, you want to try to get a different result. What can you Plug In the second time that messes with the problem? If you're not sure, use this simple checklist: FROZEN. This stands for Fractions, Repeats (numbers from the problem), One, Zero, Extremes (like 100), and Negatives. You won't always be allowed to Plug In all of these and rarely will you have to. Your goal is to eliminate choices (A), (B), and (C). If you Plug In everything on the checklist and (A),

(B), or (C) is still standing, the one that's still standing is your answer.

The easiest way to solve most quant comp questions that involve variables is to Plug In, just as you would on word problems. But because answer choice (D) is always an option, you always have to make sure it isn't the answer. So...

Always Plug In at Least Twice in Quant Comp Questions

When you Plug In on Quant Comp questions, you'll need to Plug In twice because of answer (D). On quant comp questions, it's not enough to determine whether one quantity is sometimes greater than, less than, or equal to the other; you have to determine whether it *always* is. If different numbers lead to different answers, then the correct answer is

(D). To figure out if one quantity is always greater, you have to Plug In weird numbers to account for all possible situations.



On quant comp, Plug In "normal" numbers, and eliminate two choices. Then Plug In "weird" numbers (zero, one, negatives, fractions, or big numbers) to try to disprove your first answer. If different numbers give you different answers, you've proved that the answer is (D).

What makes certain numbers weird? They behave in unexpected ways when added,

multiplied, or raised to powers. Here are some examples:

- 0 times any number is 0.
- 0^2 is 0.
- 1^2 is 1.
- $\left(\frac{1}{2}\right)^2$ is less than $\frac{1}{2}$.
- $(-2)(-2)$ is 4.
- A negative number squared is positive.
- Really big numbers (100, 1,000) can make a really big difference in your answer.

ETS likes to make the correct answer depend on numbers such as these because they know that most test-takers don't think about these numbers when solving problems.

Here's how it works:



Quantity A

$$2x^3$$

Quantity B

$$4x^2$$

- Quantity A is greater.
- Quantity B is greater.
- The two quantities are equal.
- The relationship cannot be determined from the information given.

Here's How to Crack It

Step 1:

Recognize the Opportunity. First you see quant comp. Second, you see variables. It takes all of three seconds to recognize a quant comp Plug In. You don't even have to understand the problem at this point. Just recognize the opportunity.

Step 2:

Set up your Scratch Paper. The minute you recognize this as a quant comp Plug In, set up your scratch paper. List " $x =$ " three times down the middle.

Step 3:

Plug In. Let's start with a normal number like 2. Write down 2 next to your first x . When $x = 2$, the quantity in column A is 16 ($2 \cdot 2^3$), and the quantity in column B is also 16 ($4 \cdot 2^2$). Since you have followed the rules and both quantities are the same, neither (A) nor (B) can be the answer. Cross them off. Note that you haven't worked very hard yet,

haven't spent much time at all, and you are already down to a 50/50 shot.

Step 4:

Rinse and Repeat. Now try something different for x . What if $x = 1$? The quantity in column A will be 2, and the quantity in column B will be 4. In this case, they are not the same, so choice (C) cannot be the correct answer. Cross it off. Only choice (D) is left, so you're done.

Here is what your scratch paper should look like:

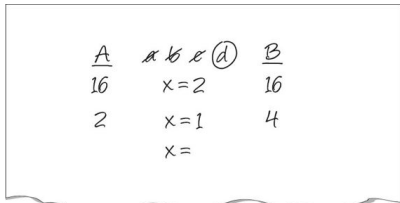

<u>A</u>	a b c (d)	<u>B</u>
16	$x=2$	16
2	$x=1$	4
	$x=$	



You might also have noticed that Plugging In $x = 0$ would also yield different results. On quant comp questions, ETS hopes you'll forget to consider what happens when you use numbers such as 0, 1, fractions, and negatives. Therefore, when Plugging In, make sure to use the following FROZEN numbers whenever possible:

Fractions
Repeats
One
Zero
Extremes
Negatives



In your Premium Portal, you can find a short video about the proper set up to maximize efficiency when using scratch paper on the GRE.

Make sure you use these numbers aggressively on quant comp problems because they can radically affect the relationship between the two quantities.

Phew. Now we've covered the basics of mathematical operations; hopefully a lot of this material came back to you as we went through it, but if not don't worry! You'll have plenty of opportunities to refresh your memory of this material as you read through the next two chapters and work the problems you see in the drills.

In the next chapter we'll look at some everyday math topics that are tested on the GRE,

so practice the techniques in the drill that follows, and move on!

Numbers and Equations

Drill

Ready to try out your new skills? Give this drill a shot and then check your answers in [Part V](#).

1 of 10

If a prime number, p , is squared and the result is added to the next prime number greater than p , which of the following could be the resulting sum?

Indicate all possible values.

3

4

7 14 58 60 65 69

2 of 10

$$x^2 + 8x = -7$$

Quantity A

Quantity B

x

0

- Quantity A is greater.
- Quantity B is greater.
- The two quantities are equal.

- The relationship cannot be determined from the information given.

3 of 10

If $3^3 \times 9^{12} = 3^x$, what is the value of x ?

Click on the answer box and type in a number.

Backspace to erase.

4 of 10

If $A = 2x - (y - 2c)$ and $B = (2x - y) - 2c$, then $A - B =$

- $-2y$
- $-4c$

- 0
- $2y$
- $4c$

5 of 10

A merchant sells three different sizes of canned tomatoes. A large can costs the same as 5 medium cans or 7 small cans. If a customer buys an equal number of small and large cans of tomatoes for the same amount of money needed to buy 200 medium cans, how many small cans does she buy?

- 35
- 45
- 72
- 199

6 of 10

If $6k - 5l > 27$ and $3l - 2k < -13$ and $5k - 5l > j$, what is the value of j ?

Click on the answer box and type in a number.

Backspace to erase.

7 of 10

When the integer a is multiplied by 3, the result is 4 less than 6 times the integer b . Therefore, what is $a - 2b$?

○ -12

○ $-\frac{4}{3}$

- $-\frac{3}{4}$
- $\frac{4}{3}$
- 12

[8](#) of 10

A bookstore will only order books that come in cases. Each case has 150 books in it and costs \$1,757.

Quantity A

The number of books that can be ordered for \$10,550

Quantity B

The number of books that can be ordered for \$12,290

- Quantity A is greater.
- Quantity B is greater.

- The two quantities are equal.
- The relationship cannot be determined from the information given.

9 of 10

If the product of two distinct integers is 91, which of the following could represent the sum of those two integers?

Indicate all possible values.

- 92
- 91
- 7
- 13
- 20

10 of 10

If $x = 3a$ and $y = 9b$, then all of the following are equal to $2(x + y)$ EXCEPT

- $3(2a + 6b)$
- $6(a + 3b)$
- $24\left(\frac{1}{4}a + \frac{3}{4}b\right)$
- $\frac{1}{3}(18a + 54b)$
- $12\left(\frac{1}{2}a + \frac{3}{4}b\right)$

Summary

- Digits are the numbers that make up other numbers. Numbers include whole numbers, fractions, negative numbers, and weird values like the square root of 2. Integers are numbers with no decimal or fractional part.
- Positive numbers are greater than zero and negative numbers less than zero. The number zero is neither positive nor negative.
- Even numbers are divisible by 2; odd numbers aren't. Only integers can be even or odd.

- A factor divides evenly into an integer. A multiple is an integer that a certain integer is a factor of. Every positive integer is a factor and a multiple of itself.
- The order of operations is PEMDAS.
- An exponent is shorthand for repeated multiplication. When in doubt on exponent problems, expand them out.
- The golden rule of equations: Whatever you do to one side of the equation, you must do to the other.
- With inequalities you have to flip the sign when you multiply or divide by a negative number.
- In order to solve an equation with two variables, you need two

equations. Stack them up and add or subtract to cancel out one of the variables.

- Use the FOIL process to expand quadratics. To solve a quadratic equation, set it equal to zero and factor.
- Plugging In converts algebra problems to arithmetic problems. Plug In by replacing variables in the question with real numbers or by working backwards from the answer choices provided.
- Use the FROZEN numbers on tricky quant comp questions with variables.

Chapter 11

Real World Math

Real world math is our title for the grab bag of math topics that will be heavily tested on the GRE. This chapter details a number of important math concepts, many of which you've probably used at one point or another in your daily adventures, even if you didn't recognize them. After completing this chapter, you'll have brushed up on important topics such as fractions, percents, ratios, proportions, and average. You'll also learn some important Princeton Review methods for organizing your work and efficiently and accurately answering questions on these topics.

EVERYDAY MATH

A few years ago when ETS reconfigured the GRE, they wanted the Math section test more of what they call “real life” scenarios that a typical graduate student might see. You can therefore expect the math questions on the GRE to heavily test topics such as fractions, percents, proportions, averages, and ratios—mathematical concepts that are theoretically part of your everyday life. Regardless of whether that’s true of your daily life or not, you’ll have to master these concepts in order to do well on the GRE Math section.

The math on the GRE is supposed to reflect the math you use in your day-to-day activities.

FRACTIONS, DECIMALS, AND PERCENTAGES

In the previous chapter we spent most of our time working with integers. Now we'll expand our discussion to include concepts like fractions, decimals, and percentages—all of which will appear frequently on the GRE.

Fractions

A **fraction** expresses the number of parts out of a whole. In the fraction $\frac{2}{3}$, for instance, the top part, or **numerator**, tells us that we have 2 parts, while the bottom part of the fraction, the **denominator**, indicates that

the whole, or total, consists of 3 parts. We use fractions whenever we're dealing with a quantity that's less than one.

Notice that the fraction bar is simply another way of expressing division. Thus, the fraction $\frac{2}{3}$ is just expressing the idea of “2 divided by 3.”

Fractions are important on the GRE. Make sure you're comfortable with them.

Reducing and Expanding Fractions

Fractions express a relationship between numbers, not actual amounts. For example, saying that you did $\frac{1}{2}$ of your homework expresses the same idea whether you had 10 pages of homework to do and you've done 5, or you had 50 pages to do and you've done 25 pages. This concept is important because on the GRE you'll frequently have to reduce or expand fractions.

To reduce a fraction, simply express the numerator and denominator as the products of their factors. Then cross out, or “cancel,”

factors that are common to both the numerator and denominator. Here's an example:

$$\frac{16}{20} = \frac{2 \times 2 \times 2 \times 2}{2 \times 2 \times 5} = \frac{\cancel{2} \times \cancel{2} \times 2 \times 2}{\cancel{2} \times \cancel{2} \times 5} = \frac{2 \times 2}{5} = \frac{4}{5}$$

You can achieve the same result by dividing the numerator and denominator by the factors that are common to both. In the example you just saw, you might realize that 4 is a factor of both the numerator and the denominator. That is, both the numerator and the denominator can be divided evenly (without a remainder) by 4. Doing this yields the much more manageable fraction $\frac{4}{5}$.

When you confront GRE math problems that involve big fractions, always reduce them before doing anything else.

Remember: You can only reduce across a multiplication sign.

Look at each of the following fractions:

$$\frac{1}{4} \quad \frac{2}{8} \quad \frac{6}{24} \quad \frac{18}{72} \quad \frac{90}{360} \quad \frac{236}{944}$$

What do you notice about each of these fractions? They all express the same information! Each of these fractions expresses the relationship of “1 part out of 4 total parts.”

Why Bother?

You may be wondering why, if the GRE allows the use of a calculator, you should bother learning how to add or subtract fractions or to reduce them or even know any of the topics covered in the next few pages. While it's true that you can use a calculator for these tasks, for many problems it's actually slower to do the math with the calculator than without. Scoring well on the GRE Math section requires a fairly strong grasp of the basic relationships among numbers, fractions, percents, and so on, so it's in your best interest to really understand these concepts rather than to rely on your calculator to get you through the day. In fact, if you put in the work now, you'll be surprised at how easy some of the problems become, especially when you don't have to refer constantly to the calculator to perform basic operations.

Adding and Subtracting Fractions

Adding and subtracting fractions that have a common denominator is easy—you just add the numerators and put the sum over the common denominator. Here's an example:

$$\frac{1}{10} + \frac{2}{10} + \frac{4}{10} =$$

$$\frac{1+2+4}{10} = \frac{7}{10}$$

In order to add or subtract fractions that have different denominators, you need to start by finding a common denominator. You may remember your teachers from grade school imploring you to find the “lowest common denominator.” Actually, any common denominator will do, so find whichever one you find most comfortable working with.

$$\frac{7}{8} - \frac{5}{12} = \frac{21}{24} - \frac{10}{24} = \frac{11}{24}$$

Here, we expanded the fraction $\frac{7}{8}$ into the equivalent fraction $\frac{21}{24}$ by multiplying both the numerator and denominator by 3. Similarly, we converted $\frac{5}{12}$ to $\frac{10}{24}$ by multiplying both denominator and numerator by 2. This left us with two fractions that had the same denominator, which meant that we could simply subtract their numerators.

When adding and subtracting fractions, you can also use a technique we call the Bowtie. The Bowtie method accomplishes exactly what we just did in one fell swoop. To use the Bowtie, first multiply the denominators of each fraction. This gives you a common denominator. Then multiply the denominator

of each fraction by the numerator of the other fraction. Take these numbers and add or subtract them—depending on what the question asks you to do—to get the numerator of the answer. Then reduce if necessary.

$$\frac{2}{3} + \frac{3}{4} =$$

$$\frac{2}{3} \times \frac{3}{4} = \frac{8}{12} + \frac{9}{12} = \frac{17}{12}$$

and

$$\frac{2}{3} - \frac{3}{4} =$$

$$\frac{2}{3} \times \frac{3}{4} = \frac{8}{12} - \frac{9}{12} = -\frac{1}{12}$$



The Bowtie method is a convenient shortcut to use

when you're adding and subtracting fractions.

Multiplying Fractions

There's nothing tricky about multiplying fractions: All you do is multiply straight across—multiply the first numerator by the second numerator and the first denominator by the second denominator. Here's an example:

$$\frac{4}{5} \times \frac{10}{12} = \frac{40}{60} = \frac{2}{3}$$

When multiplying fractions, you can make your life easier by reducing before you multiply. Do this once again by dividing out common factors.

$$\frac{4}{5} \times \frac{10}{12} = \frac{4}{5} \times \frac{5}{6} = \frac{20}{30} = \frac{2}{3}$$

Multiplying fractions is a snap: Just multiply

straight across, numerator
times numerator and
denominator times
denominator.

Also remember that when you're multiplying fractions, you can even reduce diagonally; as long as you're working with a numerator and a denominator of opposite fractions, they don't have to be in the same fraction. So you end up with

$$\frac{4}{5} \times \frac{5}{6} = \frac{2}{1} \times \frac{1}{3} = \frac{2}{3}$$

Of course, you get the same answer no matter what method you use, so attack fractions in whatever fashion you find easiest.

Dividing Fractions

Dividing fractions is just like multiplying fractions, with one crucial difference: Before you multiply, you have to turn the second

fraction upside down (that is, put its denominator over its numerator, or to use fancy math lingo, find its reciprocal). In some cases, you can also reduce before you multiply. Here's an example:

$$\frac{2}{3} \div \frac{4}{5} = \frac{2}{3} \times \frac{5}{4} = \frac{1}{3} \times \frac{5}{2} = \frac{5}{6}$$

ETS sometimes gives you problems that involve fractions which have numerators or denominators that are themselves fractions. These problems might look intimidating, but if you're careful, you won't have any trouble with them. All you have to do is remember what we said about a fraction being shorthand for division. Always rewrite the expression horizontally. Here's an example:

$$\frac{\frac{7}{1}}{\frac{1}{4}} = 7 \div \frac{1}{4} = \frac{7}{1} \times \frac{4}{1} = \frac{28}{1} = 28$$

Comparing Fractions

The GRE might also present you with math problems that require that you to compare two fractions and decide which is larger, especially on quant comp questions. There are a couple of ways to accomplish this. One is to find equivalent fractions that have a common denominator. This works with simpler fractions, but on some problems the common denominator might be hard to find or hard to work with.

As an alternative, you can use a variant of the Bowtie technique. In this variant, you don't have to multiply the denominators, just the denominators and the numerators. The fraction with the larger product in its numerator is the greater fraction. Let's say we had to compare the following fractions:

$$\frac{3}{7} \quad \frac{7}{12}$$

$$\begin{array}{ccc} 36 & & 49 \\ \frac{3}{7} & \begin{array}{c} \swarrow \quad \searrow \\ \nwarrow \quad \swarrow \end{array} & \frac{7}{12} \end{array}$$

Multiplying the first denominator by the second numerator gives you 49. This means the numerator of the second fraction $\left(\frac{7}{12}\right)$ is 49. Multiplying the second denominator by the first numerator gives you 36, which means the first fraction has a numerator of 36. Since 49 is greater than 36, $\frac{7}{12}$ is greater than $\frac{3}{7}$. Remember that when you use this method, it's the numerators that matter.

788/1807
You can also use the calculator feature to change the fractions into decimals.

Comparing More Than Two Fractions

You may also be asked to compare more than two fractions. On these types of problems, don't waste time trying to find a common denominator for all of them. Simply use the Bowtie to compare two of the fractions at a time.

Here's an example:



Which of the following statements is true?

- $\frac{3}{8} < \frac{2}{9} < \frac{4}{11}$
- $\frac{2}{5} < \frac{3}{7} < \frac{4}{13}$
- $\frac{4}{13} < \frac{2}{5} < \frac{3}{7}$
- $\frac{3}{7} < \frac{3}{8} < \frac{2}{5}$
- $\frac{2}{9} < \frac{3}{7} < \frac{3}{8}$

Here's How to Crack It

As you can see, it would be a nightmare to try to find common denominators for all these fractions, so instead we'll use the Bowtie method. Simply multiply the denominators and numerators of a pair of fractions and note the results. For example, to check answer choice (A), we first multiply 8 and 2,

which gives us a numerator of 16 for the fraction $\frac{2}{9}$. But multiplying 9 and 3 gives us a nu-

merator of 27 for the first fraction. This means that $\frac{3}{8}$ is greater than $\frac{2}{9}$, and we can

eliminate choice (A), because the first part of it is wrong. Here's how the rest of the choices shape up:

- $\frac{2}{5} < \frac{3}{7} < \frac{4}{13}$ Compare $\frac{3}{7}$ and $\frac{4}{13}$; $\frac{3}{7}$ is larger. Eliminate (B).
- $\frac{4}{13} < \frac{2}{5} < \frac{3}{7}$ These fractions are in order.
- $\frac{3}{7} < \frac{3}{8} < \frac{2}{5}$ $\frac{3}{7}$ is larger than $\frac{3}{8}$. Eliminate (D).
- $\frac{2}{9} < \frac{3}{7} < \frac{3}{8}$ $\frac{3}{7}$ is larger than $\frac{3}{8}$. Eliminate (E).

The answer is choice (C). Make sure you are doing all of this work in an organized fashion on your scratch paper.

Converting Mixed Numbers into Fractions

A **mixed number** is a number that is represented as an integer and a fraction, such as $2\frac{2}{3}$. In most cases on the GRE, you should get rid of mixed fractions by converting them to improper fractions. How do you do this? By multiplying the denominator of the fraction by the integer, then adding that result to the numerator, and then putting the whole

thing over the denominator. In other words,
for the fraction above we would get $\frac{3 \times 2 + 2}{3}$
or $\frac{8}{3}$.

Improper fractions have a numerator that is greater than the denominator. When you convert mixed numbers, you'll get an improper fraction as the result.

The result, $\frac{8}{3}$, is equivalent to $2\frac{2}{3}$. The only difference is that $\frac{8}{3}$ is easier to work with in math problems. Also, answer choices are usually not given in the form of mixed numbers.

Decimals

Decimals are just fractions in disguise.

Basically, decimals and fractions are two different ways of expressing the same thing.

Every decimal can be written as a fraction, and every fraction can be written as a decimal.

For example, the decimal 0.35 can be written as the fraction $\frac{35}{100}$: These two numbers,

0.35 and $\frac{35}{100}$, have the same value.

To turn a fraction into its decimal equivalent, all you have to do is divide the numerator by

the denominator. Here, for example, is how you would find the decimal equivalent of $\frac{3}{4}$:

$$\frac{3}{4} = 3 \div 4 = 4 \overline{)3.00}^{0.75}$$

Try this problem:



$$7 < x < 8$$

$$y = 9$$

Quantity A

$$\frac{x}{y}$$

Quantity B

$$0.85$$

- Quantity A is greater.
- Quantity B is greater.
- The two quantities are equal.

- The relationship cannot be determined from the information given.

Here's How to Crack It

So, you're sitting at your cubicle at the Prometric testing center and this problem pops up. What do you see? Before we even talk about fractions, the first thing you should note is that this is a quant comp with variables. Set up your scratch paper. It should look like this:

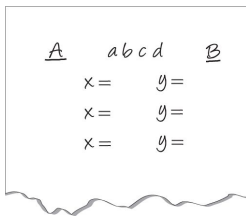

Now they've told us that x is going to be seven point something. Try Plugging In the smallest value you can think of for x . Write down $x = 7.1$ and $y = 9$. The value in Quantity A is 0.79. The value in Quantity B is 0.85. Quantity B is greater, so eliminate choices (A) and (C). Now try making x as big as you can make it. Write down $x = 7.9$ and $y = 9$. The value in column A is 0.88 and the value in Quantity B is 0.85. Quantity A is greater so eliminate choice B, and you're done. The answer is (D).

Your scratch paper should look like this:

<u>A</u>	x	y	<u>B</u>
0.79	$x = 7.1$	$y = 9$	0.85
0.88	$x = 7.9$	$y = 9$	0.85
	$x =$	$y =$	

Comparing Decimals

Which is greater: 0.00099 or 0.001? ETS loves this sort of problem. You'll never go wrong, though, if you follow these easy steps.

- Line up the numbers by their decimal points.
- Fill in the missing zeros.

Here's how to answer the question we just asked. First, line up the two numbers by their decimal points.

$$\begin{array}{r} 0.00099 \\ 0.001 \end{array}$$

Now fill in the missing zeros.

$$\begin{array}{r} 0.00099 \\ 0.00100 \end{array}$$

Can you tell which number is greater? Of course you can. 0.00100 is greater than 0.00099 , because 100 is greater than 99 .

Digits and Decimals

Remember our discussion about digits, earlier? Well, sometimes the GRE will ask you questions about digits that fall after the decimal point as well. Suppose you have the number 0.584 .

- 0 is the units digit.
- 5 is the tenths digit.
- 8 is the hundredths digit.
- 4 is the thousandths digit.

Percentages

The final member of our numbers family is percentages. A **percentage** is just a special

type of fraction, one that always has 100 as the denominator. Percent literally means “per 100” or “out of 100” or “divided by 100.”

If your best friend finds a dollar and gives you 50¢, your friend has given you 50¢ out of 100, or $\frac{50}{100}$ of a dollar, or 50 percent of the dollar. To convert fractions to percentages, just expand the fraction so it has a denominator of 100:

$$\frac{3}{5} = \frac{60}{100} = 60\%$$



Another way to convert a fraction into a percentage is to divide the numerator by the denominator and multiply the result by 100. So, $\frac{3}{5} = 3 \div 5 = 0.6 \times 100 = 60\%$.

For the GRE, you should memorize the following percentage-decimal-fraction equivalents. Use these friendly fractions and percentages to eliminate answer choices that are way out of the ballpark.

$$0.01 = \frac{1}{100} = 1\%$$

$$0.1 = \frac{1}{10} = 10\%$$

$$0.666\dots = \frac{2}{3} = 66\frac{2}{3}\%$$

$$0.2 = \frac{1}{5} = 20\%$$

$$0.25 = \frac{1}{4} = 25\%$$

$$0.8 = \frac{4}{5} = 80\%$$

$$0.333\dots = \frac{1}{3} = 33\frac{1}{3}\%$$

$$0.4 = \frac{2}{5} = 40\%$$

$$2.0 = \frac{2}{1} = 200\%$$

$$0.75 = \frac{3}{4} = 75\%$$

$$0.5 = \frac{1}{2} = 50\%$$

$$0.6 = \frac{3}{5} = 60\%$$

$$1.0 = \frac{1}{1} = 100\%$$

Converting Decimals to Percentages

In order to convert decimals to percentages, just move the decimal point two places to the right. For example, 0.8 turns into 80 percent, 0.25 into 25 percent, 0.5 into 50 percent, and 1 into 100 percent.

Translation

One of the best ways to handle percentages in word problems is to know how to translate them into an equation that you can manipulate. Use the following table to help you translate percentage word problems into equations you can work with.

Word	Equivalent Symbol
percent	$\frac{\quad}{100}$
is	=
of, times, product	\times
what (or any unknown value)	any variable (x, k, b)

These translations apply to any word problem, not just percent problems.

Here's an example:

56 is what percent of 80 ?

- 66%
- 70%
- 75%
- 80%
- 142%

Here's How to Crack It

To solve this problem, let's translate the question and then solve for the variable. So, "56 is what percent of 80," in math speak, is equal to

$$56 = \frac{x}{100}(80)$$

$$56 = \frac{80x}{100}$$

Don't forget to reduce the fraction: $56 = \frac{4}{5}x$.

Now multiply both sides of the equation by the reciprocal, $\frac{5}{4}$.

Don't forget to reduce again before you calculate:

$$\begin{aligned}\left(\frac{5}{4}\right)\left(\frac{56}{1}\right) &= \left(\frac{5}{4}\right)\left(\frac{4x}{5}\right) \\ (5)(14) &= x \\ 70 &= x\end{aligned}$$

That's answer choice (B). Did you notice choice (E)? Because 56 is less than 80, the answer would have to be less than 100 percent, so 142 percent is way too big, and you could have eliminated it from the get-go by Ballparking.

Let's try a quant comp example.

5 is r percent of 25

s is 25 percent of 60

Quantity A

Quantity B

r

s

- Quantity A is greater.
- Quantity B is greater.
- The two quantities are equal.
- The relationship cannot be determined from the information given.

Here's How to Crack It

First translate the first statement.

$$5 = \frac{r}{100} (25)$$

$$5 = \frac{25r}{100}$$

$$5 = \frac{r}{4}$$

$$(4)(5) = \left(\frac{r}{4}\right)(4)$$

$$20 = r$$

That takes care of Quantity A. Now translate the second statement.

$$s = \frac{25}{100} (60)$$

$$s = \frac{1}{4} (60)$$

$$s = 15$$

That takes care of Quantity B. The answer is (A).



Percentage Increase/ Decrease

To find the percentage by which something has increased or decreased, use the following formula.

On percent increase problems, the original is always the smaller number.

On percent decrease problems, the original is the larger number.

$$\text{Percent Change} = \frac{\text{Difference}}{\text{Original}} \times 100$$

The “difference” is simply what you get when you subtract the smaller number from the larger number. The “original” is whichever number you started with. If the question

asks you to find a **percent increase**, then the original number is the **smaller number**. If the question asks you to find a **percent decrease**, then the original number is the **larger number**.

On the GRE, a percent change will not be stated as a negative number. Instead, the problem will ask for a percent decrease. So, if something declined by 50%, the problem will ask for a percent decrease and the answer will be stated as 50%. Note that when you use the percent change formula, you always subtract the smaller number from the larger number to find the difference. Doing so ensures that you get a positive result.

Here's an example.

What number goes on the bottom of the fraction?



Vandelay Industries reported a \$6,000 profit over the three-month period from March to May of the current year. Over the previous three month period, if Vandelay Industries realized a \$3,500 profit, by approximately what percent did its profit increase?

- 25%
- 32%
- 42%
- 55%
- 70%

Here's How to Crack It

Let's use the percent change formula we just learned. The first step is to find the difference between the two numbers. The initial

profit was \$3,500 and the final profit is \$6,000. The difference between these two numbers is $6,000 - 3,500 = 2,500$. Next, we need to divide this number by the original, or starting, value.

One way to help you figure out what value to use as the original value is to check to see whether you're dealing with a percent increase or a percent decrease question. Remember that on a percent increase question, you should always use the smaller of the two numbers as the denominator and that on percent decrease you need to use the larger of the two numbers as the denominator. Because here we want to find the percent

increase, the number we want to use for our denominator is 3,500. So our percent increase fraction looks like this: $\frac{2,500}{3,500}$. We can reduce this to $\frac{25}{35}$ by dividing by 100, and reduce even further by dividing by 5. This leaves us with $\frac{5}{7}$, which is approximately 70% (remember that the fraction bar means divide, so if you divide 5 by 7, you'll get 0.71). Thus, choice (E) is the answer.



Here's another question.



Model	Original Price	Sale Price
A	\$12,000	\$9,500
B	\$16,000	\$13,000
C	\$10,000	\$7,500
D	\$17,500	\$13,000
E	\$20,000	\$15,500
F	\$22,000	\$16,000

The table above shows the original price and the sale price for six different models of cars. For which car models is the discount between the original price and the sale price at least 25%?

Indicate all such models.

A

B

C

D

E

F

Here's How to Crack It

First list A, B, C, D, E, and F in a column on your scratch paper. You are asked to identify a 25% change or greater between the two prices. You know the formula for this. It is $\text{percent change} = \frac{\text{difference}}{\text{original}} \times 100$. Using the calculator, subtract 9,500 from 12,000 to get 2,500. This is the difference. Divide it by the original, 12,000, to get 0.2, which when multiplied by 100 is 20%. Since 20% is less than

25%, cross it off on your scratch paper. Try the next one. $16,000 - 13,000 = 3,000$. Divide by 16,000. Too small. Cross it off. Repeat this process for each of the answer choices. Choices (C), (D), and (F) all work.



PLUGGING IN ON FRACTION AND PERCENT PROBLEMS

Now that you've become familiar with fractions and percents, we'll show you a great method for solving many of these problems. When you come to regular multiple-choice questions, or multiple choice, multiple answers, that involve fractions or percents, you can simply Plug In a number and work through the problem using that number. This approach works even when the problem doesn't have variables in it. Why? Because, as you know, fractions and percents express only a relationship between numbers—the actual numbers don't matter. For example, look at the following problem:

Plugging In on fraction and percent problems is

a great way to make your
life easier.

A recent survey of registered voters in City X found that $\frac{1}{3}$ of the respondents support the mayor's property tax plan. Of those who did not support the mayor's plan, $\frac{1}{8}$ indicated they would not vote to reelect the mayor if the plan were implemented. Of all the respondents, what fraction indicated that they would

not vote for the mayor if the plan
were enacted?

$\frac{1}{16}$

$\frac{1}{12}$

$\frac{1}{6}$

$\frac{1}{3}$

$\frac{2}{3}$

What important information
is missing from the
problem?

Here's How to Crack It

Even though there are no variables in this problem, we can still Plug In. On fraction and percent problems, ETS will often leave out one key piece of information: the total. Plugging In for that missing value will make your life much easier. What crucial information did ETS leave out of this problem? The total number of respondents. So let's Plug In a value for it. Let's say that there were 24 respondents to the survey. 24 is a good number to use because we'll have to work with $\frac{1}{3}$ and $\frac{1}{8}$, so we want a number that's divisible

by both those fractions. Working through the problem with our number, we see that $\frac{1}{3}$ of the respondents support the plan. $\frac{1}{3}$ of 24 is 8, so that means 16 people do not support the plan. Next, the problem says that $\frac{1}{8}$ of those who do not support the plan will not vote for the mayor. $\frac{1}{8}$ of 16 is 2, so 2 people won't vote for the mayor. Now we just have to answer the question: Of all respondents, how many will not vote for the mayor? Well, there were 24 total respondents and we

figured out that 2 aren't voting. So that's $\frac{2}{24}$,
or $\frac{1}{12}$. Answer choice (B) is the one we want.



RATIOS AND PROPORTIONS

If you're comfortable working with fractions and percentages, you'll be comfortable working with ratios and proportions, because ratios and proportions are simply special types of fractions. Don't let them make you nervous. Let's look at ratios first and then we'll deal with proportions.

What Is a Ratio?

Recall that a fraction expresses the relationship of a part to the whole. A **ratio** expresses a different relationship: part to part. Imagine yourself at a party with 8 women and 10 men

in attendance. Remembering that a fraction expresses a part-to-whole relationship, what fraction of the partygoers are female? $\frac{8}{18}$, or 8 women out of a total of 18 people at the party. But what's the ratio, which expresses a part to part relationship, of women to men? $\frac{8}{10}$, or as ratios are more commonly expressed, 8 : 10. You can reduce this ratio to 4 : 5, just like you would a fraction.

A ratio is just another type of fraction.

On the GRE, you may see ratios expressed in several different ways:

$x : y$
the ratio of x to y
 x is to y

In each case, the ratio is telling us the relationship between parts of a whole.

Every Fraction Can Be a Ratio, and Vice Versa

Every ratio can be expressed as a fraction. A ratio of $1 : 2$ means that the total of all the parts is either 3 or a multiple of 3. So, the ratio $1 : 2$ can be expressed as the fraction $\frac{1}{3}$.

Likewise, the fraction $\frac{1}{3}$ means that we are looking at one part out of a total of three so

the other part must be 2. That means that the ratio is 1 : 2.

Treat a Ratio Like a Fraction

Anything you can do to a fraction you can also do to a ratio. You can cross-multiply, find common denominators, reduce, and so on.

Find the Total

The key to dealing with ratio questions is to find the whole, or the total. Remember: A ratio tells us only about the parts, not the total. In order to find the total, add the numbers in the ratio. A ratio of 2 : 1 means that there are three total parts. A ratio of 2 : 5 means that we're talking about a total of 7 parts. And a ratio of 2 : 5 : 7 means there are 14 total

parts. Once you have a total you can start to do some fun things with ratios.

For example, let's say you have a handful of pennies and nickels. If you have 30 total coins and the pennies and nickels are in a 2 : 1 ratio, how many pennies do you have? The total for our ratio is 3, meaning that out of every 3 coins, there are 2 pennies and 1 nickel. So if there are 30 total coins, there must be 20 pennies and 10 nickels. Notice that $\frac{20}{10}$ is the same as $\frac{2}{1}$, is the same as 2 : 1!

Like a fraction, a ratio expresses a relationship between numbers.

When you are working with ratios, there's an easy way not only to keep track of the numbers in the problem but also to quickly figure out the values in the problem. It's called the Ratio Box. Let's try the same question, but with some different numbers; if you have 24 coins in your pocket and the ratio of pennies to nickels is 2 : 1, how many pennies and nickels are there? The Ratio Box for this question is below, with all of the information we're given already filled in.

	Pennies	Nickels	Total
ratio	2	1	3
multiply by			
actual numbers			24

The minute you see the word "ratio," draw a ratio box on your scratch paper.

Remember that ratios are relationships between numbers, not actual numbers, so

the real total is 24; that is, you have 24 actual coins in your pocket. The ratio total (the number you get when you add the number of parts in the ratio) is 3.

The middle row of the table is for the multiplier. How do you get from 3 to 24? You multiply by 8. Remember when we talked about finding equivalent fractions? All we did was multiply the numerator and denominator by the same value. That's exactly what we're going to do with ratios. This is what the ratio box looks like now:

	Pennies	Nickels	Total
ratio	2	1	3
multiply by	8	8	8
actual numbers			24

The multiplier is the key concept in working with ratios. Just remember that whatever you multiply one

part by, you must multiply every part by.

Now let's finish filling in the box by multiplying everything else.

	Pennies	Nickels	Total
ratio	2	1	3
multiply by	8	8	8
actual numbers	16	8	24

Therefore, of the 24 coins 16 are pennies and 8 are nickels.

Let's try a GRE example.

Flour, eggs, yeast, and salt are mixed by weight in the ratio of 11 : 9 : 3 : 2, respectively. How many pounds of yeast are there in 20 pounds of the mixture?

- $1\frac{3}{5}$
- $1\frac{4}{5}$
- 2
- $2\frac{2}{5}$
- $8\frac{4}{5}$



**Need More Math
Review?**

Check out *Math Workout*
for the GRE. If you're in
a hurry, pick up *Crash
Course* for the GRE.

Here's How to Crack It

The minute you see the word *ratio*, draw a ratio box on your scratch paper and fill in what you know.

	Flour	Eggs	Yeast	Salt	Total
ratio	11	9	3	2	
multiply by					
actual numbers					20

First, add all of the numbers in the ratio to get the ratio total.

	Flour	Eggs	Yeast	Salt	Total
ratio	11	9	3	2	25
multiply by					
actual numbers					20

Now, what do we multiply 25 by to get 20?

$$25x = 20$$

$$\frac{25x}{25} = \frac{20}{25}$$

$$x = \frac{20}{25}$$

$$x = \frac{4}{5}$$

So $\frac{4}{5}$ is our “multiply by” number. Let’s fill it in.

	Flour	Eggs	Yeast	Salt	Total
ratio	11	9	3	2	25
multiply by	$\frac{4}{5}$	$\frac{4}{5}$	$\frac{4}{5}$	$\frac{4}{5}$	$\frac{4}{5}$
actual numbers					20

The question asks for the amount of yeast, so we don’t have to worry about the other ingredients. Just look at the yeast column. All

we have to do is multiply 3 by $\frac{4}{5}$ and we have our answer: $3 \times \frac{4}{5} = \frac{12}{5} = 2\frac{2}{5}$, which is answer choice (D).

What Is a Proportion?

So you know that a fraction is a relationship between part and whole, and that a ratio is a relationship between part and part. A **proportion** is an equivalent relationship between two fractions or ratios. Thus, $\frac{1}{2}$ and $\frac{4}{8}$ are proportionate because they are

equivalent fractions. But $\frac{1}{2}$ and $\frac{2}{3}$ are not in proportion because they are not equal ratios.

The GRE often contains problems in which you are given two proportional, or equal, ratios from which one piece of information is missing. These questions take a relationship or ratio, and project it onto a larger or smaller scale. Proportion problems are recognizable because they always give you three values and ask for a fourth value. Here's an example:

The key to proportions is setting them up correctly.

If the cost of a one-hour telephone call is \$7.20, what would be the cost

in dollars of a 10-minute telephone call at the same rate?

 dollars

Click on the answer box and type in a number.

Backspace to erase.

Here's How to Crack It

It's very important to set up proportion problems correctly. That means placing your information on your scratch paper. Be especially careful to label *everything*. It takes only an extra two or three seconds, but doing this will help you catch lots of errors.

Relationship Review

You may have noticed a trend in the preceding pages. Each of the major topics covered—fractions, percents, ratios, and proportions—described a particular relationship between numbers. Let's review:

- A fraction expresses the relationship between a part and the whole.
- A percent is a special type of fraction, one that expresses the relationship of part to whole as a fraction with the number 100 in the denominator.
- A ratio expresses the relationship between part and part. Adding the parts of a ratio gives you the whole.

- A proportion expresses the relationship between equal fractions, percents, or ratios.
- Each of these relationships shares all the characteristics of a fraction. You can reduce them, expand them, multiply them, and divide them using the exact same rules you used for working with fractions.

For this question, let's express the ratios as dollars over minutes, because we're being asked to find the cost of a 10-minute call. That means that we have to convert 1 hour to 60 minutes (otherwise it wouldn't be a proportion).

$$\frac{\$}{\text{min}} = \frac{\$7.20}{60} = \frac{x}{10}$$

Now cross-multiply.

$$60x = (7.20)(10)$$

$$60x = 72$$

$$\frac{60x}{60} = \frac{72}{60}$$

$$x = \frac{6}{5}$$

Now we can enter 1.20 into the box.



AVERAGES

The **average** (arithmetic mean) of a list of numbers is the sum, or total value, of all the numbers in the list divided by the number of numbers in the list. The average of the list 1, 2, 3, 4, 5 is equal to the total of the numbers ($1 + 2 + 3 + 4 + 5$, or 15) divided by the number of numbers in the list (which is 5). Dividing 15 by 5 gives us 3, so 3 is the average of the list.

GRE average problems
always give you two of
the three numbers needed.

ETS always refers to an average as an “average (arithmetic mean).” This confusing parenthetical remark is meant to keep you from being confused by other more obscure kinds of averages, such as geometric and harmonic means. You’ll be less confused if you simply

ignore the parenthetical remark and know that average means total of the elements divided by the number of elements.

Think Total

Don't try to solve average problems all at once. Do them piece by piece. The key formula to keep in mind when doing problems that involve averages is

$$\text{Average} = \frac{\text{Total}}{\# \text{ of things}}$$

The minute you see the word *average*, draw an average pie on your scratch paper.

Drawing an Average Pie will help you organize your information.

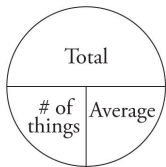

Here's how the Average Pie works. The *total* is the sum of the numbers being averaged. The *number of things* is the number of different elements that you are averaging. And the *average* is, naturally, the average.

Say you wanted to find the average of 4, 7, and 13. You would add those numbers to get the total and divide that total by three.

$$\begin{aligned}4 + 7 + 13 &= 24 \\ \frac{24}{3} &= 8\end{aligned}$$

Mathematically, the Average Pie works like this:

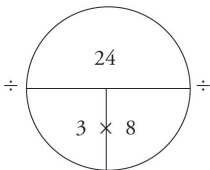

Which two pieces of the pie do you have?

The horizontal bar is a division bar. If you divide the *total* by the *number of things*, you get the *average*. If you divide the total by the *average*, you get the *number of things*. If you have the *number of things* and the *average*, you can simply multiply them together to find the *total*. This is one of the most important things you need to be able to do to solve GRE average problems.

Using the Average Pie has several benefits. First, it's an easy way to organize information. Furthermore, the Average Pie makes it clear that if you have two of the three pieces, you can always find the third. This makes it easier to figure out how to approach the problem. If you fill in the number of things, for example, and the question wants to know the average, the Average Pie shows you that the key to unlocking that problem is finding the total.

Try this one.

The average (arithmetic mean) of seven numbers is 9 and the average of three of these numbers is 5. What is the average of the other four numbers?

- 4
- 5
- 7
- 10
- 12

Draw a new average pie each time you encounter the word *average* in a question.

Here's How to Crack It

Let's take the first sentence. You have the word *average*, so draw an average pie and fill in what you know. We have seven numbers with an average of 9, so plug those values into the Average Pie and multiply to find the total.

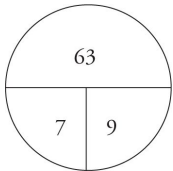

Now we also know that three of the numbers have an average of 5, so draw another Average Pie, plug those values into their places, and multiply to find the total of those three numbers.

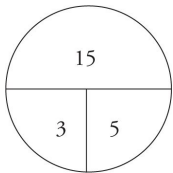

The question is asking for the average of the four remaining numbers. Draw one more Average Pie and Plug In 4 for the number of things.

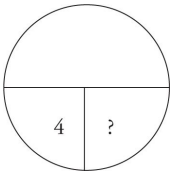

In order to solve for the average, we need to know the total of those four numbers. How do we find this? From our first Average Pie we know that the total of all seven numbers is 63. The second Average Pie tells us that the total of three of those numbers was 15. Thus, the total of the remaining four has to be $63 - 15$, which is 48. Plug 48 into the last Average Pie, and divide by 4 to get the average of the four numbers.

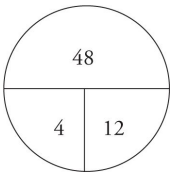

The average is 12, which is answer choice (E).



Let's try one more.



The average (arithmetic mean) of a set of 6 numbers is 28. If a certain number, y , is removed from the set, the average of the remaining numbers in the set is 24.

Quantity A

Quantity B

y

48

- Quantity A is greater.
- Quantity B is greater.
- The two quantities are equal.

- The relationship cannot be determined from the information given.

Here's How to Crack It

All right, let's attack this one. The problem says that the average of a set of six numbers is 28, so let's immediately draw an average pie and calculate the total.

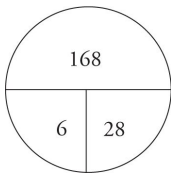

If a certain number, y , is removed from the set, there are now five numbers left. We already know that the new average is 24, so draw another Average Pie.

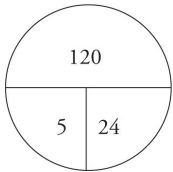

The difference between the totals must be equal to y . $168 - 120 = 48$. Thus, the two quantities are equal, and the answer is (C).



Up and Down

Averages are very predictable. You should make sure you automatically know what happens to them in certain situations. For example, suppose you take three tests and earn an average score of 90. Now you take a fourth test. What do you know?

If your average goes up as a result of the fourth score, then you know that your fourth

score was higher than 90. If your average stays the same as a result of the fourth score, then you know that your fourth score was exactly 90. If your average goes down as a result of the fourth score, then you know that your fourth score was less than 90.

MEDIAN, MODE, AND RANGE

The **median** is the middle value in a list of numbers; above and below the median lie an equal number of values. For example, in the list of numbers (1, 2, 3, 4, 5, 6, 7) the median is 4, because it's the middle number (and there are an odd number of numbers in the list). If the list contained an even number of integers such as (1, 2, 3, 4, 5, 6) the median is the average of 3 and 4, or 3.5. When looking for the median, sometimes you have to put the numbers in order yourself. What is the median of the list of numbers (13, 5, 6, 3, 19, 14, 8)? First, put the numbers in order from least to greatest, (3, 5, 6, 8, 13, 14, 19). Then take the middle number. The median is 8. Just think *median = middle* and always make sure the numbers are in order.

Don't confuse
median and mode!

The **mode** is the number in a list of numbers that occurs most frequently. For example, in the list (2, 3, 4, 5, 3, 8, 6, 9, 3, 9, 3) the mode is 3, because 3 shows up the most. Just think *mode = most*.

The minute you see the word *median* in a question, find a bunch of numbers and put them in order.

The **range** is the difference between the greatest and the least numbers in a list of numbers. So, in the list of numbers (2, 6, 13, 3, 15, 4, 9), the range is 15 (the greatest number in the list) - 2 (the least number in the list), or 13.

Here's an example:

$$\text{Set } F = \{4, 2, 7, 11, 8, 9\}$$

Quantity A

The range of Set
 F

Quantity B

The median of
Set F

- Quantity A is greater.
- Quantity B is greater.
- The two quantities are equal.
- The relationship cannot be determined from the information given.

What do we need to do to the numbers in this set?

Here's How to Crack It

Let's put the numbers in order first, so it'll be easier to see what we have: $\{2, 4, 7, 8, 9, 11\}$. First let's look at Quantity A: The range is

the greatest number, or 11, minus the least number, or 2. That's 9. Now let's look at Quantity B: The minute you see the word *median*, be sure to put the numbers in order. The median is the middle number of the set, but because there are two middle numbers, 7 and 8, we have to find the average. Or do we? Isn't the average of 7 and 8 clearly going to be smaller than the number in Quantity A, which is 9? Yes, in quant comp questions, we compare, not calculate. The answer is (A).



STANDARD DEVIATION

Standard deviation is one of those phrases that math people like to throw around to scare non-math people, but it's really not that scary. The GRE might ask you questions about standard deviation, but you'll never have to actually calculate it; instead, you'll just need a basic understanding of what standard deviation is. In order to understand standard deviation, we must first look at something all standardized testers should be familiar with, the bell curve.

You'll never have to calculate
the standard deviation
on the GRE.

Your Friend the Bell Curve

The first thing to know about a bell curve is that the number in the middle is the mean.



The minute you see the phrase “standard deviation” or “normal distribution,” draw a bell curve and fill in the percentages.

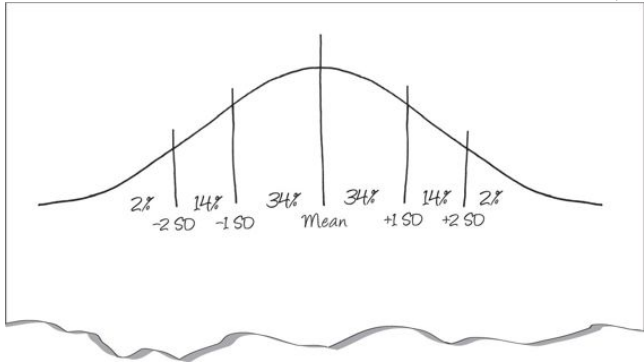

Imagine that 100 students take a test and the results follow a normal distribution. The minute you see the phrase “normal distribution,” draw a bell curve. Let’s say that the average score on this test is an 80. Put 80 in the middle of the curve. You know, however, that a few of those students were extremely well prepared and got a really high score, let’s say that 2% of them got a 96 or higher. Put a 96 above the right 2% line on the curve.

Standard deviation measures how much a score differs from the norm (the average) in even increments. The curve tells us that a score earned by only 2% of the students is two standard deviations from the norm. If the norm is 80 and 96 is two standard deviations away, then one standard deviation on this test is 8 points. Why? Remember that standard deviations are even increments. If the average is 80 and the score 2 standard deviations from the norm is 96, then the difference is 16. So, one standard deviation is half of that difference or 8. The score at 1 standard deviation greater than the norm is, therefore, 88. Two standard deviations above the norm is 96, while two standard deviations below the norm is 64. One standard deviation above the norm is 88, and one standard deviation below the norm is 72. Fill these in on your bell curve.

Now you know quite a bit about the distribution of scores on this test. 68 percent of the students received a score between 72 and 88. 98 percent scored above a 64. That's all there is to know about standard deviations. The percentages don't change, so memorize those. When you see the phrase, just draw a bell curve and fill in what you know. Here's what the curve looks like for this test:

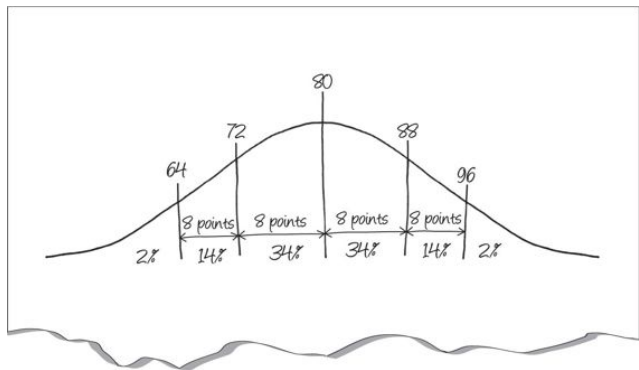

When it comes to standard deviation, the percentages don't change, so memorize those: 2, 14, and 34.

Here's an example of how ETS might test standard deviation:

Quantity A

The standard deviation of a list of data consisting of 10 integers ranging from -20 to -5

Quantity B

The standard deviation of a list of data consisting of 10 integers ranging from 5 to 20

- Quantity A is greater.
- Quantity B is greater.

- The two quantities are equal.
- The relationship cannot be determined from the information given.

Here's How to Crack It

ETS is hoping you'll make a couple of wrong turns on this problem. The first trap they set is that one list of numbers contains negative integers while the other doesn't—but this doesn't mean that one list has a negative standard deviation. Standard deviation is defined as the distance a point is from the mean, so it can never be negative. The second trap is that ETS hopes you'll waste a lot of time trying to calculate standard deviation based on the information given. But you know better than to try to do that. Remember that ETS won't ask you to calculate standard deviation; it's a complex

calculation. Plus, as you know, you need to know the mean in order to calculate the standard deviation and there's no way we can find it based on the information here. Thus, we have no way of comparing these two quantities, and our answer is (D).



Now let's try a question that will make use of the bell curve.



The fourth grade at School X is made up of 300 students who have a total weight of 21,600 pounds. If the weight of these fourth graders has a normal distribution and the standard deviation equals 12 pounds, approximately what percentage of the

fourth graders weighs more than 84 pounds?

- 12%
- 16%
- 36%
- 48%
- 60%

Here's How to Crack It

This one's a little tougher than the earlier standard deviation questions. The first step is to determine the average weight of the students, which is $\frac{21,600}{300} = 72$ pounds. If the standard deviation is 12 pounds, then 84

pounds places us exactly one standard deviation above the mean, or at the 84th percentile (remember the bell curve?). Because 16 percent of all students weigh more than 84 pounds, the answer is (B).



RATE

Rate problems are similar to average problems. A rate problem might ask for an average speed, distance, or the length of a trip, or how long a trip (or a job) takes. To solve rate problems, use the Rate Pie.

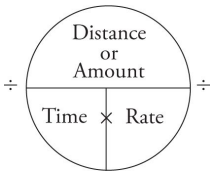

A rate problem is really just an average problem.

The Rate Pie works exactly the same way as the Average Pie. If you divide the *distance* or *amount* by the *rate*, you get the *time*. If you divide the *distance* or *amount* by the *time*,

you get the *rate*. If you multiply the *rate* by the *time*, you get the *distance* or *amount*.

Let's take a look.

It takes Carla three hours to drive to her brother's house at an average speed of 50 miles per hour. If she takes the same route home, but her average speed is 60 miles per hour, what is the time, in hours, that it takes her to drive home?

- 2 hours
- 2 hours and 14 minutes
- 2 hours and 30 minutes
- 2 hours and 45 minutes
- 3 hours

Here's How to Crack It

The trip to her brother's house takes three hours, and the rate is 50 miles per hour. Plug those numbers into a Rate Pie and multiply to find the distance.

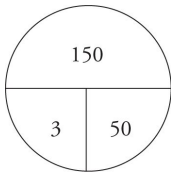

So the distance is 150 miles. On her trip home, Carla travels at a rate of 60 miles per hour. Draw another Rate Pie and Plug In 150 and 60. Then all you have to do is divide 150 by 60 to find the time.

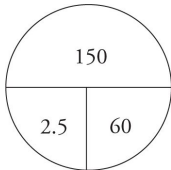

So it takes Carla two and a half hours to get home. That's answer choice (C).



Try another one.



A machine can stamp 20 envelopes in 4 minutes. How many of these machines, working simultaneously, are needed to stamp 60 envelopes per minute?

- 5
- 10
- 12
- 20
- 24

Here's How to Crack It

First we have to find the rate per minute of one machine. Plug 20 and 4 into a Rate Pie and divide to find the rate.

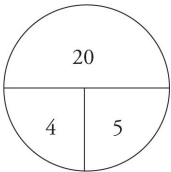

The rate is 5. If one machine can stamp 5 envelopes per minute, how many machines do you need to stamp 60 per minute? $60 \div 5 = 12$, or answer choice (C).



CHARTS

Every GRE Math section has a few questions that are based on a chart or graph (or on a group of charts or graphs). But don't worry; the most important thing that chart questions test is your ability to remember the difference between real-life charts and ETS charts.

Chart questions frequently test percents, percent change, ratios, proportions, and averages.

In real life, charts are often provided in order to display information in a way that's easier to understand. Conversely, ETS constructs charts to hide information you need to know and to make that information harder to understand.

Chart Questions

There are usually two or three questions per chart or per set of charts. Like the Reading Comprehension questions, chart questions appear on split screens. Be sure to click on the scroll bar and scroll down as far as you can; there may be additional charts underneath the top one, and you want to make sure you've seen all of them.

Chart problems just recycle the basic arithmetic concepts we've already covered: fractions, percentages, and so on. This means you can use the techniques we've discussed for each type of question, but there are two additional techniques that are especially important to use when doing chart questions.

On charts, look for the information ETS is trying to hide.



Don't Start with the Questions: Start with the Charts

Take a minute to note the following key bits of information from any chart you see.

- **Information in titles:** Make sure you know what each chart is telling you.
- **Asterisks, footnotes, parentheses, and small print:** Often there will be crucial information hidden away at the bottom of the chart. Don't miss it!

- 830/1507
- **Funny units:** Pay special attention when a title says “in thousands” or “in millions.” You can usually ignore the units as you do the calculations, but you have to use them to get the right answer.

Approximate, Estimate, and Ballpark

Like some of our other techniques, you have to train yourself to estimate when working with charts and graphs questions. You should estimate, not calculate exactly, in the following situations:

- Whenever you see the word *approximately* in a question

- Whenever the answer choices are far apart in value
- Whenever you start to answer a question and you justifiably say to yourself, “This is going to take a lot of calculation!”

Don't try to work with huge values. Ballpark instead!

Review those “friendly” percentages and their fractions from earlier in the chapter. Try estimating this question:

What is approximately 9.6 percent of 21.4?

Here's How to Crack It

Use 10 percent as a friendlier percentage and 20 as a friendlier number. One-tenth of 20 is 2 (it says “approximately”—who are you to argue?). That’s all you need to do to answer most chart questions.

Chart Problems

Make sure you’ve read everything on the chart carefully before you try the first question.

EXPENDITURE ON METALS BY COMPANY X

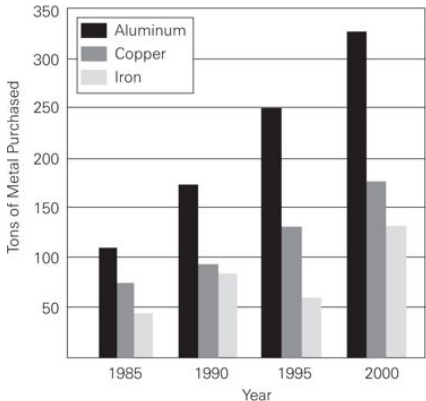

Year	Price of Aluminum Per Ton
1985	\$1,900
1990	\$2,200
1995	\$2,700
2000	\$3,400

Note: Graphs drawn to scale.

Approximately how many tons of aluminum and copper combined were purchased in 1995 ?

- 125
- 255
- 325

375

515

How much did Company X spend on aluminum in 1990 ?

\$675,000

\$385,000

\$333,000

\$165,000

\$139,000

Approximately what was the percent increase in the price of aluminum from 1985 to 1995 ?

8%

16%

- 23%
- 30%
- 42%

Here's How to Crack the First Question

As you can see from the graph on the previous page, in 1995, the black bar (which indicates aluminum) is at 250, and the dark grey bar (which indicates copper) is at approximately 125. Add those figures and you get the number of tons of aluminum and copper combined that were purchased in 1995: $250 + 125 = 375$. That's choice (D). Notice that the question says "approximately." Also notice that the numbers in the answer choices are pretty far apart.

Here's How to Crack the Second Question

We need to use the chart and the graph to answer this question, because we need to find the number of tons of aluminum purchased in 1990 and multiply it by the price per ton of aluminum in 1990 in order to figure out how much was spent on aluminum in 1990. The bar graph tells us that 175 tons of aluminum was purchased in 1990, and the little chart tells us that aluminum was \$2,200 per ton in 1990. $175 \times \$2,200 = \$385,000$. That's choice (B).

Here's How to Crack the Third Question

Remember that percent increase formula from earlier in this chapter?

$$\text{Percent change} = \frac{\text{Difference}}{\text{Original}} \times 100$$

We'll need to use the little chart for this one.

In 1985, the price of aluminum was \$1,900 per ton. In 1995, the price of aluminum was \$2,700 per ton. Now let's use the formula.

$2,700 - 1,900 = 800$, so that's the difference.

This is a percent increase problem, so the original number is the smaller one. Thus, the original is 1,900, and our formula looks like

this: $\text{Percent change} = \frac{800}{1,900} \times 100$. By

canceling the 0's in the fraction you get $\frac{8}{19} \times$
100, and multiplying gives you $\frac{800}{19}$. At this
point you could divide 800 by 19 to get the
exact answer, but because they're looking for
an approximation, let's round 19 to 20.
What's $800 \div 20$? That's 40, and answer
choice (E) is the only one that's close.



Real World Math Drill

Now it's time to try out what you have learned on some practice questions. Try the following problems and then check your answers in [Part V](#).

1 of 18

If $3(r + s) = 7$, then, in terms of r , s
=

- $\frac{7}{3} - r$
- $\frac{7}{3} + r$
- $7 - 3r$

$\frac{7}{3} - \frac{r}{3}$

$\frac{7}{3} + \frac{r}{3}$

2 of 18

Sadie sells half the paintings in her collection, gives one-third of her paintings to friends, and keeps the remaining paintings for herself. What fraction of her collection does Sadie keep?

Click on each box and type in a number.

Backspace to erase.

3 of 18

During a sale, a store decreases prices on all its scarves by 25 to 50 percent. If all of the scarves in the store originally cost \$20, which of the following could be the sale price of a scarf?

Indicate all such prices.

\$8

\$10

\$12

\$14

\$16

4 of 18

$$\theta x = x^{-3}(2x)\left(\frac{x}{2}\right)(2)$$

Quantity A

08

Quantity B

04

- Quantity A is greater.
- Quantity B is greater.
- The two quantities are equal.
- The relationship cannot be determined from the information given.

[5](#) of 18

$$5x - 2y = 2y - 3x$$

Quantity A x **Quantity B** y

- Quantity A is greater.
- Quantity B is greater.

- The two quantities are equal.
- The relationship cannot be determined from the information given.

Questions 6 through 9 refer to the following graph.

PERCENT OF POPULATION IN NEW ENGLAND
BY STATE IN YEAR X AND YEAR Y

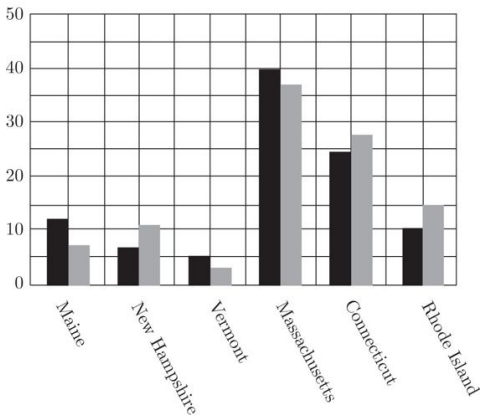

Note: Drawn to scale

- Year X: Total New England population= 15 million
- Year Y: Total New England population= 25 million

6 of 18

If the six New England states are ranked by population in Year X and Year Y , how many states would have a different ranking from Year X to Year Y ?

- None
- One
- Two
- Three
- Four

7 of 18

In Year X , the population of Massachusetts was approximately what percent of the population of Vermont?

- 50%
- 120%
- 300%
- 800%
- 1,200%

[8](#) of 18

By approximately how much did the population of Rhode Island increase from Year X to Year Y ?

- 750,000
- 1,250,000
- 1,500,000
- 2,250,000
- 3,375,000

[9](#) of 18

A water jug with a capacity of 20 gallons is 20 percent full. If an amount of water equal to 50 percent of the amount of water currently in the jug is added to the jug every 3 days, how many days does it take for the jug to be at least 85% full?

- 4
- 6
- 12
- 15
- 20

[10](#) of 18

Towns *A*, *B*, *C*, and *D* are all in the same voting district. Towns *A* and *B* have 3,000 people each who support

referendum R and the referendum has an average (arithmetic mean) of 3,500 supporters in towns B and D and an average of 5,000 supporters in Towns A and C .

Quantity A

The average number of supporters of Referendum R in Towns C and D

Quantity B

The average number of supporters of Referendum R in Towns B and C

- Quantity A is greater.
- Quantity B is greater.
- The two quantities are equal.
- The relationship cannot be determined from the information given.

[11](#) of 18

A company paid \$500,000 in merit raises to employees whose performances were rated A , B , or C . Each employee rated A received twice the amount of the raise that was paid to each employee rated C ; and each employee rated B received one-and-a-half times the amount of the raise that was paid to each employee rated C . If 50 workers were rated A , 100 were rated B , and 150 were rated C , how much was the raise paid to each employee rated A ?

- \$370
- \$625
- \$740
- \$1,250
- \$2,500

[12](#) of 18

The original price of an item at a store is 40 percent more than the price the retailer paid for it. To encourage sales, the retailer reduces the price of the item by 15 percent from the original selling price. If the retailer sells the item at the reduced cost, his profit is what percent of his cost?

percent

Click on the answer box and type in a number.

Backspace to erase.

Questions 13 through 15 refer to the following graphs.

NUMBER OF STUDENTS IN GRADES 9 THROUGH 12 FOR SCHOOL DISTRICT X IN 1995 AND 2013

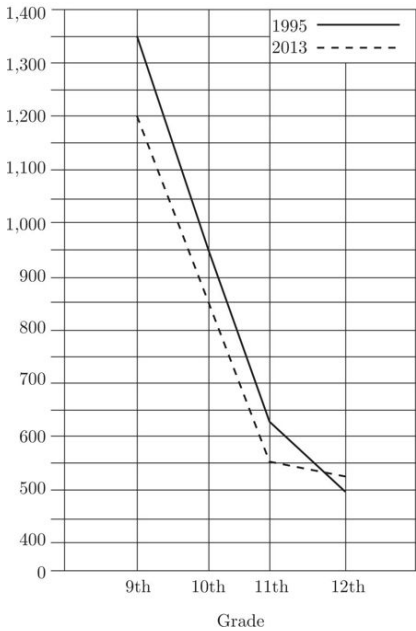

DISTRIBUTION OF READING TEST
SCORES* FOR SCHOOL DISTRICT X
STUDENTS IN 2013

(*Reading Test scores can range from
0–100 points)

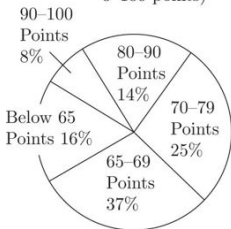

9th Grade Students

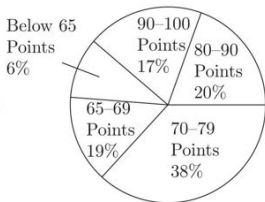

10th–12th Grade Students

Note: Drawn to scale.

[13](#) of 18

In 2013, the median reading test score for ninth grade students was in which score range?

- Below 65 points
- 65–69 points

- 70–79 points
- 80–89 points
- 90–100 points

[14](#) of 18

If the number of students in grades 9 through 12 comprised 35 percent of the number of students in School District X in 1995, then approximately how many students were in School District X in 1995 ?

- 9,700
- 8,700
- 3,400
- 3,000
- 1,200

15 of 18

Assume that all students in School District X took the reading test each year. In 2013, approximately how many more ninth grade students had reading test scores in the 70–79 point range than in the 80–89 point range?

- 470
- 300
- 240
- 170
- 130

16 of 18

$$x + 2y = 21$$
$$\frac{1}{2} \left(12x - \frac{24}{12}y \right) > 0$$

Quantity A x **Quantity B**

21

- Quantity A is greater.
- Quantity B is greater.
- The two quantities are equal.
- The relationship cannot be determined from the information given.

[17](#) of 18

One ounce of Solution X contains only ingredients a and b in a ratio of $2 : 3$. One ounce of Solution Y contains only ingredients a and b in a ratio of $1 : 2$. If Solution Z is created by mixing solutions X and Y in a ratio of $3 : 11$, then 630 ounces of

Solution Z contains how many ounces of a ?

- 68
- 73
- 89
- 219
- 236

[18](#) of 18

On Sunday, Belmont Public Library has 160 books, none of which have been checked out. On Monday, 40 of the books are checked out. On Tuesday, $\frac{1}{2}$ of the borrowed books are

returned. Wednesday, $\frac{1}{2}$ of the books still checked out are returned and then 20 more are checked out. On Thursday, a wealthy patron donates 80 books, and $\frac{1}{6}$ of the books still checked out are returned. On Friday 30 more books are borrowed, and on Saturday 35 are checked out. What is the percent change from the books in the library at the end of the day on Monday to the books in the library at end of the day the following Saturday?

percent

Click on the answer box and type in a
number.

Backspace to erase.

Summary

- Fractions, decimals, and percents are all ways of expressing parts of integers.
- Translation is a useful tool for converting fraction and percent problems into mathematical equations.
- Percent change is expressed as the difference between two numbers divided by the original number $\times 100$.
- Plug In on questions that ask about percents or fractions of an unknown amount.
- A ratio expresses a part to part relationship. The key to ratio problems is

finding the total. Use the ratio box to organize ratio questions.

- A proportion expresses the relationship between equal fractions, percents, or ratios. A proportion problem always provides you with three pieces of information and asks you for a fourth.
- Use the Average Pie to organize and crack average problems.
- The median is the middle number in a set of values. The mode is the value that appears most frequently in a set. The range of a set is the difference between the largest and smallest values in the set.
- You will never have to calculate standard deviation on the GRE.

- Standard deviation problems are really average and percent problems. Make sure you know the percentages associated with the bell curve: 34%–14%–2%.
- Use the Rate Pie for rate questions.
- On chart questions, make sure you take a moment to understand what information the chart is providing. Estimate answers to chart questions whenever possible.

Chapter 12

Geometry

Chances are you probably haven't used the Pythagorean theorem recently or had to find the area of a circle in quite a while. However, you'll be expected to know geometry concepts such as these on the GRE. This chapter reviews all the important rules and formulas you'll need to crack the geometry problems on the GRE. It also provides examples of how such concepts will be tested on the GRE Math section.

WHY GEOMETRY?

Good question. If you're going to graduate school for political science or linguistics or history or practically anything that doesn't involve math, you might be wondering why the heck you have to know the area of a circle or the Pythagorean theorem for this exam. While we may not be able to give you a satisfactory answer to that question, we can help you do well on the geometry questions on the GRE.

Expect to see a handful of basic geometry problems on each of your Math sections.

WHAT YOU NEED TO KNOW

The good news is that you don't need to know much about actual geometry to do well on the GRE; we've boiled down geometry to the handful of bits and pieces that ETS actually tests.

Before we begin, consider yourself warned: Since you'll be taking your test on a computer screen, you'll have to be sure to transcribe all the figures onto your scrap paper accurately. All it takes is one mistaken angle or line and you're sure to get the problem wrong. So make ample use of your scratch paper and always double-check your figures. Start practicing now, by using scratch paper with this book.

Another important thing to know is that you cannot necessarily trust the diagrams ETS

gives you. Sometimes they are very deceptive and are intended to confuse you. Always go by what you read, not what you see.

Problem-solving questions will be drawn to scale unless they clearly tell you otherwise. Quant comp questions, on the other hand, may *not* be drawn to scale, so be on your guard!



DEGREES, LINES, AND ANGLES

For the GRE, you will need to know that

1. A line is a 180-degree angle. In other words, a line is a perfectly flat angle.
2. When two lines intersect, four angles are formed; the sum of these angles is 360 degrees.
3. When two lines are perpendicular to each other, their intersection forms four 90-degree angles. Here is the symbol ETS uses to indicate perpendicular lines: \perp .
4. Ninety-degree angles are also called *right angles*. A right angle on the GRE is identified by a little box at the intersection of the angle's arms:

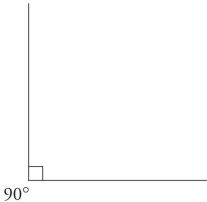

5. The three angles inside a triangle add up to 180 degrees.
6. The four angles inside any four-sided figure add up to 360 degrees.
7. A circle contains 360 degrees.
8. Any line that extends from the center of a circle to the edge of the circle is called a *radius* (plural is *radii*).

Vertical Angles

Vertical angles are the angles that are across from each other when two lines intersect. Vertical angles are always equal. In the drawing below, angle x is equal to angle y

(they are vertical angles) and angle a is equal to angle b (they are also vertical angles).

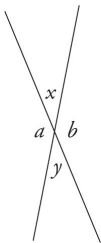

On the GRE, the measure of only one of the vertical angles is typically shown.

But usually you'll need to use the other angle to solve the problem.

Parallel Lines

Parallel lines are lines that never intersect. When a pair of parallel lines is intersected by a third, two types of angles are formed: big angles and small angles. Any big angle is

equal to any big angle, and any small angle is equal to any small angle. The sum of any big angle and any small angle will always equal 180. When ETS tells you that two lines are parallel, this is what is being tested. The symbol for parallel lines and the word *parallel* are both clues that tell you what to look for in the problem. The minute you see either of them, immediately identify your big and small angles; they will probably come into play.

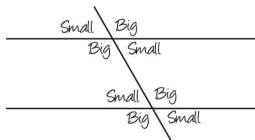

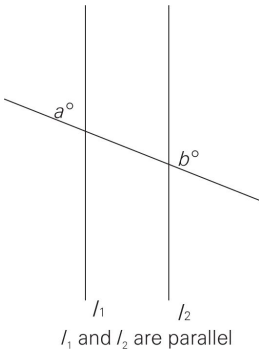

Quantity A

$$a + b$$

Quantity B

$$180$$

- Quantity A is greater.
- Quantity B is greater.
- The two quantities are equal.
- The relationship cannot be determined from the information given.

Here's How to Crack It

Notice that you're told that these lines are parallel. Here's one very important point: You need to be told that. You can't assume that they are parallel just because they look like they are.

Okay, so as you just learned, only two angles are formed when two parallel lines are intersected by a third line: a big angle (greater than 90 degrees) and a small one (smaller than 90 degrees). Look at angle a . It looks smaller than 90, right? Now look at angle b . It looks bigger than 90, right? You also know that $a + b$ must add up to 180. The answer is (C).



TRIANGLES

Triangles are perhaps ETS's favorite geometrical shape. Triangles have many properties, which make them great candidates for standardized test questions. Make sure you familiarize yourself with the following triangle facts.

Triangles are frequently tested on the GRE.

The Rule of 180°

Every triangle contains three angles that add up to 180 degrees. You must know this fact cold for the exam. This rule applies to every triangle, no matter what it looks like. Here are some examples:

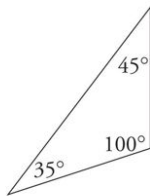
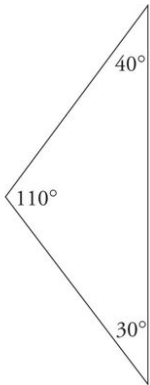
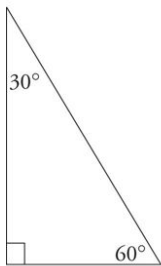

Equilateral Triangles

An **equilateral triangle** is a triangle in which all three sides are equal in length. Because all of the sides are equal in these triangles, all of the angles are equal. Each angle is 60 degrees because 180 divided by 3 is 60.

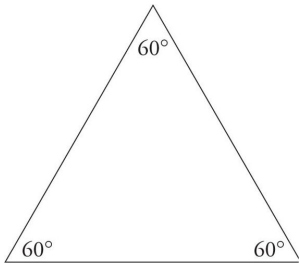

Isosceles Triangles

An **isosceles triangle** is a triangle in which two of the three sides are equal in length. This means that two of the angles are also equal.

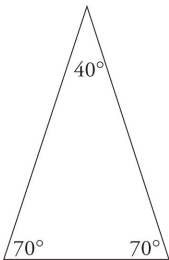

Angle/Side Relationships in Triangles

In any triangle, the longest side is opposite the largest interior angle; the shortest side is opposite the smallest interior angle. That's why the hypotenuse of a right triangle is its longest side—there couldn't be another angle in the triangle bigger than 90 degrees. Furthermore, equal sides are opposite equal angles.

Perimeter of a Triangle

The perimeter of a triangle is simply a measure of the distance around it. All you have to do to find the perimeter of a triangle is add up the lengths of the sides.

The Third Side Rule

Why is it impossible for the following triangle to exist? (Hint: It's not drawn to scale.)

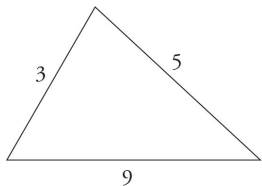

This triangle could not exist because the length of any one side of a triangle is limited by the lengths of the other two sides. This can be summarized by the **third side rule**:

The length of any one side of a triangle must be less than the sum of the other two sides and greater than the difference between the other two sides.

This rule is not tested frequently on the GRE, but when it is, it's usually the key to solving the problem. Here's what the rule means in application: Take the lengths of any two sides of a triangle. Add them together, then subtract one from the other. The length of the third side must lie between those two numbers.

Take the sides 3 and 5 from the triangle above. What's the longest the third side could measure? Just add and subtract. It could not be as long as 8 ($5 + 3$) and it could not be as short as 2 ($5 - 3$).

Therefore, the third side must lie between 2 and 8. It's important to remember that the third side cannot be equal to either 2 or 8. It must be greater than 2 and less than 8.

Try the following question:

A triangle has sides 4, 7, and x .
Which of the following could be the
perimeter of the triangle?

Indicate all such perimeters.

13

16

17

20

22

Here's How to Crack It

The perimeter of a triangle is equal to the sum of its three sides. So far, we have sides of 4 and 7, so our partial perimeter is $4 + 7 = 11$. What about the third side, x ? The third-side rule tells us that the side could not be longer than $7 + 4 = 11$ or shorter than $7 - 4 = 3$. The third side must be greater than 3 and

less than 11. Next we add the partial perimeter, 11, to both of these numbers to find the range of the perimeter. $11 + 3 = 14$ and $11 + 11 = 22$, so the perimeter must be greater than 14 and less than 22. Only choices (A) and (E) fall outside this range. For this question, we have to click on all of the answers that work, so the best answer is (B), (C), and (D).

Any time you see the word *area* or any other word that indicates that a formula is to be used, write the formula on your scratch paper and park the information you're given directly underneath.

Area of a Triangle

The area of any triangle is equal to its height (or altitude) multiplied by its base, divided by 2, so

$$A = \frac{1}{2}bh$$

The height of a triangle is defined as the length of a perpendicular line drawn from the point of the triangle to its base.



The height of a triangle must be perpendicular to the base.

This area formula works on any triangle.

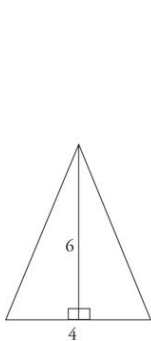

$$\text{area} = 12$$



$$\text{area} = 12$$

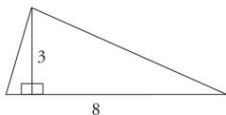

$$\text{area} = 12$$

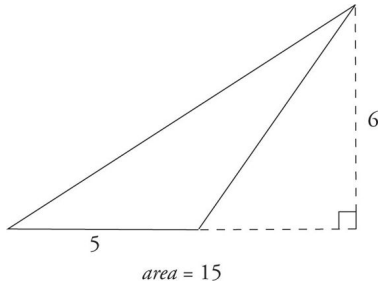

The Pythagorean Theorem

The Pythagorean theorem applies only to right triangles. This theorem states that in a right triangle, the square of the length of the hypotenuse (the longest side, remember?) is equal to the sum of the squares of the lengths of the two other sides. In other words, $c^2 = a^2 + b^2$, where c is the length of the hypotenuse and a and b are the lengths of the other sides. (The two sides that are not the hypotenuse are called the legs.)

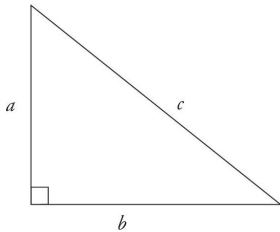

ETS will sometimes try to intimidate you by using multiples of the common Pythagorean triples. For example, you might see a 10-24-26 triangle. That's just a 5-12-13 in disguise though.

You can always use the Pythagorean theorem to calculate the third side of a right triangle.

Here are the most common right triangles:

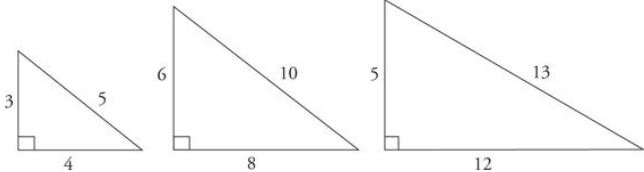

Note that a triangle could have sides with actual lengths of 3, 4, and 5, or $3 : 4 : 5$ could just be the ratio of the sides. If you double the ratio, you get a triangle with sides equal to 6, 8, and 10. If you triple it, you get a triangle with sides equal to 9, 12, and 15.

Let's try an example.

Write everything down on scratch paper! Don't do anything in your head.



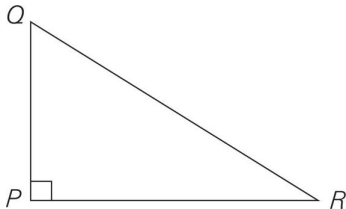

In the figure above, if the distance from point P to point Q is 6 miles and the distance from point Q to point R is 10 miles, what is the distance from point P to point R ?

- 4
- 5
- 6
- 7
- 8

Here's How to Crack It

Once you've sensitized yourself to the standard right triangles, this problem couldn't be easier. When you see a right triangle, be suspicious. One leg is 6. The hypotenuse is 10. The triangle has a ratio of 3 : 4 : 5. Therefore, the third side (the other leg) must be 8.



The Pythagorean theorem will sometimes help you solve problems that involve squares or rectangles. For example, every rectangle or square can be divided into two right triangles. This means that if you know the length and width of any rectangle or square, you also know the length of the diagonal—it's the shared hypotenuse of the hidden right triangles.

Here's an example:

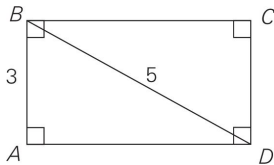

In the rectangle above, what is the area of triangle ABD ?

Click on the answer box and type in a number.

Backspace to erase.

Here's How to Crack It

We were told that this is a rectangle (remember that you can never assume!), which

means that triangle ABD is a right triangle. Not only that, but it's a 3 : 4 : 5 right triangle (with a side of 3 and a hypotenuse of 5, it must be), with side $AD = 4$. So, the area of triangle ABD is $\frac{1}{2}$ the base (3) times the height (4). That's $\frac{1}{2}$ of 12, otherwise known as 6. You could enter that value into the box.



Right Isosceles Triangles

If you take a square and cut it in half along its diagonal, you will create a right isosceles triangle. The two sides of the square stay the same. The 90-degree angle will stay the same, and the other two angles that were 90

degrees each get cut in half and are now 45 degrees. The ratio of sides in a right isosceles triangle is $x : x : x\sqrt{2}$. This is significant for two reasons. First, if you see a problem with a right triangle and there is a $\sqrt{2}$ anywhere in the problem, you know what to look for. Second, you always know the length of the diagonal of a square because it is one side times the square root of two.

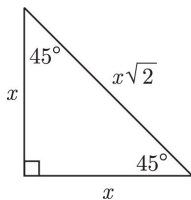

You always know the length of the diagonal

of a square because it is
one side of the square
times $\sqrt{2}$.

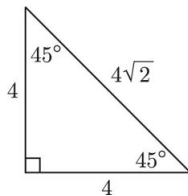
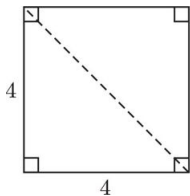

Let's try an example involving a special right triangle.

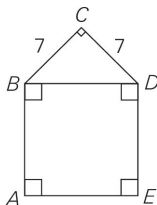

In the figure above, what is the area of square $ABDE$?

- $28\sqrt{2}$
- 49
- $49\sqrt{2}$
- 98
- $98\sqrt{2}$

Here's How to Crack It

In order to figure out the area of square $ABDE$, we need to know the length of one of its sides. We can get the length of BD by using the isosceles right triangle attached to it. BD is the hypotenuse, which means its length is $7\sqrt{2}$. To get the area of the square we have to square the length of the side we

know, or $(7\sqrt{2})(7\sqrt{2}) = (49)(2) = 98$. That's choice (D).



30 : 60 : 90 Triangles

If you take an equilateral triangle and draw in the height, you end up cutting it in half and creating a right triangle. The hypotenuse of the right triangle has not changed; it's just one side of the equilateral triangle. One of the 60 degree angles stays the same as well. The angle where the height meets the base is 90 degrees, naturally, and the side that was the base of the equilateral triangle has been cut in half. The smallest angle, at the top, opposite the smallest side, is 30 degrees. The ratio of sides on a 30 : 60 : 90 triangle is $x : x : \sqrt{3} : 2x$. Here's what it looks like:

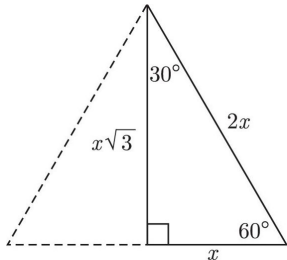

You can always calculate the area of an equilateral triangle because you know that the height is one half of one side times $\sqrt{3}$.

This is significant for two reasons. The first is that if you see a problem with a right triangle and one side is double the other or there is a $\sqrt{3}$ anywhere in the problem, you know what to look for. The second is that you always know the area of an equilateral triangle because you always know the height. The height is one half of one side times the square root of three.

Here's one more:

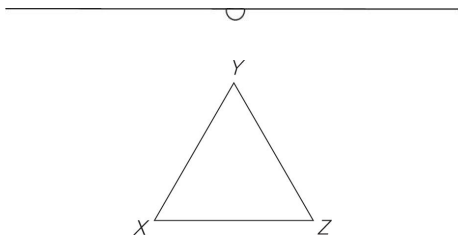

Triangle XYZ in the figure above is an equilateral triangle. If the perimeter of the triangle is 12, what is its area?

- $2\sqrt{3}$
- $4\sqrt{3}$
- 8
- 12
- $8\sqrt{3}$

908/1507
If you see $\sqrt{2}$ or $\sqrt{3}$ in the answer choices of the problem it's a tip-off that the problem is testing special right triangles.

Here's How to Crack It

Here we have an equilateral triangle with a perimeter of 12, which means that each side has a length of 4 and each angle is 60 degrees. Remember that in order to find the area of a triangle, we use the triangle area formula: $A = \frac{1}{2}bh$, but first we need to know the base and the height of the triangle. The base is 4, which now gives us $A = \frac{1}{2}4h$, and

now the only thing we need is the height. Remember: The height always has to be perpendicular to the base. Draw a vertical line that splits the equilateral triangle in half. The top angle is also split in half, so now we have this:

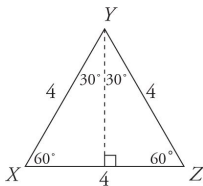

What we've done is create two $30 : 60 : 90$ right triangles, and we're going to use one of these right triangles to find the height. Let's use the one on the right. We know that the hypotenuse in a $30 : 60 : 90$ right triangle is always twice the length of the short side.

Here we have a hypotenuse (YZ) of 4, so our short side has to be 2. The long side of a $30 : 60 : 90$ right triangle is always equal to the short side multiplied by the square root of 3. So if our short side is 2, then our long side must be $2\sqrt{3}$. That's the height.

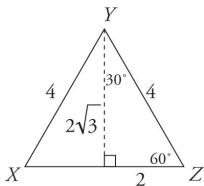

Finally, we return to our area formula. Now

we have $A = \frac{1}{2} \times 4 \times 2\sqrt{3}$. Multiply it out and you get $A = 4\sqrt{3}$. The answer is (B).



FOUR-SIDED FIGURES

The four angles inside any figure that has four sides add up to 360 degrees. That includes rectangles, squares, and parallelograms. Parallelograms are four-sided figures made out of two sets of parallel lines whose area can be found with the formula $A = bh$, where h is the height of a line drawn perpendicular to the base.

Perimeter of a Rectangle

The perimeter of a rectangle is just the sum of the lengths of its four sides.

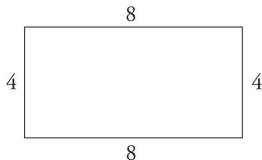

$$\textit{perimeter} = 4 + 8 + 4 + 8$$

The area of a rectangle is equal to its length times its width. For example, the area of the rectangle above is 32 (or 8×4).

Area of a Rectangle

The area of a rectangle is equal to its length times its width. For example, the area of the rectangle above is 32 (or 8×4).

Squares

A square has four equal sides. The perimeter of a square is, therefore, 4 times the length of any side. The area of a square is equal to the length of any side times itself, or in other words, the length of any side, squared. The diagonal of a square splits it into two 45 : 45 : 90, or isosceles, right triangles.

CIRCLES

Circles are a popular test topic for ETS. There are a few properties that the GRE likes to test over and over again and problems with circles also always seem to use that funny little symbol π . Here's all you need to know about circles.

The World of Pi

You may remember being taught that the value of pi (π) is 3.14, or even 3.14159. On the GRE, $\pi = 3$ ish is a close enough approximation. You don't need to be any more precise than that when doing GRE problems.

What you might not recall about pi is that pi (π) is the ratio between the

circumference of a circle and its diameter. When we say that π is a little bigger than 3, we're saying that every circle is about three times as far around as it is across.

Chord, Radius, and Diameter

A **chord** is a line that connects two points on the circumference of a circle. The **radius** of a circle is any line that extends from the center of the circle to a point on the circumference of the circle. The **diameter** of a circle is a line that connects two points on the circumference of the circle and that goes through the center of the circle. Therefore, the diameter of a circle is twice as long as its radius. Notice as well that the diameter of a

circle is also the longest chord and that a radius is not a chord.

The radius is always the key to circle problems.

Circumference of a Circle

The **circumference** of a circle is like the perimeter of a triangle: It's the distance around the outside. The formula for finding the circumference of a circle is 2 times π times the radius, or π times the diameter.

Circumference is just a fancy way of saying perimeter.

$$\text{circumference} = 2\pi r \text{ or } \pi d$$

If the diameter of a circle is 4, then its circumference is 4π , or roughly 12+. If the diameter of a circle is 10, then its circumference is 10π , or a little more than 30.

An **arc** is a section of the outside, or circumference, of a circle. An angle formed by two radii is called a **central angle** (it comes out to the edge from the center of the circle). There are 360 degrees in a circle, so if there is an arc formed by, say, a 60-degree central angle, and 60 is $\frac{1}{6}$ of 360, then the arc formed by this 60-degree central angle will be $\frac{1}{6}$ of the circumference of the circle.

Area of a Circle

The area of a circle is equal to π times the square of its radius.

When working with π , leave it as π in your calculations.

Also, leave $\sqrt{3}$ as $\sqrt{3}$. The answer will have them that way.

$$\text{area} = \pi r^2$$

Let's try an example of a circle question.

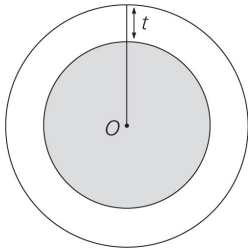

Note: Figure not drawn to scale.

In the wheel above, with center O , the area of the entire wheel is 169π . If the area of the shaded hubcap is 144π , then $t =$

Click on the answer box and type in a number.

Backspace to erase.

Here's How to Crack It

We have to figure out what t is, and it's going to be the length of the radius of the entire wheel minus the length of the radius of the hubcap. If the area of the entire wheel is 169π , the radius is $\sqrt{169}$, or 13. If the area of the hubcap is 144π , the radius is $\sqrt{144}$, or 12. $13 - 12 = 1$. Enter this value into the box.



Let's try another one.

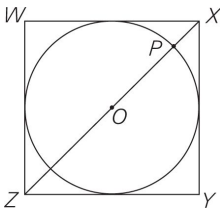

In the figure above, a circle with the center O is inscribed in square $WXYZ$. If the circle has radius 3, then $PZ =$

- 6
- $3\sqrt{2}$
- $6 + \sqrt{2}$
- $3 + \sqrt{3}$
- $3\sqrt{2} + 3$

Ballparking answers will help you eliminate choices.

Here's How to Crack It

Inscribed means that the edges of the shapes are touching. The radius of the circle is 3, which means that PO is 3. If Z were at the other end of the diameter from P , this

problem would be easy and the answer would be 6, right? But Z is beyond the edge of the circle, which means that PZ is a little more than 6. Let's stop there for a minute and glance at the answer choices. We can eliminate anything that's "out of the ballpark"—in other words, any answer choice that's less than 6, equal to 6 itself, or a lot more than 6. Remember when we told you to memorize a few of those square roots?

Let's use them:

- (A) Exactly 6? Nope.
- (B) That's 1.4×3 , which is 4.2. Too small.
- (C) That's $6 + 1.4$, or 7.4. Not bad. Let's leave that one in.
- (D) That's $3 + 1.7$, or 4.7. Too small.

(E) That's $(3 \times 1.4) + 3$, which is $4.2 + 3$, or 7.2 . Not bad. Let's leave that one in, too.

So we eliminated three choices with Ballparking. We're left with (C) and (E). You could take a guess here if you had to, but let's do a little more geometry to find the correct answer.

Because this circle is inscribed in the square, the diameter of the circle is the same as a side of the square. We already know that the diameter of the circle is 6, so that means that ZY , and indeed all the sides of the square, are also 6. Now, if ZY is 6, and XY is 6, what's XZ , the diagonal of the square? Well, XZ is also the hypotenuse of the isosceles right triangle XYZ . The hypotenuse of a right triangle with two sides of 6 is $6\sqrt{2}$. That's approximately 6×1.4 , or 8.4 .

The question is asking for PZ , which is a little less than XZ . It's somewhere between 6 and 8.4. The pieces that aren't part of the diameter of the circle are equal to $8.4 - 6$, or 2.4. Divide that in half to get 1.2, which is the distance from the edge of the circle to Z . That means that PZ is $6 + 1.2$, or 7.2. Check your remaining answers: Choice (C) is 7.4, and choice (E) is 7.2. Bingo! The answer is (E).



THE COORDINATE SYSTEM

On a coordinate system, the horizontal line is called the ***x*-axis** and the vertical line is called the ***y*-axis**. The four areas formed by the intersection of these axes are called **quadrants**. The point where the axes intersect is called the **origin**. This is what it looks like:

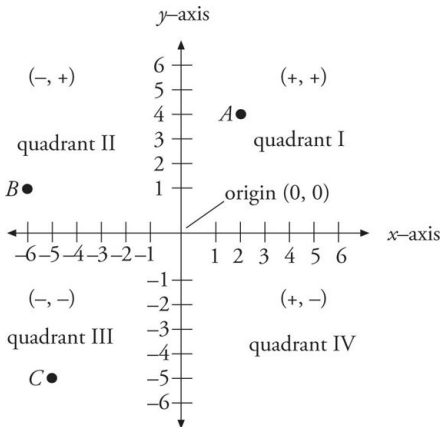

Coordinate geometry questions often test basic shapes such as triangles and squares.

To express any point in the coordinate system, you first give the horizontal value, then the vertical value, or (x, y) . In the diagram above, point A can be described by the coordinates $(2, 4)$. That is, the point is two spaces to the right of the origin and four spaces above the origin. Point B can be described by the coordinates $(-6, 1)$. That is, it is six spaces to the left and one space above the origin. What are the coordinates of point C ? Right, it's $(-5, -5)$.

Here's a GRE example:

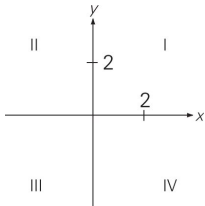

Points $(x, 5)$ and $(-6, y)$, not shown in the figure above, are in quadrants I and III, respectively. If $xy \neq 0$, in which quadrant is point (x, y) ?

- IV
- III
- II
- I
- It cannot be determined from the information given.

Here's How to Crack It

If point $(x, 5)$ is in quadrant I, that means x is positive. If point y is in quadrant III, then y is negative. The quadrant that would contain coordinate points with a positive x and a negative y is quadrant IV. That's answer choice (A).

Slope

Trickier questions involving the coordinate system might give you the equation for a line on the grid, which will involve something called the slope of the line. The equation of a line is

$$y = mx + b$$

In this equation x and y are both points on the line, b stands for the y -intercept, or the point at which the line crosses the y -axis, and m is the slope of the line. **Slope** is defined as the vertical change divided by the horizontal change, often called “the rise over the run” or the “change in y over the change in x .”

$$\text{Slope} = \frac{\text{rise}}{\text{run}} = \frac{(y_2 - y_1)}{(x_2 - x_1)}$$

Sometimes on the GRE, m is written instead as a , as in $y = ax + b$. You’ll see all this in action in a moment.

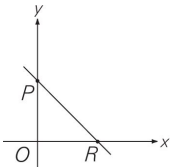

The line $y = -\frac{8}{7}x + 1$ is graphed on the rectangular coordinate axes.

Quantity A

OR

Quantity B

OP

- Quantity A is greater.
- Quantity B is greater.
- The two quantities are equal.
- The relationship cannot be determined from the information given.

Here's How to Crack It

The y -intercept, or b , in this case is 1. That means the line crosses the y -axis at 1. So the coordinates of point P are $(0, 1)$. Now we have to figure out what the coordinates of point R are. We know the y -coordinate is 0, so let's stick that into the equation (the slope and the y -intercept are constant; they don't change).

$$y = mx + b$$

$$0 = -\frac{8}{7}x + 1$$

Now let's solve for x .

$$0 = -\frac{8}{7}x + 1$$

$$0 - 1 = -\frac{8}{7}x + 1 - 1$$

$$-1 = -\frac{8}{7}x$$

$$\left(-\frac{7}{8}\right)(-1) = \left(-\frac{7}{8}\right)\left(-\frac{8}{7}\right)x$$

$$\frac{7}{8} = x$$

So the coordinates of point R are $\left(\frac{7}{8}, 0\right)$. That means OR , in Quantity A, is equal to $\frac{7}{8}$, and OP , in Quantity B, is equal to 1. The answer is (B).

Another approach to this question would be to focus on the meaning of slope. Because

the slope is $-\frac{8}{7}$, that means the vertical change is 8 and the horizontal change is 7. In other words, you count up 8 and over 7. Clearly the rise is more than the run; thus OP is more than OR .



Incidentally, if you're curious about the difference between a positive and negative slope, any line that rises from left to right has a positive slope. Any line that falls from left to right has a negative slope. (A horizontal line has a slope of 0, and a vertical line is said to have "no slope.")

VOLUME

You can find the volume of a three-dimensional figure by multiplying the area of a two-dimensional figure by its height (or depth). For example, to find the volume of a rectangular solid, you would take the area of a rectangle and multiply it by the depth. The formula is lwh (length \times width \times height). To find the volume of a circular cylinder, take the area of a circle and multiply by the height. The formula is πr^2 times the height (or $\pi r^2 h$).

DIAGONALS IN THREE DIMENSIONS

There's a special formula that you can use if you are ever asked to find the length of a diagonal (the longest distance between any two corners) inside a three-dimensional rectangular box. It is $a^2 + b^2 + c^2 = d^2$, where a , b , and c are the dimensions of the figure (kind of looks like the Pythagorean theorem, huh?).

Questions that ask about diagonals are really about the Pythagorean theorem.

Take a look:



What is the length of the longest distance between any two corners in a rectangular box with dimensions 3 inches by 4 inches by 5 inches?

- 5
- 12
- $5\sqrt{2}$
- $12\sqrt{2}$
- 50

Here's How to Crack It

Let's use our formula, $a^2 + b^2 + c^2 = d^2$. The dimensions of the box are 3, 4, and 5.

$$3^2 + 4^2 + 5^2 = d^2$$

$$9 + 16 + 25 = d^2$$

$$50 = d^2$$

$$\sqrt{50} = d$$

$$\sqrt{25 \times 2} = d$$

$$\sqrt{25} \times \sqrt{2} = d$$

$$5\sqrt{2} = d$$

That's choice (C).



SURFACE AREA

The surface area of a rectangular box is equal to the sum of the areas of all of its sides. In other words, if you had a box whose dimensions were $2 \times 3 \times 4$, there would be two sides that are 2 by 3 (this surface would have an area of 6), two sides that are 3 by 4 (area of 12), and two sides that are 2 by 4 (area of 8). So, the total surface area would be $6 + 6 + 12 + 12 + 8 + 8$, which is 52.

Don't confuse surface area with volume.

Key Formulas and Rules

Here is a review of the key rules and formulas to know for the GRE Math section.

Lines and angles

- All straight lines have 180 degrees.
- A right angle measures 90 degrees.
- Vertical angles are equal.
- Parallel lines cut by a third lines have two angles, big angles and small angles. All of the big angles are equal and all of the small angles are equal. The sum of a big angle and a small angle is 180 degrees.

Triangles

- All triangles have 180 degrees.

- The angles and sides of a triangle are in proportion—the largest angle is opposite the largest side and the smallest side is opposite the smallest angle.
- The Pythagorean theorem is $c^2 = a^2 + b^2$ where c is the length of the hypotenuse.
- The area formula for a triangle is

$$A = \frac{bh}{2}$$

Quadrilaterals

- All quadrilaterals have 360 degrees.
- The area formula for a squares and rectangles is bh .

Circles

- All circles have 360 degrees.
- The radius is the distance from the center of the circle to any point on the edge.
- The area of a circle is πr^2 .
- The circumference of a circle is $2\pi r$.

PLUGGING IN ON GEOMETRY PROBLEMS

Remember: Whenever you have a question that has answer choices, like a regular multiple choice or a multiple choice, multiple answer question that has variables in the answer choices, Plug In. On geometry problems, you can Plug In values for angles or lengths as long as the values you Plug In don't contradict either the wording of the problem or the laws of geometry (you can't have the interior angles of a triangle add up to anything but 180, for instance).

Here's an example:



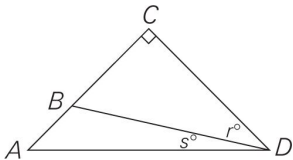

In the drawing above, if $AC = CD$,
then $r =$

- $45 - s$
- $90 - s$
- s
- $45 + s$
- $60 + s$

Here's How to Crack It

See the variables in the answer choices? Let's Plug In. First of all, we're told that AC and CD are equal, which means that ACD is an

isosceles right triangle. So angles A and D both have to be 45 degrees. Now it's Plugging In time. The smaller angles, r and s , must add up to 45 degrees, so let's make $r = 40$ degrees and $s = 5$ degrees. The question asks for the value of r , which is 40, so that's our target answer. Now eliminate answer choices by Plugging In 5 for s .

Don't forget to Plug In on geometry questions. Just pick numbers according to the rules of geometry.

- (A) $45 - 5 = 40$. Bingo! Check the other choices to be sure.
- (B) $90 - 5 = 85$. Nope.
- (C) 5. Nope.
- (D) $45 + 5 = 50$. Eliminate it.
- (E) $60 + 5 = 65$. No way.

By the way, we knew that the correct answer couldn't be greater than 45 degrees, because that's the measure of the entire angle D , so you could have eliminated (D) and (E) right away.



DRAW IT YOURSELF

When ETS doesn't include a drawing with a geometry problem, it usually means that the drawing, if supplied, would make ETS's answer obvious. In cases like this, you should just draw it yourself. Here's an example:



Quantity A

Quantity B

The diameter of a
circle with area
 49π

14

- Quantity A is greater.
- Quantity B is greater.
- The two quantities are equal.

- The relationship cannot be determined from the information given.

Here's How to Crack It

Visualize the figure. If the area is 49π , what's the radius? Right: 7. And if the radius is 7, what's the diameter? Right: 14. The answer is (C).



Redraw

On tricky quant comp questions, you may need to draw the figure once, eliminate two answer choices, and then draw it another way to try to disprove your first answer and to see if the answer is (D). Here's an example of a problem that might require you to do this:

For quant comp geometry questions, draw, eliminate, and REDRAW; it's like Plugging In twice.

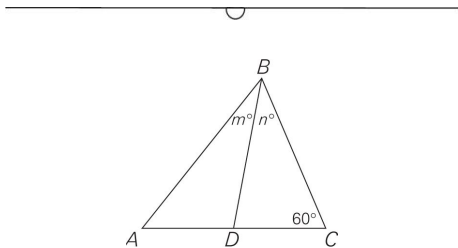

D is the midpoint of AC .

Quantity A

m

Quantity B

n

- Quantity A is greater.
- Quantity B is greater.

- The two quantities are equal.
- The relationship cannot be determined from the information given.

Here's How to Crack It

Are you sure that the triangle looks exactly like this? Nope. We know only what we are told—that the lengths of AD and DC are equal; from this figure, it looks like angles m and n are also equal. Because this means that it's possible for them to be, we can eliminate choices (A) and (B). But let's redraw the figure to try to disprove our first answer.

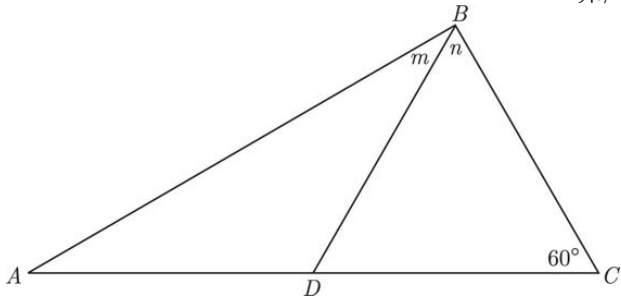

Try drawing the triangle as stretched out as possible. Notice that n is now clearly greater than m , so you can eliminate (C), and the answer is (D).



Geometry Drill

Think you have mastered these concepts? Try your hand at the following problems and check your work after you have finished. You can find the answers in [Part V](#).

1 of 15

Which of the following could be the degree measures of two angles in a right triangle?

Indicate all such angles.

20° and 70°

30° and 60°

45° and 45°

55° and 55°

75° and 75°

2 of 15

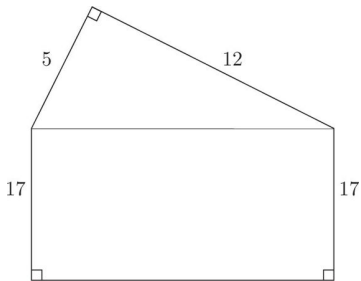

What is the perimeter of the figure above?

51

64

68

77

3 of 15

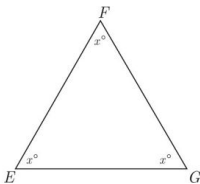
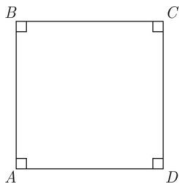

$$AB = BC = EG$$

$$FG = 8$$

Quantity A

The area of
square $ABCD$

Quantity B

32

- Quantity A is greater.
- Quantity B is greater.
- The two quantities are equal.

- The relationship cannot be determined from the information given.

4 of 15

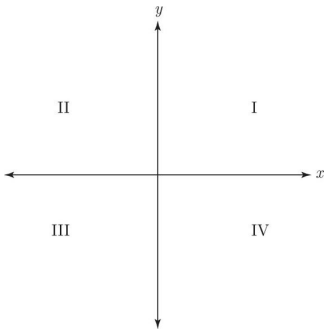

$(a, 6)$ is a point (not shown) in quadrant I.

$(-6, b)$ is a point (not shown) in quadrant II.

Quantity A

Quantity B

a b

- Quantity A is greater.
- Quantity B is greater.
- The two quantities are equal.
- The relationship cannot be determined from the information given.

5 of 15

A piece of twine with length of t is cut into two pieces. The length of the longer piece is 2 yards greater than 3 times the length of the shorter piece. Which of the following is the length, in yards, of the longer piece?

- $\frac{t + 3}{3}$

- $\frac{3t + 2}{3}$
- $\frac{t - 2}{4}$
- $\frac{3t + 4}{4}$
- $\frac{3t + 2}{4}$

6 of 15

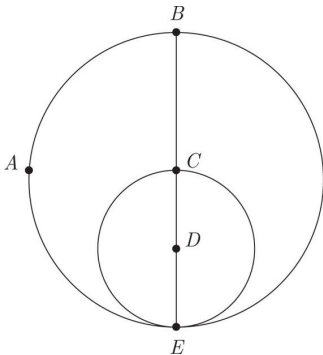

The circle with center D is drawn inside the circle with center C , as shown in the figure above. If $CD = 3$, what is the area of semicircle EAB ?

- $\frac{9}{2}\pi$
- 9π
- 12π
- 18π
- 36π

[7](#) of 15

For the final exam in a scuba diving certification course, Karl navigates from one point in a lake to another. Karl begins the test x meters directly beneath the boat and swims straight down toward the bottom of the lake

for 8 meters. He then turns to his right and swims in a straight line parallel to the surface of the lake and swims 24 meters, at which point he swims directly from his location, in a straight line, back to the boat. If the distance that Karl swims back to the boat is 26 meters, what is the value of x ?



Click on the answer box and type in a number.

Backspace to erase.

[8](#) of 15

Quantity A

Quantity B

The circumference of a circular region with radius r

The perimeter of a square with side r

- Quantity A is greater.
- Quantity B is greater.
- The two quantities are equal.
- The relationship cannot be determined from the information given.

9 of 15

Triangle ABC is contained within a circle with center C . Points A and B lie on the circle. If the area of circle C is 25π , and the measure of angle ACB is 60° , which of the following are possible lengths for side AB of triangle ABC ?

Indicate all such lengths.

3

4

5

6

7

10 of 15

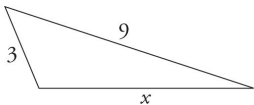

Quantity A

x

Quantity B

5.9

- Quantity A is greater.
- Quantity B is greater.

- The two quantities are equal.
- The relationship cannot be determined from the information given.

11 of 15

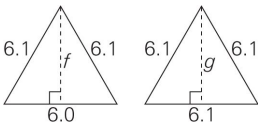

Quantity A

f

Quantity B

g

- Quantity A is greater.
- Quantity B is greater.
- The two quantities are equal.

- The relationship cannot be determined from the information given.

12 of 15

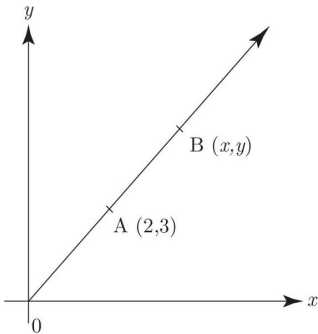

Given points $A(2, 3)$ and $B(x, y)$ in the rectangular coordinate system above, if $y = 4.2$, then $x =$

- 2.6
- 2.8

- 2.9
- 3.0
- 3.2

13 of 15

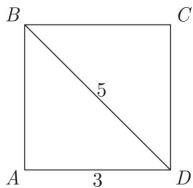

In rectangle $ABCD$ above, which of the following is the area of the triangle ABD ?

- 6
- 7.5
- 10
- 12

15

14 of 15

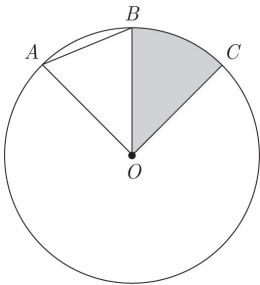

The circle above has a center O .

$$\angle AOB = \angle BOC$$

Quantity A

The area of triangle AOB

Quantity B

The area of the shaded region

- Quantity A is greater.
- Quantity B is greater.

- The two quantities are equal.
- The relationship cannot be determined from the information given.

[15](#) of 15

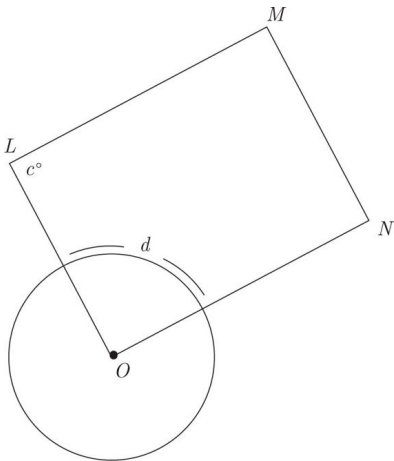

The circumference of the circle with center O shown above is 15π . $LMNO$

is a parallelogram and $\angle OLM = 108^\circ$.

What is the length of the minor arc?

- 15π
- 9π
- 3π
- 2π
- π

Summary

- There may only be a handful of geometry questions on the GRE, but you'll be expected to know a fair number of rules and formulas.
- Line and angle problems typically test your knowledge of vertical angles, parallel lines, right angles, and straight angles.
- Triangles are a popular geometry topic on the GRE. Make sure you know your triangle basics, including the total degrees of a triangle, the relationship between the angles and sides of a triangle, and the third side rule.

- Right triangle problems frequently test the Pythagorean theorem and the common Pythagorean triples $3 : 4 : 5$ and $5 : 12 : 13$.
- Be aware of the two special right triangles that ETS likes to torture test takers with: the $45 : 45 : 90$ triangle and $30 : 60 : 90$ triangle.
- Know the area formulas for triangles, rectangles, squares, and circles.
- Problems involving the coordinate plane frequently test common geometry concepts such as the area of a triangle or a square. Other plane geometry questions will test you on slope and the equation of a line.
- Slope is defined as rise over run. Find it by finding the change in y -

coordinates (the rise) and the change in x -coordinates (the run).

- The equation of a line is $y = mx + b$, where x and y are the coordinates of any point on the line, m is the slope and b is the y -intercept, the point at which the line crosses the y -axis.
- Don't forget to Plug In on geometry problems!

Chapter 13

Math Et Cetera

There are a few more math topics that may appear on the GRE that don't fit nicely into the preceding chapters. This chapter looks at some of these leftover topics, including probability, permutations and combinations, and factorials. The topics in this chapter are not essential to your GRE Math score, because these areas are not tested as frequently as the topics detailed earlier. However, if you feel confident with the previous math topics, and you're looking to maximize your GRE Math score, this chapter will show you all you need to know to tackle these more obscure GRE problems.

OTHER MATH TOPICS

The bulk of the GRE Math section tests your knowledge of fundamentals, basic algebra, and geometry. However, there are a few other topics that may appear. These “et cetera” concepts usually show up only once or twice per test (although at higher scoring levels they may appear more frequently) and often cause anxiety among test takers. Many test takers worry excessively about probability problems, for example, even though knowledge of more familiar topics such as fractions and percents will be far more important in determining your GRE math score. So tackle these problems only after you’ve mastered the rest. If you find these concepts more difficult, don’t worry—they won’t make or break your GRE score.

These topics show up rarely on the GRE, but if

you're going for a very
high score, they are useful
to know.

PROBABILITY

If you flip a coin, what's the probability that it will land heads up? The probability is equal to one out of two, or $\frac{1}{2}$. What is the probability that it won't land heads up? Again, one out of two, or $\frac{1}{2}$. If you flip a coin nine times, what's the probability that the coin will land on heads on the tenth flip? Still 1 out of 2, or $\frac{1}{2}$. Previous flips do not affect the outcome of the current coin flip.

You can think of probability as just another type of fraction. **Probabilities** express a special relationship, namely the chance of a certain outcome occurring. In a probability fraction, the denominator is the total number of possible outcomes that may occur, while the numerator is the number of outcomes that would satisfy the criteria. For example, if you have 10 shirts and 3 of them are black, the probability of selecting a black shirt from your closet without looking is $\frac{3}{10}$.

Since probability is expressed as a fraction, it can also be expressed as

9/1/2017
a decimal or a percentage.
A probability of one half is
equivalent to a probability
of 0.5 or 50%.

Think of probability in terms of fractions:

- If it is impossible for something to happen—if no outcomes satisfy the criteria—then the numerator of the probability fraction is 0 and the probability is equal to 0.
- If something is certain to happen—if all possible outcomes satisfy the criteria—then the numerator and denominator of the fraction are equal and the probability is equal to 1.
- If it is possible for something to occur, but it will not definitely occur, then the probability of it occurring is between 0 and 1.

$$\text{probability} = \frac{\text{number of possible outcomes that satisfy the condition}}{\text{number of total possible outcomes}}$$

Let's see how it works.

At a meeting of 375 members of a neighborhood association, $\frac{1}{5}$ of the participants have lived in the community for less than 5 years and $\frac{2}{3}$ of the attendees have lived in the neighborhood for at least 10 years. If a member of the meeting is selected at

random, what is the probability that the person has lived in the neighborhood for at least 5 years but less than 10 years?

- $\frac{2}{15}$
- $\frac{3}{10}$
- $\frac{4}{15}$
- $\frac{1}{2}$
- $\frac{8}{15}$

Here's How to Crack It

In order to solve this problem, we need to put together our probability fraction. The denominator of our fraction is going to be 375, the total number of people from which we are selecting. Next we need to figure out how many attendees satisfy the criteria of having lived in the neighborhood for more than 5 years but fewer than 10 years.

What number goes on the bottom of the probability fraction?

First, we know that $\frac{1}{5}$ of the participants have lived in the neighborhood for less than 5 years. $\frac{1}{5}$ of 375 is 75 people, so we can take them out of the running. Also, $\frac{2}{3}$ of the

attendees have lived in the neighborhood for at least 10 years. $\frac{2}{3}$ of 375 (be careful not to use 300 as the total!) is 250, so we can also remove them from consideration. Thus, if 75 people have lived in the neighborhood for less than 5 years and 250 have lived for at least 10, the remaining people are the ones we want. $250 + 75$ is 325, so that leaves us with 50 people who satisfy the criteria. We need to make 50 the numerator of our fraction, which gives us $\frac{50}{375}$. This reduces to $\frac{2}{15}$, and answer choice (A) is the best answer.

Two Important Laws of Probability

When you want to find the probability of a series of events in a row, you multiply the probabilities of the individual events. What is the probability of getting two heads in a row if you flip a coin twice? The probability of getting a head on the first flip is $\frac{1}{2}$. The probability is also $\frac{1}{2}$ that you'll get a head on the second flip, so the combined probability of two heads is $\frac{1}{2} \times \frac{1}{2}$, which equals $\frac{1}{4}$. Another way to look at it is that there are four possible outcomes: HH, TT, HT, TH.

Only one of those outcomes consists of two heads in a row. Thus, $\frac{1}{4}$ of the outcomes consist of two heads in a row. Sometimes the number of outcomes is small enough that you can list them and calculate the probability that way.

$$\begin{aligned} \text{Probability of A and B} \\ &= \text{Probability of A} \\ &\times \text{Probability of B} \end{aligned}$$

Occasionally, instead of finding the probability of one event AND another event happening, you'll be asked to find the probability of either one event OR another event

happening. In this situation, instead of multiplying the probabilities, you add them.

Let's say you have a normal deck of 52 cards.

If you select a card at random, what's the probability that you select a 7 or a 4? The

probability of selecting a 7 is $\frac{4}{52}$, which re-

duces to $\frac{1}{13}$. The probability of selecting a 4

is the same; $\frac{1}{13}$. Therefore the probability of

selecting a 7 or a 4 is $\frac{1}{13} + \frac{1}{13} = \frac{2}{13}$.

Probability of A or B
= Probability of A
+ Probability of B

Let's look at a problem:

When a pair of six-sided dice, each with faces numbered 1 to 6, is rolled once, what is the probability that the result is either a 3 and a 4 or a 5 and a prime number?

Give your answer as a fraction.

Click on each box and type in a number.

Backspace to erase.

Here's How to Crack It

Probability is fundamentally about counting. You need to be able to count all the things that can happen and count all the situations

that meet the conditions of the problem. Sometimes, the easiest way to count both everything that can happen and the situations that meet the condition is to write everything out. In this case, let's use a table:

	1	2	3	4	5	6
1	✗	✗	✗	✗	✗	✗
2	✗	✗	✗	✗	✓	✗
3	✗	✗	✗	✓	✓	✗
4	✗	✗	✓	✗	✗	✗
5	✗	✓	✓	✗	✓	✗
6	✗	✗	✗	✗	✗	✗

Each cell of this table represents a result when the dice are rolled. For example, the cell at the intersection of the row shown as 1 and the column shown as 1 would represent that 1 was showing on each of the two die. This cell has been marked with an ✗ because it does not meet either condition of the problem.

The cells marked with a ✓ are the only dice rolls that meet one of the conditions of the problem. To finish, just count the ✓ marks—there are 7. (Remember that 1 is not prime. That's why combinations such as 5 and 1 are not checked.) Next, count the total possibilities—there are 36. So, the probability of rolling either a 3 and a 4 or a 5 and prime number is $\frac{7}{36}$.



One last important thing you should know about probabilities is that the probability of

an event happening and the probability of an event not happening must add up to 1. For example, if the probability of snow falling on one night is $\frac{2}{3}$, then the probability of no snow falling must be $\frac{1}{3}$. If the probability that it will rain is 80%, then the probability that it won't rain must be 20%. The reason this is useful is that, on some GRE probability problems, it will be easier to find the probability that an event doesn't occur; once you have that, just subtract from 1 to find the answer.

Let's look at the following example.

Since probabilities are just fractions, they can also be expressed as percents.

Dipak has a 25% chance of winning each hand of blackjack he plays. If he has \$150 and bets \$50 a hand, what is the probability that he will still have money after the third hand?

- $\frac{1}{64}$
- $\frac{3}{16}$
- $\frac{27}{64}$
- $\frac{37}{64}$

$$\circ \frac{3}{4}$$

Here's How to Crack It

If Dipak still has money after the third hand, then he must have won at least one of the hands, and possibly more than one. However, directly calculating the probability that he wins at least one hand is tricky because there are so many ways it could happen (for example, he could lose-lose-win, or W-W-L or W-L-W or L-W-L, and so on). So think about it this way: The question asks for

the probability that he will win at least one hand. What if he doesn't? That would mean that he doesn't win any hands at all. If we calculate the probability that he loses every hand, we can then subtract that from 1 and find the corresponding probability that he wins at least one hand. Since Dipak has a 25% chance of winning each hand, this means that he has a 75% chance of losing it, or $\frac{3}{4}$ (the answers are in fractions, so it's best to work with fractions). To find the probability that he loses all three hands, simply multiply the probabilities of his losing each

individual hand. $\frac{3}{4} \times \frac{3}{4} \times \frac{3}{4} = \frac{27}{64}$ so there is a $\frac{27}{64}$ probability that he will lose all three

hands. Subtracting this from 1 gives you the answer you're looking for. $1 - \frac{27}{64} = \frac{37}{64}$.

The answer is (D).

Given events A and B, the probability of

- A and B = (Probability of A) \times (Probability of B)
- A or B = Probability of A + Probability of B - Probability of A and B

Given event A

- Probability of A + Probability of Not A = 1

FACTORIALS

The **factorial** of a number is equal to that number times every positive whole number smaller than that number, down to 1. For example, the factorial of 6 is equal to $6 \times 5 \times 4 \times 3 \times 2 \times 1$, which equals 720. The symbol for a factorial is ! so 4! doesn't mean we're really excited about the number 4, it means $4 \times 3 \times 2 \times 1$, which is equal to 24. (0! is equal to 1, by the way.) When factorials show up in GRE problems, always look for a shortcut like canceling or factoring. The point of a factorial problem is not to make you do a lot of multiplication. Let's try one.

Quantity A

Quantity B

$$\frac{12!}{11!}$$

$$\frac{4!}{2!}$$

- Quantity A is greater.
- Quantity B is greater.
- The two quantities are equal.
- The relationship cannot be determined from the information given.

Here's How to Crack It

Let's tackle Quantity A. We definitely don't want to multiply out the factorials since that would be pretty time-consuming: $12!$ and $11!$ are both huge numbers. Instead let's look at what they have in common. What we're

really talking about here is

$$\frac{12 \times 11 \times 10 \times 9 \times 8 \times 7 \times 6 \times 5 \times 4 \times 3 \times 2 \times 1}{11 \times 10 \times 9 \times 8 \times 7 \times 6 \times 5 \times 4 \times 3 \times 2 \times 1}$$

Now it's clear that both factorials share everything from 11 on down to 1. The entire bottom of the fraction will cancel and the only thing left on top will be 12, so the value of Quantity A is 12. For Quantity B, we can also write out the factorials and get

$$\frac{4 \times 3 \times 2 \times 1}{2 \times 1}$$

The 2 and the 1 in the bottom cancel, and the only thing left on top will be 4×3 , which is equal to 12. The two quantities are equal and the answer is (C).

PERMUTATIONS AND COMBINATIONS

The basic definition of a **permutation** is an arrangement of things in a particular order. Suppose you were asked to figure out how many different ways you could arrange five statues on a shelf. All you have to do is multiply $5 \times 4 \times 3 \times 2 \times 1$, or 120. (Yes, this is another application of factorials.) You have five possible statues that could fill the first slot on the shelf, then, once the first slot is filled, there are four remaining statues that could fill the second slot, three that could fill the third slot, and so on, down to one.

Permutation problems often ask for arrangements, orders, schedules, or lists.

Now suppose that there are five people running in a race. The winner of the race will get a gold medal, the person who comes in second will get a silver medal, and the person who comes in third will get a bronze medal. You're asked to figure out how many different orders of gold-silver-bronze winners there can be. (Notice that this is a permutation because the order definitely matters.)

First, ask yourself how many of these runners can come in first? Five. Once one of them comes in first, she's out of the picture, so how many can then come in second? Four. Once one of them comes in second, she's out of the picture, so how many of them can come in third? Three. And now you're done because all three slots have been filled. The answer is $5 \times 4 \times 3$, which is 60.

To solve a permutation

- Figure out how many slots you have.
- Write down the number of options for each slot.
- Multiply them.

The difference between a permutation and a combination is that in a combination, the order is irrelevant. A **combination** is just a group, and the order of elements within the group doesn't matter. For example, suppose you were asked to go to the store and bring home three different types of ice cream. Now suppose that when you got to the store, there were five flavors in the freezer—chocolate, vanilla, strawberry, butter pecan, and mocha. How many combinations of three ice cream flavors could you bring home? Notice

that the order doesn't matter, because bringing home chocolate, strawberry, and vanilla is the same thing as bringing home strawberry, vanilla, and chocolate. One way to solve this is the brute force method; in other words, write out every combination.

Combination problems usually ask for groups, teams, or committees.

VCS VCB VCM VSB VSM VBM CSB CSM
CBM SBM

That's 10 combinations, but there's a quicker way to do it. Start by filling in the three slots as you would with a permutation (there are three slots because you're supposed to bring home three different types of ice cream).

Five flavors could be in the first slot, four could be in the second, and three could be in the third. So far, that's $5 \times 4 \times 3$. But remember, this takes into account all the different orders that three flavors can be arranged in. We don't want that, because the order doesn't matter in a combination. So we have to divide $5 \times 4 \times 3$ by the number of ways of arranging three things. In how many ways can three things be arranged? That's $3!$, $3 \times 2 \times 1$, which is 6. Thus we end up with $\frac{5 \times 4 \times 3}{3 \times 2 \times 1}$, which is equal to $\frac{60}{6}$, or 10. Bingo.

Does the order matter?

To solve a combination

- Figure out how many slots you have.
- Fill in the slots as you would a permutation.
- Divide by the factorial of the number of slots.

The denominator of the fraction will always cancel out completely, so you can cancel first before you multiply.

Here's an example:

Always cross off wrong
answer choices on your
scratch paper.



Brooke wants to hang three paintings in a row on her wall. She has six paintings to choose from. How many arrangements of paintings on the wall can she create?

- 6
- 30
- 90
- 120
- 720

Here's How to Crack It

The first thing you need to do is determine whether the order matters. In this case it does, because we're arranging the paintings on the wall. Putting the Monet on the left and the Van Gogh in the middle isn't the same arrangement as putting the Van Gogh

on the left and the Monet in the middle. This is a permutation question. We have three slots to fill because we're arranging three paintings. There are 6 paintings that could fill the first slot, 5 paintings that could fill the second slot, and 4 paintings that could fill the third slot. So we have $6 \times 5 \times 4$, which equals 120. Thus, the correct answer is (D).



Here's another example:



A pizza may be ordered with any of eight possible toppings.

Quantity A

The number of
different ways to

Quantity B

The number of
different ways to

order a pizza
with three differ-
ent toppings

order a pizza
with five differ-
ent toppings

- Quantity A is greater.
- Quantity B is greater.
- The two quantities are equal.
- The relationship cannot be determined from the information given.

Here's How to Crack It

First, note that for both quantities we're dealing with a combination, because the order of toppings doesn't matter. A pizza with mushrooms and pepperoni is the same thing as a pizza with pepperoni and mushrooms. Let's figure out Quantity A first.

We have eight toppings and we're picking three of them. That means we have three slots to fill.

There are 8 toppings that could fill the first slot, 7 that could fill the second slot, and 6 that could fill the third, so we have $8 \times 7 \times 6$. Since this is a combination, we have to divide by the factorial of the number of slots. In this case we have three slots, so we have to divide by $3!$, or $3 \times 2 \times 1$. So

our problem looks like this: $\frac{8 \times 7 \times 6}{3 \times 2 \times 1}$. To make

the multiplication easier, let's cancel first. The 6 on top will cancel with the 3×2 on the bottom, leaving us with $\frac{8 \times 7}{1}$, which is 56. Thus, there

are 56 ways to order a three-topping pizza with

eight toppings to choose from. Now let's look at Quantity B.

We still have eight toppings, but this time we're picking five of them so we have five slots to fill.

There are 8 toppings that could fill the first slot, 7 that could fill the second slot, 6 that could fill the third, 5 that could fill the fourth, and 4 that could fill the fifth. That's $8 \times 7 \times 6 \times 5 \times 4$, but we still

have to divide by the factorial of the number of slots. We have five slots, so that means we need to divide by $5!$, or $5 \times 4 \times 3 \times 2 \times 1$. Thus we

have $\frac{8 \times 7 \times 6 \times 5 \times 4}{5 \times 4 \times 3 \times 2 \times 1}$. We definitely want to

cancel first here, rather than doing all that multiplication. The 5 on top will cancel with the 5 on the bottom. Likewise, the 4 on top will cancel with the 4 on the bottom. The 6 on top will cancel with the 3×2 on the bottom, leaving us again with $\frac{8 \times 7}{1}$, which is 56. Therefore, there are also 56 ways to order a five-topping pizza with eight toppings to choose from. The two quantities are equal, and the answer is (C).



Let's try one more:



Nicole needs to form a committee of 3 from a group of 8 research attorneys to study possible changes to the Superior Court. If two of the attorneys are too inexperienced to serve together on the committee, how many different arrangements of committees can Nicole form?

- 20
- 30
- 50
- 56
- 336

Here's How to Crack It

This problem is a little more complicated than an ordinary combination problem, because an extra condition has been placed on

the committee. Without that condition, this would be a fairly ordinary combination problem, and we'd simply calculate how many groups of three can be created with eight people to choose from.

There's more than one way to approach this problem. First, you should realize that there are two ways that we could form this committee. We could have three experienced attorneys, or we could have two experienced attorneys and one inexperienced attorney. If we find the number of ways to create each of those two possibilities, we can add them together and have our answer. It's fairly straightforward to calculate the number of

ways to have three experienced attorneys on a committee: There are three slots to fill, and we have 6 options for the first slot, 5 for the second, and 4 for the third. Here the order doesn't matter, so we divide by $3!$ to get $\frac{6 \times 5 \times 4}{3 \times 2 \times 1} = 20$. Thus there are 20 ways to create the committee using three experienced attorneys. What about creating a committee that has two experienced attorneys and one inexperienced attorney? We have 6 options for the first experienced attorney and 5 options for the second. Order doesn't matter so we divide by $2!$. So far we have

$\frac{6 \times 5}{2 \times 1}$. Next we have 2 options for the inex-

perienced attorney, so now we have to multiply by 2, and our calculation is $\frac{6 \times 5}{2 \times 1} \times \frac{2}{1} =$

30. As you can see, there are 30 ways to create the committee using two experienced attorneys and one inexperienced attorney. Adding 20 and 30 gives us 50 total committees, and the answer is (C).

Here's another way that you could solve the problem. If there were no conditions placed on the committee, we could just calculate $\frac{8 \times 7 \times 6}{3 \times 2 \times 1}$, which would give us 56

committees. But we know some of those committees are not allowed; any committee that has the two inexperienced attorneys on it isn't allowed. How many of these types of committees are there? Let's call the inexperienced attorneys A and B. An unacceptable committee would be A B __, in which the last slot could be filled by any of the experienced attorneys. Since there are 6 experienced attorneys, there are 6 unacceptable committees. Subtracting them from 56 gives us 50 acceptable committees. Hey, the answer's still (C)!



FUNCTIONS AND FUNNY-LOOKING SYMBOLS

Many GRE functions problems don't look like the functions that you learned in high school. While some GRE functions questions use the standard $f(x)$ function notation, many use funny looking symbols such as @, *, and #. Each symbol represents an arithmetic operation or a series of arithmetic operations. All you have to do is follow directions in the problem. Here's an example:

With funny-looking symbols, simply follow the directions.

For any non-negative integer x , let
 $x^* = x - 1$

Quantity A

$$\frac{15^*}{3^*}$$

Quantity B

$$\left(\frac{15}{3}\right)^*$$

- Quantity A is greater.
- Quantity B is greater.
- The two quantities are equal.
- The relationship cannot be determined from the information given.

Here's How to Crack It

Just follow the directions— $15^* = 15 - 1$, or 14, and $3^* = 3 - 1$, or 2. So we get $\frac{14}{2}$, or 7, in

Quantity A. Don't forget PEMDAS for

Quantity B. First, $\frac{15}{3}$ is 5. Then, $5^* = 5 - 1$, or

4. So because Quantity A is 7 and Quantity B is 4, the answer is (A). Function questions aren't scary if you follow the directions. Be sure to write everything down on your scratch paper. By the way, these funny-looking symbols don't necessarily indicate exponents, but you'll always be told what they mean.



GROUPS

Group problems, although not too common on the GRE, can be troublesome if you don't know how to set them up. When confronted by a group problem, use the group equation

$$T = G_1 + G_2 - B + N$$

You might see one group problem on the GRE.

In the equation, T represents the Total, G_1 is one group, G_2 is the second group, B is for the members in both groups and N is for the members in neither group. Here's an example of a typical group problem.

A biologist studying breeding groups noted that of 225 birds tagged for the study, 85 birds made nests in pine trees, 175 made nests in oak trees, and 40 birds did not build nests in either type of tree. How many birds built nests in both types of trees?

- 45
- 60
- 75
- 80
- 125



Wrapping Up Math

You're almost done with the Math section. Tackle

the Math Drills on the following pages, then give yourself a break before you dive into the Analytical Writing Section. Take a walk, eat a snack, or meet up with a pal and give yourself some downtime before you dive into [Part IV](#).

Here's How to Crack It

Let's use the group equation. The total is 225, one group consists of 85 birds, the other group has 175 birds in it, and we know that 40 birds built nests in neither type of tree. Our equation would look like this:

$$225 = 85 + 175 - B + 40$$

All we have to do is solve for B. Simplifying the equation gives us $225 = 300 - B$, so B must equal 75. Choice (C) is our answer.



Et Cetera Drill

Here are some math questions to practice on. Remember to check your answers when you finish. You can find the answers in [Part V](#).

1 of 10

A bowl contains 15 marbles, all of which are either red or blue. If the number of red marbles is one more than the number of blue marbles, what is the probability that a marble selected at random is blue?

$\frac{1}{15}$

- $\frac{2}{15}$
- $\frac{7}{15}$
- $\frac{1}{2}$
- $\frac{8}{15}$

2 of 10

If $\forall(x) = 10x - 1$, what is $\forall(5) - \forall(3)$?

- 15
- 18
- 19
- 20
- 46

3 of 10

Quantity A

Quantity B

The greatest odd factor of 78

The greatest prime factor of 78

- Quantity A is greater.
- Quantity B is greater.
- The two quantities are equal.
- The relationship cannot be determined from the information given.

4 of 10

At a recent dog show, there were 5 finalists. One of the finalists was awarded “Best in Show” and another finalist was awarded “Honorable

Mention.” In how many ways could the two awards be given out?

Click on the answer box and type in a number.

Backspace to erase.

5 of 10

Company X budgets \$90,000 total on advertising for all of its products per year. Company X budgets \$40,000 for all advertising for product A and \$30,000 for all advertising for product B . From the budgets for products A and B , \$15,000 is budgeted for advertisements that feature both products used as a system.

Quantity A

Quantity B

The total amount
Company X
budgets for ad-
vertising $\$20,000$
products other
than products A
and B .

- Quantity A is greater.
- Quantity B is greater.
- The two quantities are equal.
- The relationship cannot be determined from the information given.

[6](#) of 10

Lee randomly selects a 2-digit prime number less than 50. What is the probability that the tens digit is greater than the units digit?

- $\frac{3}{14}$
- $\frac{3}{11}$
- $\frac{3}{8}$
- $\frac{1}{2}$
- $\frac{8}{11}$

[7](#) of 10

An elected official wants to take five members of his staff to an undisclosed secure location. How many staff members must the elected official employ in order to have a minimum of 20 different groups from which to choose?

- 7
- 8
- 9
- 10
- 11

8 of 10

For all real numbers x and y , if $x \# y = x(x - y)$, then $x \# (x \# y) =$

- $x^2 - xy$
- $x^2 - 2xy$
- $x^3 - x^2 - xy$
- $x^3 - (xy)^2$
- $x^2 - x^3 + x^2y$

9 of 10

A jar contains 12 marbles. Each is either yellow or green and there are twice as many yellow marbles as green marbles. If two marbles are to be selected from the jar at random, what is the probability that exactly one of each color is selected?

$\frac{8}{33}$

$\frac{16}{33}$

$\frac{1}{2}$

$\frac{17}{33}$

$\frac{25}{33}$

A set of 10 points lies in a plane such that no three points are collinear.

Quantity A

The number of distinct triangles that can be created from the set

Quantity B

The number of distinct quadrilaterals that can be created from the set

- Quantity A is greater.
- Quantity B is greater.
- The two quantities are equal.
- The relationship cannot be determined from the information given.

Comprehensive Math Drill

Let's do a drill involving all of the math topics we have covered throughout the book. Remember to check your answers when you finish. You can find the answers in [Part V](#).

1 of 20

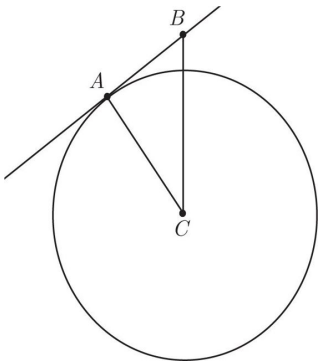

Line AB is tangent to the circle C at point A . The radius of the circle with center C is 5 and $BC = \frac{10\sqrt{3}}{3}$.

Quantity A

Quantity B

The length of line segment AB

The length of line segment AC

- Quantity A is greater.
- Quantity B is greater.
- The two quantities are equal.
- The relationship cannot be determined from the information given.

Quantity A

$$\frac{x}{10}$$

Quantity B

$$\frac{\frac{x}{5}}{2}$$

- Quantity A is greater.
- Quantity B is greater.
- The two quantities are equal.
- The relationship cannot be determined from the information given.

3 of 20

The test scores for a class have a normal distribution, a mean of 50, and a standard deviation of 4.

Quantity A**Quantity B**

Percentage of
scores at or
above 58

Percentage of
scores at or be-
low 42

- Quantity A is greater.
- Quantity B is greater.
- The two quantities are equal.
- The relationship cannot be determined from the information given.

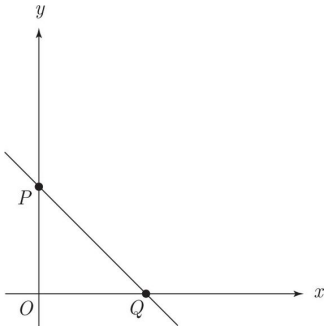

The line $y = -\frac{5}{6}x + 1$ is graphed on the rectangular coordinate axes.

Quantity A

Quantity B

OQ

OP

- Quantity A is greater.
- Quantity B is greater.
- The two quantities are equal.

- The relationship cannot be determined from the information given.

5 of 20

At a dog show, there are 20 judges and 10 dogs in the final round.

Quantity A

The number of distinct pairs of judges

Quantity B

The number of possible rankings of dogs from first to third place

- Quantity A is greater.
- Quantity B is greater.
- The two quantities are equal.
- The relationship cannot be determined from the information given.

6 of 20

$$k > 0$$

$$l > 1$$

Quantity A

$$\frac{1}{\frac{1}{k} + \frac{1}{l}}$$

Quantity B

$$\frac{kl}{\frac{1}{k} + \frac{1}{l}}$$

- Quantity A is greater.
- Quantity B is greater.
- The two quantities are equal.
- The relationship cannot be determined from the information given.

7 of 20

A jeweler made a profit of \$800 on the discounted price of a diamond

that cost the jeweler \$5,400 to purchase. The profit from the discounted price is 80% less than the profit the jeweler would have made if he sold the diamond for its regular, undiscounted price.

Quantity A

The profit the jeweler would have made from the regular, undiscounted price of the diamond expressed as a percentage of the price for which the jeweler bought the diamond.

Quantity B

The difference between the profit on the discounted price and the profit on the regular, undiscounted price expressed as a percentage of the original price.

- Quantity A is greater.

- 10/30/1807
- Quantity B is greater.
 - The two quantities are equal.
 - The relationship cannot be determined from the information given.

[8](#) of 20

Joe has \$200. If he buys a CD player for \$150, what is the greatest number of CDs he can buy with the remaining money if CDs cost \$12 each?

Click on the answer box and type in a number.

Backspace to erase.

[9](#) of 20

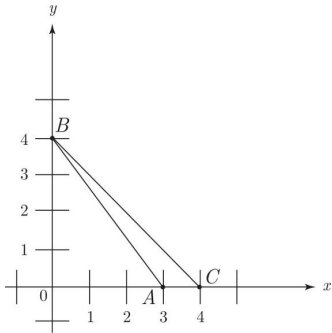

What is the area of triangle ABC in the figure above?

- 2
- 4
- $4\sqrt{2}$
- 7
- 8

By which of the following could $10(9^6)$ be divided by to produce an integer result?

Indicate all such values.

90

100

330

540

720

[11](#) of 20

Roberta drove 50 miles in 2 hours. Her rate in miles per hour is equivalent to which of the following proportions?

Indicate all such proportions.

5 to 20

100 to 4

400 to 16

20 to 500

520 to 20

Questions 12 through 14 refer to the following graph.

TEMPERATURES OF U.S. CITIES IN
YEARS X AND Y

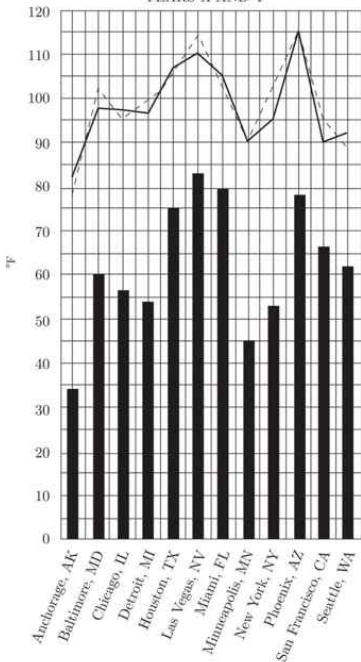

- Average Temperature for Years X and Y
- High for Year Y
- High for Year X

[12](#) of 20

For how many of the cities shown was the highest temperature in Year Y greater than or equal to the highest temperature in Year X ?

- 4
- 5
- 7
- 8
- 12

[13](#) of 20

What is the approximate percent increase from the lowest average (arithmetic mean) temperature for Years X and Y to the highest average temperature?

- 60%
- 82%
- 140%
- 188%
- 213%

[14](#) of 20

The average (arithmetic mean) temperature for any city in Years X and Y is the average of the high and low temperatures for those years. What is the average low temperatures for Baltimore for Years X and Y ?

- -9° F
- 11° F
- 20° F
- 44° F

- It cannot be determined from the information given.

[15](#) of 20

If $|2x - 3| + 2 > 7$, which of the following could be the value of x ?

Indicate all such values.

-4

-3

-2

-1

0

1

2

3

16 of 20

If x , y , and z are consecutive odd integers where $x < y < z$ and $x + y + z < z$, then which of the following could be the value of x ?

Indicate all such values.

-3

-1

0

1

3

17 of 20

If $4^x = 1,024$, then $(4^{x+1})(5^{x-1}) =$

10^6

$(5^4)(10^5)$

- $(4^4)(10^5)$
- $(5^4)(10^4)$
- $(4^4)(10^4)$

[18](#) of 20

What is the greatest distance between two vertices of a rectangular solid with a height of 5, a length of 12, and a volume of 780 ?

- 12
- $12\sqrt{2}$
- 13
- $13\sqrt{2}$
- $13\sqrt{3}$

[19](#) of 20

Six children, three boys and three girls, sit in a row on a park bench. How many arrangements of children are possible if no boy can sit on either end of the bench?

Indicate all such values.

46,656

38,880

1,256

144

38

[20](#) of 20

If 16 is the average (arithmetic mean) of p , 24, and q , what is $16(p + q)$?

180

- 192
- 384
- 524
- 768

Summary

- Topics such as probability, permutations and combinations, factorials, and functions represent only a small percentage of the math topics tested on the GRE. Make sure you've mastered all the more important topics before attempting these.
- Probability is expressed as a fraction. The denominator of the fraction represents the total number of possible outcomes, while the numerator stands for the desired outcomes.
- If a probability question asks for the chance of event A or event B, find the probability of each event and add them together. If the question asks

for the probability of event A and event B, multiply the individual probabilities.

- The key to factorial problems is to look for ways to cancel or factor out terms.
- Permutations and combinations are related concepts. A permutation tells you how many arrangements or orderings of things are possible. A combination tells you how many groupings of things are possible.
- Function problems use funny looking symbols as shorthand for the operations to perform on a certain number.
- The group equation is $\text{Total} = \text{Group}_1 + \text{Group}_2 - \text{Members of Both Groups} + \text{Members of Neither Group}$.

Part IV

How to Crack the Analytical Writing Section

[14 The Geography of the Analytical Writing Section](#)

[15 The Issue Essay](#)

[16 The Argument Essay](#)

Chapter 14

The Geography of the Analytical Writing Section

This chapter clues you in on everything you've ever wanted to know about the Analytical Writing section of the GRE. It contains important information on how the essays are used by graduate schools, the scoring system ETS graders use to evaluate your essays, and the crucial distinctions between the issue essay and the argument essay. This chapter also looks at the basic word-processing program used by ETS.

ESSAYS AND THE GRE

The Analytical Writing section of the GRE requires you to write two essays—one will be an analysis of an issue and the other will be an analysis of an argument. You will have 30 minutes for each essay.

In the past, ETS has had problems with test takers relying on preplanned essays. The essay questions have been reformulated to reduce the possibility of testers preparing their essays in advance. However, while you may not be able to plan your entire essay in advance, you can still go into your test session having a good idea of what type of essay you're going to write.

How Do Schools Use the Writing Assessment?

First, the essays are probably more important for international students and those for whom English is not a first language. If you are not a native English speaker, expect your essay score and the essays you wrote to receive more attention. (ETS also makes the essays available to schools, which may choose to read them or not.) Second, and not surprisingly, the essays will probably be weighted more heavily by programs for which writing is a frequent and necessary task. A master's program in applied mathematics might not care so much about your 30-minute written opinion about whether or not it's necessary for a person to read imaginative literature, but a program in creative writing probably would.

Even if your program doesn't care much for the

essay, a poor score might still raise a red flag.

Ultimately, though, here's the most honest answer to this question: It depends. Some schools will not care at all about the Analytical Writing score, while others will say that they want only applicants who scored a 5 or higher on this section. Call the schools you're interested in and talk to people in the department. By finding out how important your target schools consider the Analytical Writing section, you'll be able to determine the appropriate amount of effort to devote to it.



More Online!

Head over to
PrincetonReview.com/gre

1000/1507
for useful information
and helpful articles about
graduate school.

Regardless of your target score on this section, you should at least read through these chapters to get a better sense of what ETS is looking for. You'll have to write these essays, so no matter what, you want to do a decent job. You'll find that writing high-scoring essays is not as hard as it may seem once you've been shown how to do it.

How Will the Essays Be Scored?

Your essays will be read by two graders, and each will assign a score from 1 to 6, based on how well you do the following:

- follow the instructions of the prompt

- consider the complexities of the issue or argument
- effectively organize and develop your ideas
- support your position with relevant examples
- control the elements of written English

What you write—the content—will be weighted more than how you write.

The grades you receive for each essay will be totaled and averaged. For example, if you receive a 4 and a 5 on your issue essay and a 3 and a 4 on your argument essay, your Analytical Writing score will be a 4.0; 16 total points divided by 4 scores. If the graders' scores for your essays differ by more than one point, a third person will be brought in to read the essay. The graders use a holistic

grading system; they're trained to look at the big picture, not to focus on minor details. Your essay is not expected to be perfect, so the graders will overlook minor errors in spelling, punctuation, and grammar. However, pervasive or egregious errors will affect your score.

Here are ETS's descriptions of the scoring levels:

Issue Essay	
6	An essay that scores a 6 presents a cogent, well-articulated critique of the issue and conveys meaning skillfully.
5	An essay that scores a 5 presents a generally thoughtful, well-developed analysis of the complexities of the issue and conveys meaning clearly.
4	An essay that scores a 4 presents a competent analysis of the issue and conveys meaning adequately.
3	An essay that scores a 3 demonstrates some competence in its analysis of the issue and in conveying meaning but is obviously flawed.
2	An essay that scores a 2 demonstrates serious weaknesses in analytical writing.
1	An essay that scores a 1 demonstrates fundamental deficiencies in analytical writing skills.

Argument Essay	
6	An essay that scores a 6 presents a cogent, well-articulated critique of the argument and conveys meaning skillfully.
5	An essay that scores a 5 presents a generally thoughtful, well-developed critique of the argument and conveys meaning clearly.
4	An essay that scores a 4 presents a competent critique of the argument and conveys meaning adequately.
3	An essay that scores a 3 demonstrates some competence in its critique of the argument and in conveying meaning but is obviously flawed.
2	An essay that scores a 2 demonstrates serious weaknesses in analytical writing.
1	An essay that scores a 1 demonstrates fundamental deficiencies in both analysis and writing.

An essay written on a topic other than the one provided will receive a score of 0.

Who Are These Readers Anyway?

We'll put this in the form of a multiple-choice question:

Your essays will initially be read by

- (A) captains of industry
- (B) leading professors
- (C) college TAs working part time

If you guessed (C), you're correct. Each essay will be read by part-time employees of ETS, mostly culled from graduate school programs.

How Much Time Do They Devote to Each Essay?

The short answer is this: not much. It is unusual for a grader to spend more than two minutes grading an essay, and some essays are graded in less than a minute. The graders are reading many, many GRE essays and they aren't going to spend time admiring that clever turn of phrase you came up with. So don't sweat the small stuff—it probably won't even be noticed. Focus on the big picture—that's what the graders will be focusing on.

ETS graders spend less than two minutes grading your essay.

So How Do You Score High on the Analytical Writing Essays?

On the face of it, you might think it would be pretty difficult to impress these jaded readers, but it turns out that there are some very specific ways to persuade them of your superior writing skills.

Make the graders' jobs easy. Give them exactly what they're looking for.

What ETS Doesn't Want You to Know

In a recent analysis of a group of essays written by actual test takers, and the grades that those essays received, ETS researchers noticed that the most successful essays had one

thing in common. Which of the following characteristics do you think it was?

- Good organization
- Proper diction
- Noteworthy ideas
- Good vocabulary
- Sentence variety
- Length

What Your Essay Needs in Order to Look Like a Successful Essay

The ETS researchers discovered that the essays that received the highest grades from ETS essay graders had one single factor in common: length.

To ace the Analytical Writing section, you need to take one simple step: Write as much as you possibly can. Each essay should

include *at least* four indented paragraphs. Your Issue essay should be 400 to 750 words in length, and your Argument essay should be 350 to 600 words.

So All I Have to Do Is Type “I Hate the GRE” Over and Over Again?

Well, no. The length issue isn't that easy. The ETS researchers also noted that, not surprisingly, the high-scoring essays all made reasonably good points addressing the topic. So you have to actually write something that covers the essay topic. And in your quest for length, it's more important that you add depth than breadth. What this means is that it's better to have a few good examples that are thoroughly and deeply explored than it is to add length by tacking more and more examples and paragraphs onto your essay until it starts to feel like a superficial list of

bulleted points rather than a thoughtful piece of writing.

Read the Directions Every Time

You should read the directions for each essay prompt. The instructions we provide here for each essay task are not necessarily the ones you will see on the GRE. Directions can vary in focus, so you shouldn't memorize any particular set of instructions. Visit the ETS website at www.gre.org for a complete list of all the potential essay topics and direction variants. (Yes, you really get to see this information in advance of the test!) Practice responding to the different instructions, combined with a variety of issue and argument prompts. Be sure to mix it up; the prompt/directions pairings you see on the ETS website are not necessarily the duos you will see on the real test. Practicing with a

variety of these essays will prepare you for whatever comes your way on test day.

Oh, Yes, You Can Plan Your Essays in Advance

In fact, there are some very specific ways to prepare for the essays that go beyond length and good typing skills. So how can you prepare ahead of time?

Creating a Template

When a builder builds a house, the first thing he does is construct a frame. The frame supports the entire house. After the frame is completed, he can nail the walls and windows to the frame. We're going to show you how to build the frame for the perfect GRE essay. Of course, you won't know the exact topic of the essay until you get there (just as the builder may not know what color his

client is going to paint the living room), but you will have an all-purpose frame on which to construct a great essay no matter what the topic is. We call this frame the template.

Preconstruction

Just as a builder can construct the windows of a house in his workshop weeks before he arrives to install them, so can you pre-build certain elements of your essay. We call this “preconstruction.”

In the next two chapters we’ll show you how to prepare ahead of time to write essays on two topics that you won’t see until they appear on your screen.

ISSUE VERSUS ARGUMENT ESSAY

It is worth noting at this time that the essay section gives you two very distinct writing tasks, and that a failure to appropriately address the question tasks will severely reduce your score.

The Issue Essay

The Issue essay asks for your opinion; you're expected to present your viewpoint on a particular topic and support that viewpoint with various examples. The following is one example of the instructions for the Issue essay:

You will be given a brief quotation that states or implies an issue of general interest and specific instructions

on how to respond to that issue. You will have 30 minutes to plan and compose a response in which you develop a position on the issue according to the specific instructions. A response to any other issue will receive a score of zero.

Make sure that you respond to the specific instructions and support your position on the issue with reasons and examples drawn from such areas as your reading, experience, observations, and/or academic studies.

Note how important it is to specifically address the assignment provided as part of the Issue prompt; not following ETS's directions will make your grader unhappy and result in a poor score on the essay.

The Argument Essay

The Argument essay requires a different type of response. Instead of presenting your own perspective, your job is to critique someone else's argument. You're supposed to address the logical flaws of the argument, not provide your personal opinion on the subject. The following is one example of the directions for the Argument essay:

You will be given a short passage that presents an argument, or an argument to be completed, and specific instructions on how to respond to that passage. You will have 30 minutes to plan and compose a response in which you analyze the passage according to the specific instructions. A response to any other argument will receive a score of zero.

Note that you are NOT being asked to present your own views on the subject. Make sure that you respond to the specific instructions and support your analysis with relevant reasons and/or examples.

In the Argument essay, the emphasis is on writing a logical analysis of the argument, not an opinion piece. It is absolutely essential that you don't confuse the two essay tasks on the GRE.

ETS graders don't expect a perfect essay; occasional spelling, punctuation, and grammar errors won't kill your score.

HOW DOES THE WORD-PROCESSING PROGRAM WORK?

ETS has created a very simple program that allows students to compose their essays on the screen. Compared to any of the commercial word-processing programs, this one is extremely limited, but it does allow the basic functions: You can move the cursor with the arrow keys, and you can delete, copy, and paste. You don't have to use any of these functions. With just the backspace key and the mouse to change your point of insertion, you will be able to use the computer like a regular word-processing program.

Take a look at the image below to see what your screen will look like during the Analytical Writing section of the test:

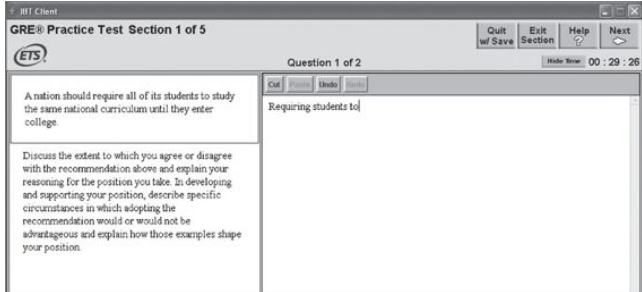

The question will always appear at the top left of your screen. Beside it, in a box, will be your writing area (in the writing area above, you can see a partially completed sentence). When you click inside the box with your mouse, a winking cursor will appear, indicating that you can begin typing.

As we said above, the program supports the use of many of the normal computer keys:

- The “Backspace” key removes text to the left of the cursor.
- The “Delete” key removes text to the right of the cursor.
- The “Arrow” keys move the cursor up, down, left, or right.
- The “Home” key moves the cursor to the beginning of a line.
- The “End” key moves the cursor to the end of a line.
- The “Enter” key moves the cursor to the beginning of the next line.
- “Page up” moves the cursor up one page.
- “Page down” moves the cursor down one page.

You can also use the buttons above the writing area to copy and paste words, sentences, or paragraphs. To do this, you first have to highlight the desired text by clicking on the starting point with your mouse and holding down the mouse button while you drag it to the ending point. Then click on the “Cut” button. This deletes the text you’ve selected from the screen, but also stores it in the computer’s memory. Next, just move the cursor to wherever you would like the selected text to reappear, and click on the “Paste” button. The selected text will appear in that spot.

If you make a mistake, simply click on the “Undo” button, which will undo whatever operation you have just done. You can undo a cut, a paste, or even the last set of words you’ve typed in. Unfortunately, unlike many word-processing programs, ETS’s program does not have a “Redo” button, so be careful what you decide to undo.

Obviously, the small box on the screen is not big enough to contain your entire essay. However, by hitting the “Page up” and “Page down” keys on your keyboard, or by using the arrows on your keyboard, you will be able to go forward and backward to reread what you have written and make corrections.

Does Spelling Count?

Officially, no. The word-processing program doesn't have a spell checker, and ETS essay readers are supposed to ignore minor errors of spelling and grammar, but the readers wouldn't be human if they weren't influenced by an essay that had lots of spelling mistakes and improper grammar—it gives the impression that you just didn't care enough to proofread.

Because pervasive spelling errors will detract from your score, pick an easier word if you're really uncertain of how to spell a word.

Summary

- Different programs value the essay section in different ways. Check with your program to see how important the essays are.
- Understand the criteria ETS uses for judging your essay. Organization, examples, and language use are important. Perfect grammar and spelling less so.
- On the GRE, longer essays tend to receive better scores, so strive to write as much as you can for each essay.
- Make sure you understand the differences in the assignments for the Issue essay and the Argument essay.

- Issue essays ask for your opinion on a topic while Argument essays expect you to critique the logic of an argument. The ways in which you're asked to do each of these tasks will vary, so make sure you read each set of directions carefully.
- The word processor ETS provides has only the most basic functions. You can delete, copy, and paste text, but not much more.

Chapter 15

The Issue Essay

The Issue essay of the GRE requires you to present your opinion on the provided topic. This chapter will show you the steps to take in order to write a clear, coherent essay in the limited time provided. You'll learn exactly what sort of things the ETS graders are looking for when they evaluate your essay so you'll know just what to do on test day.



THREE BASIC STEPS

Because you don't have a lot of time to write the essays, you'll need to have a pretty good idea of how you're going to attack them as soon as you sit down at the computer on test day. Our approach to the essays involves three steps:

1. **Think.** Before you start writing, take a moment to brainstorm some thoughts about the topic.
2. **Organize.** Take the ideas you've come up with and fit them into the assignment for the prompt.
3. **Write.** Once you've completed the first two steps, the final step should be a snap.

Thirty minutes is not a lot of time to write an essay, so you have to get it right the first time

out. While ETS advises you to leave enough time to proofread and edit your essay, it simply isn't feasible to expect to make any significant changes to your essay during the final minutes of the section. Furthermore, if you get halfway through your essay and realize you're stuck or you're not saying what you need to say, you'll be hard pressed to fix your essay in the time you have left.

You have to know what you want your essay to say before you can start writing.

It is essential, therefore, to make sure you spend time planning your essay before you start writing. You have to figure out what it is you want to say before you begin; otherwise, you run the risk of writing an incoherent, rambling essay. The first two steps are actually more important to a successful GRE essay than the final step; by spending a little

time planning your essay, the actual writing part should be relatively painless.

The keys to the essay: Think, Organize,
Write

Let's start our discussion of the Issue essay by looking at a typical prompt.

The Prompt

“True beauty is found not in the exceptional but in the commonplace.”

Write an essay in which you take a position on the

statement above. In developing and supporting your essay, consider instances in which the statement does and does not hold true.

The prompts are supposed to get you thinking about areas of “general interest,” whatever that means. A better way of thinking about the prompt is to look at it as an agree/disagree or pro/con statement. Your task in the essay will be to look at both sides of the issue, the pro and the con side, and take a position on the statement. Let’s look at how to do that.

Step 1

STEP 1: THINK

“Think” is a pretty broad command, so we need to clarify this step in order to make it more useful. Specifically, we want you to think about three things:

1. **Key Terms.** What are the key words or phrases in the prompt? Do the terms need clarifying before you can properly deal with them in the essay?
2. **Opposite Side.** What would the converse of the statement be?
3. **Examples.** What are some examples that would support the statement? What are some examples that would support the opposite statement?

Let’s work through these steps with our sample prompt.

Key Terms

When preparing your essay, first look more closely at the key terms in the prompt. Do they need to be clarified? Are there multiple ways of interpreting the words? In order to make your essay as focused as possible, you might need to limit the key terms to a specific definition or interpretation. If the key terms in the prompt seem pretty straightforward, you still want to note them. By repeatedly returning to these terms in your essay, you'll convey the impression that your essay is strongly organized and on topic.

Write down the key terms.

For this prompt, the key terms are *beauty*, *true*, *exceptional*, and *commonplace*. We need to think about how we're going to use these terms in our essay. For example, what is *true beauty*? Do we want that to mean just natural beauty or can we consider man-made

objects? As for the word *beauty*, do we want to limit our discussion to artistic beauty such as paintings and sculptures, or should we consider poems and literature as well? Should we discuss only natural beauty, such as stars and flowers, or should we consider personal beauty as well, such as models and GRE instructors? As you can see, we could write a lot on this topic, if we had the time. But we don't, so it's important to focus. By defining our key terms, we make the essay a lot more manageable and easier to write in a short amount of time. For this essay, let's include both natural objects and man-made artistic feats, but leave out personal beauty.

Using key terms from the prompt throughout your essay contributes to its overall coherency.

Opposite Side

In order to score well on the Issue essay, you'll have to consider both sides of the prompt. ETS is looking for more than a straightforward "I agree and here's why" or "I disagree and here's why" essay. Rather, the graders want to see you consider both sides of the issue and then defend your position. Take a brief moment to look at the sample prompt again, and then write down the converse of the statement.

"True beauty is found not in the exceptional but in the commonplace."

For this prompt, the opposite side of the argument would be something along the lines of "True beauty is found not in the

commonplace, but in the exceptional.” Note that ETS doesn’t have a preference for the pro or con side. So if you find the opposite of the statement more convincing, that’s fine. As long as you can support your position with some relevant examples, it doesn’t matter what position you take on the prompt. This brings us to the final part of step one—brainstorming examples.

Examples

In many ways, the examples will be the most important part of your essay. Without strong, relevant examples you cannot expect to achieve a high score on the Issue essay. As the instructions state, you should support your position with examples drawn from your reading, experience, observation, and academic studies. In general, the more specific your examples are, the better your essay score. And examples from history, literature,

or current events are better than personal observations or experiences. Imagine yourself as an ETS grader (a terrible thought, we know). Which sentence would you respond more favorably to?

“Few observers would doubt the awesome beauty of the ceiling of the Sistine Chapel in Rome, a work of art produced by the great Renaissance artist Michelangelo.”

“Few observers would doubt the awesome beauty of the various paintings they see in museums, works of art produced by great artists.”

Both sentences essentially say the same thing and use practically the same words. But the first sentence would be graded more favorably by an ETS grader because of the specificity of the example.

Take a moment to jot down some examples for the previous prompt. Make sure you come up with examples for both the original statement and its opposite.

Now take a moment to look over your examples. Are they specific? Are they relevant to the topic? Do they support a position on the topic? The strength of your examples will determine the strength of your argument. It's hard to write a convincing paper with weak examples. Here are some examples that might work for our sample topic, both weaker and stronger:

Okay Example

paintings, artwork

buildings, churches

flowers, natural
wonders**Better Example**Leonardo da
Vinci's *Mona Lisa*Notre Dame
Cathedral in Paris

Niagara Falls

Good examples are relevant to the topic and contain specific details.

Avoid hypothetical examples—the more specific your example is, the better.

In each case, the better example is the more specific, more detailed example. Also note that we've avoided any personal examples. While you certainly may feel that your boyfriend or girlfriend is the most beautiful person in the world, that sort of personal example won't resonate with an ETS grader nearly as well as a more academic or global example. Use personal examples only when specifically instructed to by the prompt or as a last resort.

Step
2

STEP 2: ORGANIZE

Once you've identified the key terms, considered the opposite side of the issue, and generated some examples, it's time to organize your thoughts. Basically, you'll want to do the following:

1. **Separate Your Examples.** How many of your examples support the pro side and how many support the con side? Divide your examples up and see which side has more support.
2. **Write Your Thesis Statement.** After evaluating the strength of your examples, decide what position you will take in your essay, and then write your thesis. Your thesis is the main point that you want your essay to express.

Let's continue the process on the sample prompt.

Separate Your Examples

Do this before you decide on your thesis statement. Even though you might have a strong preference for one position on the issue, you might notice that the examples you brainstormed tend to support the other side of the issue. Don't expend more time trying to think of examples to support your preconceptions; just write your essay supporting the other side! There is no right or wrong response. All that matters is being able to write a strong, coherent essay in a very limited time. Your personal views or beliefs are unimportant to the ETS graders. If we continue with the examples we used earlier, they would probably break down like this:

Pro

Con

natural
wonders

Mona Lisa
Notre Dame

Based on some of the examples we've come up with, it looks like we'd be better off supporting the idea that "True beauty is found not in the commonplace, but in the exceptional." While natural wonders like sunsets and flowers are pretty commonplace, we've come up with a lot more exceptional examples. And it looks like we could even argue that it is the exceptional natural wonders, such as Niagara Falls, that are truly beautiful.

It doesn't matter what
side of the issue you
take on the GRE.

Write Your Thesis Statement

Now comes the culmination of all of our work. What point do we want to make about the topic?

Our thesis should probably be something along the lines of this: “While certain commonplace natural objects are examples of beauty, true beauty is most often found in rare, exceptional cases.”

Now that we have figured out what we want to say, we can focus on proving why we believe it. But remember: Only after working through these steps are we truly ready to write!

Practice: Steps 1 and 2

Work through steps one and two on the following Issue essay prompts below.

PROMPT 1

“Government funding should never be used to support art that the majority of the population finds distasteful or objectionable.”

Write an essay in which you take a position on the statement above. In developing and supporting your position, you should consider whether the above statement is always true or whether there are exceptions to it.

On your scratch paper, write the (1) Key Terms, (2) Opposite Side, (3) Examples, and (4) Thesis.

PROMPT 2

“Oftentimes, the results of a particular action are not of consequence; rather, it is the way we go about the action that matters most.”

Write an essay in which you take a position on the statement above. In developing and supporting your position, you should consider situations in which the ways matter most as well as situations in which the results matter most.

On your scratch paper, write the (1) Key Terms, (2) Opposite Side, (3) Examples, and (4) Thesis.

Practice: Sample Responses

Obviously, your examples and thesis statements will differ from those given below, but these sample responses will give you a good indication of what ETS is looking for.

Prompt 1

Key Terms: What does *support* mean? Is that just giving money to the artist, or does the government have to commission the work or promote it? What population are we using to judge—the general population, the population of artists, or some other

population? What do we mean when we say art is “objectionable” or “distasteful?” What standards are we using to determine that?

Opposite Side: “Government funding should be used to support art, even if the majority of the population finds the art distasteful.”

Examples: Robert Mapplethorpe controversy; National Endowment for the Arts; Supreme Court rulings on obscenity; Government censorship

Thesis: “While artists have the right to create whatever objectionable art they wish, taxpayers should not have to pay for art they find offensive or obscene.”

Prompt 2

Key Terms: What do we mean by *consequence*? Does this term refer to the results

of the action, or the effects the action has on the person doing the action? Similarly, when we say the way we go about something “matters most,” what criteria are we using?

Opposite Side: “The way we go about a certain action is not of consequence; the results we get are what matter most.”

Examples: Rosa Parks, whose actions helped further the Civil Rights movement; Gandhi, whose methods of nonviolent resistance played a part in Indian independence; Revolutionary War, whose violent methods eventually led to independence for the United States

Thesis: “While people do note the ways in which people go about certain actions, it is usually the ultimate result that matters.”

Step

3

STEP 3: WRITE

Now that we know how to prepare for our Issue essay, we can write it. In this section, we'll discuss various templates for essays and show you how you can pre-construct certain portions of your essay. Before we do that though, let's revisit what the readers are looking for from your writing.

What the Readers Want to See

The essay readers will be looking for four characteristics as they skim your Analysis of an Issue essay (at the speed of light). According to ETS, an outstanding essay

- considers the complexities of the issue

- supports the position with relevant examples
- is clearly well organized
- demonstrates superior facility with the conventions of standard written English, but still with minor flaws

To put it more simply, the readers are looking for good organization, good supporting examples for whatever position you've taken, and reasonably good use of the English language. We've hopefully taken care of the first two parts, so now we'll deal with the next two.

Essay Essentials

As you learned in sixth-grade composition class, a basic essay has three parts: an introduction, some body paragraphs, and a conclusion. These three things are exactly what ETS wants to see in your Analysis of an Issue

essay. Each of these parts has a specific role to play.

1. The **Introduction** should introduce the topic of the essay, discuss the issues surrounding it, and present the essay's thesis.
2. The **Body Paragraphs** should use examples to support the thesis of the essay.
3. The **Conclusion** should summarize the major points of the issue, reiterate the thesis, and perhaps consider its implications.

The basics of an essay
are an introduction,
body paragraphs, and
a conclusion.

Basically, if you try to think of each paragraph as having a specific job to do, you can pretty much preconstruct each type of

paragraph and then fill in the specific details on test day.

Preconstruction: The Introduction

For the Issue essay, a good introduction accomplishes the following tasks:

A good introduction

1. Clearly establishes the topic of the paper
2. Previews both sides of the issue at hand
3. Presents a clear thesis

Let's look at each of these tasks in detail and discuss different ways to accomplish the goals of the introductory paragraph.

Establish the Topic

We want the reader to know what issue the essay is going to talk about. Even though the grader will see the prompt you're writing about, he or she should be able to figure out the prompt just from reading the introduction of your essay. There are a few different ways you can quickly establish the topic, so let's return to our original prompt and pre-construct some approaches.

Don't just restate the prompt! Come up with a strong "hook" for the beginning of your essay.

Here, once again, is our prompt:

“True beauty is found not in the exceptional but in the commonplace.”

Write an essay in which you take a position on the statement above. In developing and supporting your essay, consider instances in which the statement does and does not hold true.

One of the worst ways of establishing the topic is to merely quote the prompt. ETS graders look upon this tactic with disdain, so let's find other ways of starting our essay.

Approach 1: Rhetorical Questions

This approach is a tried-and-true way of introducing your topic. Instead of simply quoting or paraphrasing the prompt, turn it into a rhetorical question. Here are a few samples:

Where does true beauty lie, in the exceptional or in the commonplace?

Do we find the exceptional more beautiful or the commonplace?

Can we find beauty only in rare, exceptional instances or does it truly lie all around us?

It is immediately clear what topic the essay will explore, from each of these examples of introductory sentences. See if you can come

up with a rhetorical question for either this topic or one from the previous drill.

Approach 2: Famous Quotations

Another classic approach to beginning an essay is to use either a well-known saying or a famous quote from someone. Many of the GRE topics are fairly bland, so even if you can't think of a famous quote, there are usually some classic aphorisms you use. Here's what we mean:

“Beauty is Truth, Truth Beauty,” or so said the romantic poet John Keats.

A common saying is that beauty is in the eye of the beholder.

Obviously, this type of introduction can be tough to do if something doesn't pop into your head right away. Try to come up with a quote or common saying for this topic or one from the drill.

Approach 3: Anecdote

An anecdote is a brief story. Oftentimes you can grab your reader's attention and introduce the topic with a good anecdote. Consider this example:

It is said that Cézanne, the famed French painter, was so concerned with the beauty of his paintings that he would destroy any of his works that he felt was flawed.

The Romantic poet John Keats was so struck by the beauty of Chapman's translation of Homer's work that he wrote a poem about it.

A good opening line is great to have, but if you're stuck, don't spend an excessive amount of time trying to come up with something clever.

When using an anecdote you might have to write a sentence or two explaining the relevance of your story. Try out an anecdote for this topic or one of the drill topics.

Approach 4: Fact/Statistic

For some topics, it might be appropriate to start your essay by stating a fact or statistic. ETS graders aren't allowed to penalize you for factual mistakes and they certainly aren't going to fact-check your essay. So don't be afraid if your fact isn't 100 percent accurate. Here's an illustration:

A recent scientific study showed that the faces that people find the most beautiful are those that are the most symmetrical.

Psychologists have demonstrated that people's responses to certain phenomena are based on certain innate mechanisms in the brain.

Give this approach a shot, using this topic or one from the drill.

Approach 5: Definition

One way you may wish to start your essay is by defining one of the key terms from the prompt:

Beauty, by definition, is that which moves us or impacts us significantly.

The “exceptional” typically refers to those things that stand out, which is also a plausible definition for beauty.

The advantage to this approach is that you already spent some time thinking along these lines when you were planning your essay. Come up with a sample introductory sentence for this topic or one of the drill topics.

Preview the Issue

Once you've told the reader what the topic is, your next task is to inform the reader of the issues at hand. You want to briefly touch on both sides of the debate, explaining the pros and cons of the prompt. A good way to accomplish this is to make use of strong trigger words—words like *but*, *despite*, *while*, and *although*. Here are some examples.

While some people can find beauty in the most common of places, true beauty is found only in the exceptional.

Some would argue that beauty is found everywhere, from the flowers to the stars, but others would state that true beauty is found only in rare, special instances.

Despite the assertions of many that beauty is everywhere, true beauty is found only in exceptional cases.

Although one might argue that many commonplace things are beautiful, it is the exceptional things that possess true beauty.

There can be no doubt that some of the world's most common things are beautiful. And yet, it is

often the exceptional objects that possess true beauty.

Practice writing sentences that address both sides of the issue. Use the sample topic or one from the drill.

Present the Thesis

Your final task in the introduction is to present the thesis. Some writers prefer to avoid the first person, refusing to use sentences such as “I believe ...” or “I feel ...” However, GRE graders will not penalize you for use of the first person. A more important consideration when writing your thesis is giving the reader some indication why you hold your particular position. ETS graders want to see that you’ve thought about and analyzed the issue. Here are some examples of thesis statements.

118/150,
A good thesis tells the reader exactly what your position is and why.

I believe that beauty is truly found in the exceptional, not in the commonplace, because if common things were beautiful, the very word would lose its meaning.

In my view, beauty is found in the exceptional, not in the commonplace, because only exceptional things really stand out as special in our minds.

It is clear that true beauty is not to be found in the commonplace but in the exceptional. On closer inspection, even so-called common objects that people consider beautiful are actually exceptional.

After weighing the evidence, it is certain that beauty is the province of the exceptional, not the commonplace. People find true beauty in things that they rarely experience, not the things they experience every day.

For each thesis, you can see that the author is also giving some justification for the viewpoint. This justification will be of course explored more thoroughly in the body paragraphs, but it's good to give the reader a preview of how your essay will take shape. Try writing thesis statements for some of the sample prompts.

Preconstruction: Body Paragraphs

A body paragraph should do the following:

Good body paragraphs

1. Use a good transition/topic sentence
2. Present an example
3. Explain how the example supports the thesis

Body paragraphs are a little harder to pre-construct because they are the most specific part of the essay. Still, there are some handy tips for creating body paragraphs that an ETS grader will love.

Transition/Topic Sentence

ETS graders love organized essays that flow well. The best way to write an essay like this is to use strong topic sentences and good

transitions for each of your body paragraphs. Your topic sentence should serve as a gentle reminder to the reader of what the thesis of the essay is. Here's an example:

One example of beauty found in the exceptional is Leonardo da Vinci's Mona Lisa.

A second instance in which true beauty lies not in the commonplace but in the exceptional is Notre Dame Cathedral in Paris.

Of course, you might want to avoid using simple transitions like "the first example," and "the second example." You can make your writing stronger by leading with the example and making the transition a little more subtle, like so:

Leonardo da Vinci's Mona Lisa is surely one of the most exceptional, and beautiful, paintings ever created.

Consider the beauty of Notre Dame Cathedral in Paris, a building that is in no way commonplace.

Or to get even fancier, refer to the previous example in your transition sentence:

Like da Vinci's Mona Lisa, the cathedral of Notre Dame in Paris is an exceptional, and exceptionally beautiful, object.

The important point is that each sentence introduces the example and reminds the reader of the purpose of the example, which in this case is to support the notion of beauty as exceptional. In the next few sentences, you'll provide details about your example. It's

important that you remember to link the example to your thesis.

Explain How Your Example Supports Your Thesis

On the GRE essays, don't get so caught up in providing details for your example that you forget to explain to the reader how or why your example helps your thesis. The purpose of the Issue essay is not to just list some examples; the purpose is to develop and support a position on the issue. Here's an example of a body paragraph that doesn't quite fulfill that goal:

Like da Vinci's Mona Lisa, the cathedral of Notre Dame in Paris is an exceptional, and exceptionally beautiful, object. Notre Dame is a stunning example of gothic architecture, famous for the flying buttresses that adorn the sides of

the building. The cathedral also has rows and rows of beautiful sculptures recessed into the walls, as well as a gorgeous central stained-glass window. These features make Notre Dame one of the most beautiful cathedrals in the world.

Don't just tell the grader about the example; tell the grader why the example is relevant to your thesis.

The writer here did a good job of providing specific details about the example, which ETS graders love. However, the reader failed to explain why Notre Dame supports the view that true beauty is exceptional, not commonplace. Let's fix that:

Like da Vinci's Mona Lisa, the cathedral of Notre Dame in Paris is an exceptional, and exceptionally beautiful, object. Churches and cathedrals line the streets of most major cities in

Western Europe, but few possess the renown of Notre Dame. Notre Dame is a stunning example of gothic architecture, famous for the flying buttresses that adorn the sides of the building. The cathedral also has rows and rows of beautiful sculptures recessed into the walls, as well as a gorgeous central stained-glass window. These features make Notre Dame one of the most beautiful cathedrals in the world. Compared to a common church or cathedral, Notre Dame is truly awe-inspiring; Victor Hugo used the building as the backdrop for his magnificent book The Hunchback of Notre Dame and thousands of tourists travel untold miles to view the cathedral. That sort of beauty is not possessed by just any church on the corner.

This is a stronger body paragraph because it is more explicit in its discussion of the thesis. The author notes that churches and cathedrals are fairly common, but then argues that Notre Dame stands out as an exceptional

cathedral. The author concludes the paragraph by showing how Notre Dame is more beautiful than any typical church. Just as a reader should be able to figure out what the topic of the paper is from the introduction, a reader should be able to figure out the thesis from each paragraph.

Write a body paragraph for one of the examples for this sample topic, or one of your examples from the practice. Make sure you have a good topic/transition sentence, specific details for the example, and an explanation of how or why the example is relevant to the thesis.

Preconstruction: Conclusion Paragraphs

Your essay should always have a conclusion, for two reasons. First, a conclusion paragraph is evidence of good organization. It

shows the reader that you knew exactly what points you wanted to make, you made them, and now you're ending the essay. And second, an essay that lacks a conclusion seems incomplete, almost as if your writing abruptly ends before it should. This can give the grader a negative impression of your essay. Fortunately, conclusion paragraphs are easy to write.

Make sure your essay
has a conclusion.

A good conclusion

1. Alerts the reader that the essay is ending
2. Summarizes the main points of the essay

Some test takers even prefer to write their introduction and conclusion first and then fill in the body paragraphs. This strategy has the advantage of making your essay seem complete even if you happen to run out of time writing the body paragraphs.

Alert the Reader

Conclusion paragraphs have their own topic/transition sentences, which generally should contain a word or phrase that tells the reader he or she is reaching the end. Here are some examples:

In conclusion, it's clear that true beauty is found not in the commonplace, but in the exceptional.

Ultimately, beauty lies in the exceptional, not in the commonplace.

As the bulk of the evidence shows, the exceptional, not the commonplace, possesses true beauty.

Clearly, true beauty is found in exceptional things, not in commonplace ones.

The examples above all support the idea that we find true beauty in exceptional cases, not in commonplace ones.

Write some conclusion sentences for this topic or a sample topic from the sample prompts.

Summarize Main Points

Your conclusion should also summarize the main points of the essay, meaning that it should mention the thesis and how the examples support it. Additionally, you can

briefly consider the implications of the thesis. Here are some sample conclusions:

In conclusion, it's clear that true beauty is found not in the commonplace, but in the exceptional. The Mona Lisa and Notre Dame Cathedral are both exceptional examples of fairly commonplace things and it is these exceptions that are noted as truly beautiful. If anything, the commonplace serves only as a contrast to what true beauty really is.

Ultimately, beauty lies in the exceptional, not the commonplace. While paintings and churches are fairly commonplace, only a small few of them, such as the Mona Lisa or Notre Dame, truly reach the heights of beauty. It is in these exceptions that we find real beauty.

The examples above all support the idea that we find true beauty in exceptional cases, not in commonplace ones. Common things may seem at first glance to be beautiful, but once we compare these commonplace examples to the truly exceptional ones, we see that the exceptional ones are truly beautiful.

Try your hand at constructing a conclusion paragraph, once again using this topic or one from the sample prompts.

Putting It All Together

Read through this sample essay that's based on the basic five-paragraph model. Then you'll have the chance to try writing a similar essay for a different prompt.

“True beauty is found not in the exceptional but in the commonplace.”

Write an essay in which you take a position on the statement above. In developing and supporting your essay, consider instances in which the statement does and does not hold true.

Beauty, by definition, is that which moves us or impacts us significantly. Some would argue that beauty is found everywhere, from the flowers to the stars. But others would state that true beauty is found only in rare, special instances. After weighing the evidence, it is certain that beauty is the province of the exceptional, not the commonplace. People are moved most by things that they

rarely experience, not the things they experience every day.

Those who would argue that true beauty is everywhere might point to the beauty of a flower, or the starlit night. These experiences are certainly common, but do they show that true beauty is commonplace? Flowers might be considered beautiful, but how often does a person stop to look at or appreciate every flower? Flowers are so common that in many cases, they are ignored or viewed as nothing special. However, on those rare occasions—exceptional occasions, one might say—when we want to commemorate an event or express emotion, we notice the beauty of flowers. Thus, it is not the commonplace flower that strikes us as beautiful, but the exceptional situations themselves that move us to appreciate the flower.

Now consider the exceptional. Leonardo da Vinci's Mona Lisa is surely one of the most exceptional, and beautiful, paintings ever created. Few people who view the painting are not moved by the sheer beauty of it, and the Mona Lisa is instantly recognized as a masterpiece of art. And yet, there have been literally millions of paintings produced in human history. Is every single one of them beautiful? Does every one of those paintings have the impact that da Vinci's does? Of course not. In order to find beauty, we must separate the exceptional cases from the common ones. True beauty is such because it stands out from the masses of the average and pedestrian.

Like da Vinci's Mona Lisa, the cathedral of Notre Dame in Paris is an exceptional, and exceptionally beautiful, object. Churches and cathedrals line the streets of most major cities in Western Europe, but few possess the renown of Notre Dame, one of the most beautiful cathedrals in the world. Compared to a common church or

cathedral, Notre Dame is truly awe-inspiring; Victor Hugo used the building as the backdrop for his magnificent book The Hunchback of Notre Dame and thousands of tourists travel untold miles to view the cathedral. That sort of beauty is not possessed by just any church on the corner.

In conclusion, it's clear that true beauty is found not in the commonplace, but in the exceptional. The Mona Lisa and Notre Dame Cathedral are both exceptional examples of fairly commonplace things and it is these exceptions that are noted as truly beautiful. If anything, the commonplace serves only as a contrast so that we can understand what true beauty really is.

Your Turn

Try writing a similar essay for the prompt that follows this paragraph. Make sure you

consider the opposing side of the argument. Devote a paragraph to looking at an example for the other side of the issue, but make sure you indicate to the reader that there is a flaw in the example or that the example is less than convincing. Set a timer for 30 minutes to practice GRE time constraints.

“People most respect the powerful not when they exercise their power, but when they refrain from exercising it.”

Write an essay in which you develop and support a position on the statement above. In writing your essay, you should consider both when the statement may be true and when it may be false.

How to Score Your Essay

Now it's time to put on your essay-scoring hat and prepare to grade your own essay. If you're lucky enough to have a friend who is also preparing for the GRE, you could switch essays and grade each other's like you used to do in sixth grade. You'll need to be objective during this process. Remember: The only way to improve is to honestly assess your weaknesses and systematically eliminate them.

Set a timer for 2 minutes. Read the essay carefully but quickly, so that you do not exceed the 2 minutes on the timer.

Now ask yourself the following questions about the essay:

1. Overall, did it make sense?
2. Did you address the topic directly?

3. Did you address the topic thoroughly?
4. Did your introduction paragraph repeat the issue to establish the topic of the essay?
5. Did you consider both sides of the issue?
6. Did your examples make sense?
7. Did you flesh out your examples with details?
8. Did you explain how your examples supported your thesis?
9. Did your essay have a strong concluding paragraph?
10. Was your essay well organized, using transitions and topic sentences?
11. Did you use language that made the organization of the essay obvious?
12. Did you use correct grammar, spelling, and language, for the most part?

If you could answer “yes” to all or almost all of these questions, congratulations! Your essay would probably receive a score in the 5–6 range. If you continue to practice, and write an essay of similar quality on the real Analysis of an Issue section of the real test, you should score very well.

If you answered “yes” to fewer than 12 of the questions, you have room for improvement. Fortunately, you also know which areas you need to strengthen as you continue to practice.

If you answered “yes” to fewer than 6 of the questions, your essay would probably not score very well on a real GRE. An essay of this quality would not help you in the admissions process and could raise some red flags in the minds of the admissions people. You need to continue to practice, focusing on the

areas of weakness that you discovered during this scoring process.

Another Sample Response

Take a look at a high scoring response to the prompt you just practiced on. Your essay might look different and that's fine. This is just one of many ways to successfully complete the Issue essay assignment.

“The powerful are most respected not when they exercise their power, but when they refrain from exercising it.”

Write an essay in which you develop and support a position on the statement above. In writing your essay, you should

consider both when the statement may be true and when it may be false.

What aspect of power engenders the greatest respect? Some would argue that power inspires respect only by its ability to change things or bring about results. This camp respects the powerful only when they demonstrate their power by raising a massive army or bestowing charity on the less fortunate. Others believe that the true measure of power lies not in what it is used for, but in how it is restrained. These people believe that people most respect the powerful when they choose not to use their power, such as granting clemency to a criminal on death row or allowing critics of the government to speak out.

Consider first the respect people hold for the exercise of power. One of the mightiest displays of power is the ability to protect and safeguard people and property and this aspect of government is what many people respect. Indeed, in Hobbes's Leviathan, he argued that one of the reasons people sacrifice themselves for the good of the state is to preserve the power of the state to protect its members from outside attacks. And one of the stated goals of the United States massive military buildup was so that other countries would either "love us or fear us." Thus, it is clear that people have respect for displays of power. Similarly, the ability of the powerful to bestow gifts of charity on the less fortunate is also well respected. The names of philanthropists like Carnegie and Rockefeller are held in high esteem because they used their power to help those less fortunate than themselves.

On the other hand, the ability to show restraint can also engender respect. Recently, the

governor of Illinois decided to commute the death sentences of all the prisoners on death row. Such an act of clemency brought high praise from human rights proponents around the world. Furthermore, the fact that democratic governments allow dissent when they could in many cases censor or squash unfavorable opinions also lends credence to the view that restraint of power is what people respect. For example, the arbitrary arrest and sentencing of political dissidents in Russia has brought much international criticism of the Kremlin, while countries that support freedom of speech and the press are widely respected in the world.

Ultimately, after considering both sides of the issue, it must be concluded that the exercise of power is most respected. This is because even in cases of restraint, the entity in power is still exercising its power. Granting clemency is possible only because the state holds the power of life and death. Allowing dissent is exceptional only

because the government has the power to crush it. Thus, it is not the restraint of power that people most respect, it is the exercise of it.

FINAL THOUGHTS: WHAT TO DO WITH YOUR TIME

Now that you know how to construct your essay, you have to practice writing essays in a mere 30 minutes. Here's a guideline for how to use your time:

- Find key terms, state the opposite side, brainstorm examples: 5–7 minutes
- Formulate a thesis: 2 minutes
- Write the essay: 18–20 minutes
- Proofread: 1–2 minutes



Your essay doesn't have to be perfect. Focus on the

big picture.

Notice that not a lot of time is allotted for proofreading. Remember that it's okay to have minor spelling and grammatical errors. Your time is better spent making sure you consider both sides of the issue completely and write an effective essay. For tons more practice, you can go to www.ets.org/gre for the complete list of essay topics.

Summary

- Follow the three simple steps to essay success: Think, Organize, Write.
- One of the keys to high scoring essays is good examples. Make sure your examples are relevant to the topic and as specific as possible.
- Try to use examples drawn from your readings, current events, literature, and history. Avoid personal examples.
- Spice up your writing by employing an interesting “hook” to get your readers’ attention. Consider using such hooks as rhetorical questions, quotes, anecdotes, facts and

statistics, and other attention-getting devices.

- A good GRE essay presents a smooth flow of ideas and examples. Make sure you use transitions to help your reader follow the progression of ideas in your essay.
- Templates can be effective ways of organizing your essay, but don't feel restricted to them. Come up with your own template or modify the existing templates as you see fit.

Chapter 16

The Argument Essay

The Argument essay of the GRE asks you to examine and critique the logic of an argument. The arguments you will see in this chapter are similar to the ones you worked with earlier in the book and you will need to use the same approach to breaking these arguments down. This chapter will show you how to organize and write an essay once you've found the premises, conclusion, and assumptions of a GRE argument.

You'll be able to use all the skills we've discussed for the Analysis of an Issue essays on this type of essay as well, but in a slightly different way. Instead of asking for your opinion on a topic, the Analysis of an Argument essay asks you to critique someone else's argument. Before we jump into setting up templates and other preconstruction steps, let's take a look at how Analytical Writing arguments work.

THE PARTS OF AN ARGUMENT

As seen in the Critical Reasoning portion in [Chapter 6](#), an argument, for GRE purposes, is a short paragraph in which an author introduces a topic and uses reasoning or factual evidence to back up his or her opinion about that topic.

The following statement is a really simplified example of an argument:

My car broke down yesterday, and I need a car to get to work. Therefore, I should buy a new car.



The car argument above is composed of three parts:

- The conclusion—the author’s opinion and recommendation for action
- The premises—the facts the author uses to back up his or her opinion
- The assumptions—unstated conditions that must be true in order for the argument to make sense

In this argument, the author’s conclusion is “I should buy a new car.”

The premises the author uses to support this conclusion are that his car broke down yesterday, and that he needs a car to get to work.

The premises must support the conclusion the way table legs support a tabletop. The tabletop is the most obvious and useful part of a table—you see more of it, and you can

put things on it. But without the legs to hold it up, it's just a slab of wood on the floor. The same is true for the conclusion of an argument. The conclusion is the part that gets all the attention, since it recommends some course of action, but without the premises to support the conclusion, the conclusion won't hold up.

Conclusion Words

Certain words indicate a conclusion:

- so
- therefore
- thus
- hence
- showed that
- clearly
- then
- consequently
- as a result

- concluded that

When you see these words, you can be relatively sure that you've found the conclusion of the argument.

Premise Words

Certain words indicate premises:

- because
- since
- if
- given that
- in view of
- in light of
- assume

ASSUMPTIONS

An assumption is an unstated premise that supports the author's conclusion. It's the connection between the stated premises and the conclusion. In the example of the table, the assumption is that nails or glue hold the legs and the tabletop together. Without the glue or nails, the table will fall apart. Without the assumption, the argument will fall apart.

Sometimes the assumption is described as the *gap* between the facts that make up the premises and the conclusion. They don't always connect, so the assumption is the gap between them.

Let's take a look back at the car argument:

My car broke down yesterday, and I need a car to get to work. Therefore, I should buy a new car.

The premises are that my car broke down yesterday and I need a car to get to work. The conclusion is that I should buy a new car.

When you first read this argument, you may have had some questions. These questions might have been along the lines of “Why can’t the author just rent a car?” or “Why can’t the author just fix the car?”

As you read an argument, identifying the premises and conclusion, questions may pop into your head. Those questions are pointing out the gap that leads to the assumption. Here, the gap is between having a broken car and still needing a car to get to work on the

one side, and having to buy a new car on the other side.

Therefore, the assumption must be as follows:

There is no other way to have a car.

There are all sorts of smaller assumptions here—that the car can't be fixed, that a car can't be rented, that there's no other car the author can borrow—but those are all covered in the main assumption.

The assumption fills the gap between the premises and the conclusion, and, in fact, functions as an unstated premise:

My car broke down yesterday, and I need a car to get to work. There is no other way to have a car. Therefore, I should buy a new car.

Brainstorming for the Argument Essay consists primarily of coming up with a list of assumptions.

Three Common Types of Arguments and Their Assumptions

There are three types of arguments you are likely to see. They are Sampling, Analogy, and Causal. Becoming familiar with these three types will help you identify the assumptions in the argument more quickly when the clock is ticking on the real test.

Step
1

1. The Sampling Assumption

A sampling argument assumes that a small group is representative of a much larger group to which it belongs. To attack a sampling argument, show that one cannot assume that the opinions or experiences of the smaller group are not necessarily representative of the larger group.

Step 2

2. The Analogy Assumption

An argument by analogy assumes that $A = B$ or that what is true for one entity will be true for another. To attack an argument by analogy, simply show that the two groups or places or individuals are nothing like each

other. What is true for one does not have to be true of the other.

Step 3

3. The Causal Assumption

A causal argument assumes that A causes B, or that if you remove the cause, you will remove the effect. While there may be a strong correlation between A and B, it does not always follow that it is a causal relationship or that A is the cause of B. To attack a causal relationship, point out that there are other possible causes for B and brainstorm some possible examples.

Well, Great, But Why Do I Care?

You should care about taking apart the argument, and finding the assumptions in particular, because the key to writing a great Argument essay on the Analytical Writing section is ripping apart the argument.

Think about it. The official instructions on the test ask you to “critique” the author’s argument. However, if you claim that everything the author says makes sense, you won’t be able to write an essay that’s more than a few sentences long. This means that in order to write a great essay, you’ll need to tear the author’s argument apart.

Danger: The most common mistake people make in writing the Argument essay is expressing their own opinions.

Don't do this! The Issue essay specifically asks you to give an opinion and then back it up. The Argument essay wants a critique of someone else's opinion, not your own.

WRITING THE ARGUMENT ESSAY

Writing the Analysis of an Argument essay requires a series of steps.

Step 1:

Read the topic and identify the conclusion and the premises.

Step 2:

Since they're asking you to critique (i.e., weaken) the argument, concentrate on identifying its assumptions. Look for gaps in the argument, weaknesses in the logic, and new information in the conclusion that wasn't present in the premises. Brainstorm as many different assumptions as you can think of. Write these out on your scratch paper or on the computer screen.

You will have 30 minutes to plan and compose a response to the argument topic, so make sure to budget your time wisely.

Step 3:

Select three or four of the strongest assumptions around which to build your essay.

Step 4:

Choose a template that allows you to attack the assumptions in an organized way.

Step 5:

Write the essay, using all the tools and techniques that you'll be learning in this chapter.

Step 6:

Read over the essay and edit it.

WHAT THE READERS ARE LOOKING FOR

In the Analysis of an Argument topic section, your job is to critique the argument's line of reasoning and the evidence supporting it and to suggest ways in which the argument could be strengthened. Again, you aren't required to know any more about the subject than would any normal person—but you must be able to spot logical weaknesses. Make absolutely sure you have read and understood the previous section about taking apart the argument.

The essay readers will be looking for four things as they skim through your Analysis of an Argument essay at the speed of light. According to a booklet prepared by ETS, “An outstanding argument essay ... clearly identifies and insightfully analyzes important

features of the argument; develops ideas coherently, organizes them logically, and connects them smoothly with clear transitions; effectively supports the main points of the critique; and demonstrates superior control of language, including diction, syntactic variety, and the conventions of standard written English. There may be minor flaws.”

Your opinion is not the point in an Analysis of an Argument Essay.

To put it more simply, the readers will be looking for all the same things they were looking for in the Analysis of an Issue essay, plus one extra ingredient: a cursory knowledge of the rules of logic.

Doing the Actual Analysis of the Argument

In any Analytical Writing argument, the first thing you should do is separate the conclusion from the premises.

Let's see how this works with an actual essay topic.

Topic:

The director of the International Health Foundation recently released this announcement:

“A new medical test that allows the early detection of a particular disease will prevent the deaths of people all over the world who would otherwise die from the disease. The test has been extremely effective in allowing doctors to

diagnose the disease six months to a year before it would have been spotted by conventional means. As soon as we can institute this test as routine procedure in hospitals around the world, the death rate from this disease will plummet.”

Save the fancy prose for English class! Your grader cares more that you can identify the parts of the argument than for a clever turn of phrase.

The conclusion in this argument comes in the first line:

A new medical test that allows the early detection of a particular disease will prevent the deaths of people all over the world who

would otherwise die from that disease.

The premises are the evidence in support of this conclusion.

The test has been extremely effective in allowing doctors to diagnose the disease six months to a year before it would have been spotted by conventional means.

The assumptions are the unspoken premises of the argument—without which the argument would fall apart. Remember that assumptions are often causal, analogical, or statistical. What are some assumptions of this argument? Let's brainstorm.

Brainstorming for Assumptions

You can often find assumptions by looking for a gap in the reasoning. “Medical tests allow early detection”: According to the conclusion, this medical test leads to the early detection of the disease. There doesn’t seem to be a gap here.

“Early detection allows patients to survive”: In turn, the early detection of the disease allows patients to survive the disease. Well, hold on a minute. Is this necessarily true?

- First, do we know that early detection will *necessarily* lead to survival? We don’t even know if this disease is curable. Early detection of an incurable disease is not going to help anyone survive it.
- Second, will the test be widely available and cheap enough for general

use? If the test is expensive or available only in certain parts of the world, people will continue to die from the disease.

- Third, will doctors and patients interpret the tests correctly? The test may be fine, but if doctors misinterpret the results or if patients ignore the need for treatment, then the test will not save lives.

“Death rate will plummet”: There’s a huge gap here in that there’s absolutely no explanation of how merely detecting the disease will immediately cause the death rate from it to plummet. This area is ripe for exploration.

Organizing the Analysis of an Argument Essay

We’re now ready to put this into a ready-made template. In any Analysis of an

Argument essay, the template structure should be pretty straightforward: You're simply going to reiterate the argument, attack the argument in three different ways (each in a separate paragraph), summarize what you've said, and mention how the argument could be strengthened. From an organizational standpoint, this is pretty easy. Try to minimize your use of the word *I*. Your opinion is not the point in an Analysis of an Argument essay.

The arguments provided for the writing assessment of the GRE typically contain more flaws than those you worked with in the multiple-choice section. The flaws are often easier to spot as well.

A Sample Template

Of course, you will want to develop your own template for the Analysis of an Argument essay, but to get you started, here's one possible structure:

The argument that (restatement of the conclusion) is not entirely logically convincing, since it ignores certain crucial assumptions.

First, the argument assumes that

Second, the argument never addresses

Finally, the argument omits

Thus, the argument is not completely sound. The evidence in support of the conclusion

Ultimately, the argument might have been strengthened by

The key to succeeding on an Analysis of an Argument essay is to critique the argument clearly.

How Would the Result of Our Brainstorming Fit into the Template?

Here's how the assumptions we came up with for this argument would fit into the template:

The argument that the new medical test will prevent deaths that would have occurred in the past is not entirely logically convincing since it ignores certain crucial assumptions.

First, the argument assumes that early detection of the disease will lead to an immediate drop in the mortality rate from this disease, yet it does nothing to explain how this will happen, and so on.

Second, the argument never addresses the point that the existence of this new test, even if totally effective, is not the same as the widespread use of the test, and so on.

Finally, even supposing the ability of early detection to save lives and the widespread use of the test, the argument still depends on the doctors' correct interpretation of the test and the patients' willingness to undergo treatment, and so on.

Thus, the argument is not completely sound. The evidence in support of the conclusion that the test will cause death rates to plummet does little to prove that conclusion, since it does not address the assumptions already raised. Ultimately, the argument might have

been strengthened if the author could have shown that the disease responds to early treatment, which can be enacted immediately upon receipt of the test results, that the test will be widely available around the world, and that doctors and patients will make proper use of the test.

Customizing Your Analysis of an Argument Template

Your organizational structure may vary in some ways, but it will always include the following elements: The first paragraph should sum up the argument's conclusion. The second, third, and fourth paragraphs will attack the argument and the supporting evidence. The last paragraph should summarize what you've said and state how the argument

could be strengthened. Here are some alternate ways of organizing your essay:

Variation 1

1st paragraph: Restate the argument.

2nd paragraph: Discuss the link (or lack thereof) between the conclusion and the evidence presented in support of it.

3rd paragraph: Show three holes in the reasoning of the argument.

4th paragraph: Show how each of the three holes could be plugged up by explicitly stating the missing assumptions.

5th paragraph: Summarize and conclude that because of these three holes, the argument is weak.

Variation 2

1st paragraph: Restate the argument and say it has three flaws.

2nd paragraph: Point out a flaw and show how it could be plugged up by explicitly stating the missing assumption.

3rd paragraph: Point out a second flaw and show how it could be plugged up by explicitly stating the missing assumption.

4th paragraph: Point out a third flaw and show how it could be plugged up by

explicitly stating the missing assumption.

5th paragraph: Summarize and conclude that because of these three flaws, the argument is weak.

You Are Ready to Write an Argument Essay

You've separated the conclusion from the premises. You've brainstormed for the gaps that weaken the argument. You've noted how the premises support (or don't support) the conclusion. Now it's time to write your essay. Start typing, indenting each of the four or five paragraphs. Use all the tools you've learned in this chapter. Remember to keep an eye on the time. Again, if you have a minute at the end, read over your essay and do any editing that's necessary.

What To Do with Your Time

Now that you know how to construct your essay, you have to practice writing essays in a mere 30 minutes. Here's a guideline for how to use your time:

- Break down the argument: 3–4 minutes
- Find 2–3 assumptions: 3–4 minutes
- Write the essay: 18–20 minutes
- Proofread: 1–2 minutes

Notice that not a lot of time is allotted for proofreading. Remember that it's okay to have minor spelling and grammatical errors. Your time is better spent making sure you

consider both sides of the issue completely and write an effective essay.

Practice: Writing an Argument Essay

Practice on the following sample argument topic. If you have access to a computer, turn it on and start up a word-processing program (again, you may want to use a very rudimentary one like Notepad to simulate the ETS program you'll see on the real test). Then set a timer for 30 minutes. In that time, read the topic, brainstorm in the space provided in this book, and then type your essay into the computer.

When writing your essay, make sure to use terms like *causal*, *analogy*, *sampling*, and so forth. Nothing impresses an ETS grader more than a

1183/1807
sentence like “The argument assumes the sample is representative.”

A Sample Argument

The market for the luxury-goods industry is on the decline. Recent reports show that a higher unemployment rate, coupled with consumer fears, has decreased the amount of money the average household spends on both essential and nonessential items, but especially on nonessential items. Since luxury goods are, by nature, nonessential, this market will be the first to decrease in the present economic climate, and luxury retailers should refocus their attention to lower-priced markets.

Conclusion:

Why? (premises)

Assumptions:

Ways you can pull the argument apart:

Ways the argument could be made more compelling:

Now use the template you developed earlier in this chapter to type your essay on a computer.

How to Score Your Essay

It's time to put on your essay-scoring hat and prepare to grade your own essay. (Again, if

you're lucky enough to have a friend who is also preparing for the GRE, you could switch essays.) You'll need to be objective about the process. The only way to improve is to honestly assess your weaknesses and systematically eliminate them.

Set a timer for 2 minutes. Read the essay carefully but quickly, so that you do not exceed the 2 minutes on the timer.

Now ask yourself the following questions about the essay:

1. Overall, did it make sense?
2. Did you address the argument directly?
3. Did you critique the argument thoroughly?
4. Did your introduction paragraph repeat the argument to establish the topic of the essay?

5. Did you avoid injecting your own opinion into the essay?
6. Did your essay have three strong paragraphs critiquing the arguments?
7. Did your critiques make sense?
8. Did you flesh out your points to make the weaknesses of the argument explicit?
9. Did the examples apply directly to the topic?
10. Did the essay have a strong conclusion paragraph?
11. Was the essay well organized?
12. Did you use language that made the organization of the essay obvious?
13. Did you use correct grammar, spelling, and language, for the most part?
14. Was the essay of an appropriate length (four to five paragraphs of at least three sentences each)?

If you could answer “yes” to all or almost all of those questions, congratulations! Your essay would probably receive a score in the 5–6 range. If you continue to practice, and write an essay of similar quality on the Analysis of an Argument essay on the real test, you should score very well.

If you answered “yes” to fewer than 12 of the questions, you have room for improvement. Fortunately, you also know which areas you need to strengthen as you continue to practice.

If you answered “yes” to fewer than 5 of the questions, your essay would probably not score very well on a real GRE. You need to continue to practice, focusing on the areas of weakness that you discovered during this scoring process.

There are more Argument topics for you to practice in the back of this book, but if you'd like to practice even more, go to www.gre.org and view the list of real Argument topics. You cannot possibly practice writing essays on all of these real ETS topics, so don't even try. However, you should spend time reading through them to become familiar with the variety of topics that ETS may give you.

Just Keep Practicing

So now you've read everything you need to know about writing high-scoring essays on the GRE. With a little practice, writing these essays should become second nature, and you'll find yourself sitting at the word processor on test day confident and prepared. Keep it up!

Summary

- Always start by identifying the conclusion of the argument.
- Look for the common types of arguments: Sampling, Analogy, and Causal.
- Brainstorm all of the assumptions that attach the premises to the conclusion.
- Outline your essay on your scratch paper before you start writing.
- Leave yourself 2 minutes to proofread your essay once you are done writing.

Part V
Answers and
Explanations to
Drills and Practice
Sets

CHAPTER 4: TEXT COMPLETIONS

Practice: Finding the Clue

1. Your words: *bad, tortured, negative*; Underline: *reflected in the harrowing nature*
2. Your words: *highest, lofty, tallest*; Underline: *second highest mountain in the world, reaching more than 28,000 feet high*
3. Your words: *dangerous, deadly, deleterious*; Underline: *wind-chill warning, minus 25 degrees Fahrenheit or lower*

4. Your words: *leftovers, remnants, remains*; Underline: *70-year-old, from World War II*
5. Your words: *distinct, different, dissimilar*; Underline: *mammoths were hairy with long tusks, while mastodons had low-slung bodies and flatter skulls*
6. Your words: *practical, pragmatic, apolitical*; Underline: *he crafted his policies not with an eye toward their political consequences but instead toward their practical effects*
7. Your words: *amount, volume, preponderance*; Underline: *he imagined that he'd have to read for hours and hours each day to finish it all*

8. Your words: *derived, obtained, borrowed*; Underline: *from the Arabic word "Algol"*

Practice: Clues and Triggers

1. Your words: *poor, disastrous, bad*; Underline: *top talents, ended his career*; Circle: *but*
2. Your words: *praise, accolades, thanks*; Underline: *she brokered a diplomatic solution to a potential crisis*; Circle: *work; she*
3. Your words: *healthful, beneficial, good*; Underline: *detrimental to one's health*; Circle: *While*

4. Your words: *disconnected, separate, apart*; Underline: *technological connectivity*; Circle: *Despite*
5. Your words: *graceful, beautiful, positive*; Underline: *ugliness and clumsiness*; Circle: *Although*
6. Your words: *gauge, sign, portent*; Underline: *use holiday sales to gauge future stock prices*; Circle: *prices; thus*
7. Your words: *negativity, animosity, antagonism*; Underline: *ironic, negative view*; Circle: *while, rarely*
8. Your words: *toxicity, danger, hazards*; Underline: *devastating effects on insects*; Circle: *insects; however*

Text Completions Drill

1. **B sorrow**

The trigger *despite* tells you to change direction from the clue *smile*. Therefore, the blank must be something sad. Only *sorrow* fits. *Jubilance* and *liveliness* are the opposite of what would fit the blank. *Vision* is not a change of direction from *smile*. *Mischievousness* means naughtiness, which is not the opposite of *smile*.

2. **D acute**

The trigger *while* tells you to change direction from the clue *blunt*. Thus, black bears must have *sharp* claws. Only *acute* means sharp. *Obtuse* is nearly the opposite of sharp.

1106/1507

Abominable, barren, and fearful do not mean sharp.

3. C static

The semicolon in this sentence acts as a same-direction trigger, which indicates that what follows should continue the idea of “stability versus change.” To keep the flow, you will need replacement words for the opposing pair in the first clause. You already have *different* to stand in for *change*; you’ll need a word that describes *stability* to go in the blank. Try *stable* and use POE. An even shorter way to crack this is to use the trigger word *yet*, which tells you that the word in the blank contrasts with *different*. In either case, *static* is the only choice that makes sense.

4. E prodigious

The clue in this sentence is “property values and industrial output ... rose exponentially,” which tells you the ripples were large. *Persistent* does not address the rise in values and output, while neither *invaluable* nor *incredulous* makes sense in the blank’s context. *Severe*, in contrast, implies a negative economic outcome, something unlikely if values and output were increasing. *Prodigious*, which means impressively great, is the word closest to *large*.

5. B **stolidity**

The clue in the sentence is *inured*, which means toughened to the point where one does not respond. If the voters are inured, then they would not have a strong reaction, so a good word for the blank might be *stoicism* or *ambivalence*. *Stolidity* is the best answer.

Eliminate *amazement*, *exasperation*, and *alarm* because they don't fit. They are not confused by the tax, so eliminate *perplexity*.

6. B commensurate

Find the clue. The clue is “desirable to expand the yield of a harvest” when “additions in time, exertion, and other variable factors of production are not also required.” A word such as *similar* or *related* in the blank will convey the idea that increasing yield should not require increased work. Eliminate choices (A), (D), and (E). Choice (C), *analogous*, is close, but the sentence is not trying to create an analogy. *Commensurate* is the best choice.

Text Completions Practice Set

1. **B futile**

The clue is “global interconnectedness on the rise.” In such a situation, the United States might allow its own interests to be harmed if it tried to stay neutral during wartime. Thus, you need a word that means *doomed* for the blank. Something *presumptuous* is not necessarily doomed, while *pragmatic* and *admirable* take the sentence in the wrong direction. *Contemptuous*, in contrast, makes no sense in the blank’s context. *Futile* is the best choice.

2. **B enamored of**

Choose carefully here. The clue is “the dancers alone made his trip worthwhile.” Thus, Flaubert was impressed by them. *Enamored of* is the only choice that captures such a feeling. *Overwhelmed by* is extreme, and implies that Flaubert got into more than he could handle. *Taken aback by*, in contrast, merely suggests that our traveler was surprised by the dancers; we cannot be sure that his surprise was pleasant. Meanwhile, *beseached by* does not indicate how Flaubert felt, whereas if he were *flustered by* the performers, he would not likely have found his encounter with them *worthwhile*.

3. A fragile and E vulnerability

Try working with the second blank first. The clue is “facade of calm that covers our anxiety.” The trigger *and*

tells you that you are going in the same direction. Therefore, the word in the second blank should be something similar to *anxiety*. *Vulnerability* is the best fit. Nothing in the sentence supports a word as strong as *terror*, and *humor* goes in the wrong direction. For the first blank, if our facade is “flimsy and effortlessly ruptured,” it is likely that the human race is *delicate*. *Fragile* is the only choice that matches.

4. **B prerogative** and **F attainable** by

Try working with the second blank first. The clue is “... when the increased popularity of dime novels, the expansion in the number of bookstores, and the introduction of the paperback made books...” Therefore, find a word for the second blank similar to *accessible*. *Attainable by* is the

best choice. The first blank describes the situation before books became accessible, so buying them would have been a *privilege* limited to the well-to-do. *Prerogative* is the best choice.

5. A an ineluctable and F merely denouement

If district boundaries are designed to *protect incumbents*—that is, those already in office—then *victory* for those incumbents should be close to *assured* or *inevitable*. *Ineluctable* is synonymous with these words. *Invidious* means “causing envy” and *plangent* means “full of lamentation,” neither of which is as well supported as the credited response. The second blank comes after a couple of triggers. The first is *Of course*, which might sound like the passage is continuing in the same direction, but here indicates

a change of direction: The author is conceding that sometimes incumbents face challenges. The second, *Nevertheless*, also changes direction, meaning that the passage has returned to where it started, arguing that elections are essentially decided before they begin. That is what *merely denouement* means. *Seldom nugatory* means rarely inconsequential, which is the opposite of what the passage calls for; *remarkably contentious* is wrong for the same reason, as that phrase would indicate that the general election is fiercely contested.

6. A pedantic and D antediluvian

The first blank describes a group of professors. The clue is that these professors *continue to insist that video games will never be a proper object of study*. The trigger, *while*, also means

that these professors are different from *the rising generation of more heterodox academics*. So, a good word for the first blank is something like *orthodox*. Of the answers, only *pedantic*, which means overly concerned with the formalisms of teaching, comes close to meaning *orthodox*. The second blank describes how the rising generation regards the talk of the first group of professors. Since the rising generation is more heterodox, they would likely regard the view of the more orthodox professors as outdated. The word *antediluvian*—literally, before the flood—means extremely old-fashioned. *Pusillanimous* means cowardly and *jejune* means vapid and immature, so eliminate these choices

7. C fulfilled, F changes, and H perilously

Try working with the first blank first. The clue for the first blank is “predictions generally ... accurate.” The trigger *however* tells you that the first and second parts of the sentence are in contrast to each other. Predictions are usually right, the first part of the sentence is saying, when things go as normal. Put something like *true* in the first blank. *Fulfilled* fits nicely. The second and third blank must be filled together in order to complete the second sentence. The trigger *however* shows that the second sentence changes direction. You would expect predictions to be wrong when there are *changes*, which is a choice for the second blank. *Substantial changes* would make predictions *very* wrong, and *perilously* is the best choice.

8. B dense, F liquid, and G an illustration

The clue for the first blank is the *floating* ice. So, ice is less heavy than water. Only *dense* fits. There is nothing to support that water is more *intriguing* than ice. All solids are less *aqueous* than liquids. For the second blank, the trigger *than* tells you to change direction from *solid*. Another clue is *water* compared to *ice*. Only *liquid* fits. For the third blank, the clue “the floating ice in your water” is offered as an example. Only *an illustration* fits.

9. C practicing, E articulate, and I unfamiliar

For the first blank, Molly *comprehends* Spanish before their trip, so she was *becoming familiar* with Spanish. Only *practicing* fits. *Mastering* goes

too far. Now you can turn your attention to the third blank. Because she is learning Spanish, it must be a *new* language for her, and only *unfamiliar* fits for the third blank. For the second blank, the trigger *although* tells you to change direction from the clue *comprehend*. She could not *state* her thoughts. Only *articulate* means state.

10. **B demarcates, D apocryphal, and I senescence**

The first blank refers to what some people believe about the human lifespan representing the *outer bounds of animal longevity* in relation to that of other animals. So, look for a word that means *marker*. *Demarcates* is the best fit, as *belies* means contradicts, and *antedates* means comes before. The second blank refers to the stories of musket balls being found in turtle

shells and how some people *tend to dismiss tales* about turtles living a long time, so a word such as *questionable* would fit. *Apocryphal* means questionable making it the best choice. The clue for the final blank is that some turtles *show(ing) no signs of aging even as they pass the two-century mark* so look for a word that works with *negligible* to create a phrase that means “not growing old.” *Senescence* means growing old and when combined with *negligible*, is a good fit for this clue.

CHAPTER 5: SENTENCE EQUIVALENCE

Sentence Equivalence Drill

1. C modern and E contemporary

The trigger *or* tells you to change direction from the clue *ancient*. Look for words that mean *modern*. *Modern* and *contemporary* are the only words that mean modern. *Antiquated* and *archaic* are the opposite of what is needed. *Perceptive* and *astute* are a good trap pair because they are similar in meaning and fit the incorrect clue of *observer*, but you do not know that ancient observers were not perceptive or astute.

2. **D innate** and **F inborn**

The blank refers to personality characteristics that interest researchers. The clue is “arise through experience.” Since the sentence is about “nature versus nurture,” we need a word like *nature*. *Innate* and *inborn* fit best.

3. **A capricious** and **D unconventional**

The blank refers to Mackenzie King’s behavior. The clue is “eccentric” which refer to the abnormal behavior of the Prime Minister. *Capricious* and *unconventional* are the only words with a similar meaning. *Repulsive* and *lackluster* don’t fit. *Poised* and *decorous* describe appropriate or formal behavior, so they are more nearly opposites of what’s needed.

4. **B dynamic** and **F oscillating**

The clue *fluctuating* and list of examples tell you that the conditions must be *changing*. *Dynamic* and *oscillating* fit this meaning. None of the other choices fits. *Inveterate* means persisting. *Timorous* and *cowed* mean that the conditions of life are fearful. *Turgid* means complex.

5. **B** *commandeer* and **F** *appropriate*

The main clue is that the armed forces were “without an adequate number of vehicles of their own,” strongly suggesting that they were looking to get some more. Secondary clues are that time was of the essence—“days after Hurricane Zelda had passed”—and the very fact that the subject of the sentence is *armed forces*, a group capable of taking what it wants. This all adds up to something like *seize* for the blank. *Commandeer* and *appropriate*

(the verb, not the adjective) both mean this; none of the other words does.

Sentence Equivalence Practice Set

1. **B affinity** and **F predilection**

The word in the blank is used to describe Jim's feelings for gumdrops. The clues "enjoyed all kinds of candy" and "his absolute favorite" indicates that the blank means *liking*. Both *affinity* and *predilection* mean *liking*. *Odium* and *disregard* go in the wrong direction. *Container* might sound right, but it is not related to the clue. *Nature* does not mean liking.

2. **A fiasco** and **B debacle**

The blank concerns the Wright brothers' first attempt at flying. The clue is that their "subsequent efforts similarly ended in failure." Recycle the clue, and put *failure* in the blank. *Fiasco* and *debacle* are the best matches. *Triumph* and *feat* have the opposite meaning. *Hindrance* is not close enough, and *precedent* does not mean failure.

3. D diminishes and F wanes

The clue "due to the increased aerodynamic drag" suggests that fuel efficiency is likely to decrease as speed increases. *Diminishes* and *wanes* both mean decreases. Eliminate *equalizes* and *stabilizes* because they mean the fuel efficiency evens out. *Adapts* and *increases* do not fit the clue, and neither has a synonym among the other answer choices.

4. **B an inept** and **F a maladroit**

Despite acts as a change-of-direction trigger that, combined with “vast amount of time Francis dedicated to learning six different languages,” tells you that something is wrong with Francis’s communication skills. The last part of the sentence provides an additional clue: “failed to redress his inability to construct cogent prose” means that he doesn’t make sense. The blank must mean *ineffective*, so *inept* and *maladroit* are the best answers. Nothing tells us how Francis feels, so *morose* won’t work. *Astute* is the opposite of what’s needed. Though it’s possible Francis is *florid* and *prolific*, the clues don’t directly support these ideas.

5. **E temperament** and **F humor**

The main clues are that one twin is described as *sanguine*, the other *choleric*; even if you don't know these words, the phrases "even in times of stress" and "angry outbursts" suggest that they are words used to describe *personality*. *Temperament* is a good synonym for *personality*. While it is frequently used to mean comedy, *humor* can also mean personality, especially in conjunction with words such as *sanguine* and *choleric*, which derive from the ancient belief that temperament was shaped by the levels of different fluids, or humors, in a person's body. The remaining choices don't fit: *Environment* means one's surroundings, while the other three words are concerned with the physical rather than the mental.

CHAPTER 6: READING COMPREHENSION

Reading Comprehension Drill

1. A

The passage contains a mixture of information about the aye-aye, both from a scientific and cultural background. It gives an overview of the animal without giving a lot of detail in any one area. Choice (B) is incorrect because the passage mentions evolution only briefly, at the very end. This choice is too narrow. Choice (C) is incorrect because the style of the passage is too advanced for young

students. Choice (D) is incorrect because the passage mentions religion only as it relates to the fate of the aye-aye. Choice (E) is incorrect because the information given is focused more on the aye-aye itself than on the culture of Madagascar.

2. A

The author refers to the aye-aye as a “superb example of life’s variety.” Because this is a positive statement, look for a positive answer. Choice (D) is negative. Choice (E) means sad. Choice (B) means confused. Choice (C) is positive but is too extreme. Therefore, choice (A), *admiring*, is the best answer.

3. **“The aye-aye has been listed as an endangered species and, as a result, the government of**

12/18/1507

Madagascar has designated an island off the northeastern coast of Madagascar as a protected reserve for aye-ayes and other wildlife.”

The author draws the conclusion that the aye-aye may become extinct because the animals are killed on sight and their habitat is being cut down. If some of the animals are in a protected reserve, then not all of them will be affected by the circumstances cited by the author.

4. A and B

Choices (A) and (B) can both be inferred from the passage. Choice (A) is supported by the first paragraph. The classification of the aye-aye changed, which demonstrates that such classifications are not absolute. Choice (B)

is supported by the part of the passage dealing with the future of the aye-aye. It states that the aye-aye is seen as an omen of death in the traditional religion of Madagascar. *Augury* refers to the use of omens, so this statement must be true. Choice (C), however, is not supported. Although the passage states that the aye-aye is in danger, it does not directly discuss whether this is due to limited resources on the main island.

5. A

In the passage, the critics argue that for a piece of literature to be great, it must be hard for the average reader to understand. Answer choice (A) depicts an analogous situation of avant-garde movies deemed superior to Hollywood blockbusters simply because their

storylines are more complicated and presumably harder to understand.

6. E

The passage states, “rather than the to-be-expected socialist harangue, Allende subtly works her political message within the fabric of the compelling narrative she weaves.” In other words, a reader might have expected Allende to include strong socialist propaganda within her novel, but she did not. Answer choice (A) is incorrect. Although the passage talks about Allende’s background, it is not clear that her novel is autobiographical in nature. Answer choice (B) is incorrect because although the passage states that Allende’s work would have received more critical attention if the book had been thought of as great literature, it is not clear that it would

127/1807

have received more favorable reviews. Answer choice (C) is incorrect because although the passage states that Allende borrowed from García Márquez's work, it does not state that she learned magical realism from García Márquez. Answer choice (D) is the opposite of what the passage argues. The passage suggests that it is the very subtlety of her political message that makes Allende's work compelling.

7. E

The passage states, "Yet, to remember the man solely by his associations is to miss his importance to nineteenth-century American philosophy as a whole and to the Transcendental Movement in particular," which suggests the author would agree with answer choice (A). In the second paragraph, the author refers to Alcott as a

“visionary,” which means ahead of his time, so the author would agree with answer choice (B). In the last sentence, the author notes that Alcott believed that “a student’s intellectual growth was concomitant with his or her spiritual growth.” This rules out answer choice (C). In the second paragraph, the author refers to Alcott’s ideas as *polemical* at the time. *Polemical* means controversial, thereby implying that Alcott’s ideas were not universally accepted, which agrees with answer choice (D). The last paragraph of the passage praises Alcott as an erudite orator, a point that is made in direct contrast with his lack of skills as a writer. Therefore, choice (E) is not supported.

8. B

In the first paragraph of the passage, the author states that Alcott's "philosophical treatises have rightly been criticized by many as being ponderous, esoteric, and lacking focus." The term "esoteric" means understood by only a select group. Therefore, the correct answer is choice (B).

9. **B**

Choice (B) is correct. The author states that taxonomic classifications should be used in conjunction with other information about the animal. In choice (B), the team uses both observed and accepted data, which would include classification. Choice (A) is incorrect because the scientists use only taxonomic information. Choice (C) is incorrect because the zookeeper uses only observed information, ignoring the taxonomic information.

10. B

The author tries to convey several facts and make a point about the appropriate use of classifications. Because *didactic* means “intended to instruct,” that’s pretty close. Choice (A) is incorrect because nothing in the passage indicates that the author is upset. Choice (C) is incorrect because the author has a definite opinion on the matter. Choice (D) is incorrect because the author does not sound sad. Choice (E) is incorrect because the passage does not praise anything.

CHAPTER 7: CRITICAL REASONING

Practice: Identifying Conclusions

1. “it is unlikely that the new defense bill will pass”
2. “grass was not a significant part of the dinosaur diet”
3. “automaker *X* will have no choice but to file for bankruptcy”
4. “country *Y* will experience a decrease in obesity-related health problems”

- 12/26/2017
5. “machines will soon outnumber humans as the number-one users of the Internet”

Practice: Finding the Premise

1. **Premise:** A bipartisan group of 15 senators has announced that it does not support the legislation.
2. **Premises:**
 - (1) “The earliest known grass fossils date from approximately 55 million years ago”
 - (2) “Dinosaurs most likely disappeared from the earth around 60 million years ago”

(3) “fossilized remains of dinosaur teeth that indicate the creatures were more suited to eating ferns and palms”

3. Premises:

(1) “company’s poor financial situation”

(2) “the workers at automaker X are threatening to go on strike”

4. Premise: “the leading members of the nation’s food industry have agreed to provide healthier alternatives, reduce sugar and fat content, and reduce advertisements for unhealthy foods”

5. Premise: “Recent advances in technology have led to a new wave of ‘smart’ appliances”

Practice: Locating Assumptions

1. **Conclusion:** There will be no decline in enrollment at the University.

Why?

Premise: The University plans to hire two highly credentialed biology professors to replace Professor Jones.

Assumption: That the two new biology professors will be at least as attractive to prospective students as was Professor Jones.

2. **Conclusion:** It is unjust to charge customers under the age of 25 more to rent a car than those over the age of 25.

Why?

Premise: Most states allow people as young as 16 to have a driver's license and all states allow 18-year-olds the right to vote.

Assumption: Because people under the age of 25 have the right to vote and drive there is no reason to charge them more to rent a car.

3. **Conclusion:** Roughly 12.5 percent of planets in the universe should have life on them

Why?

Premise: In our solar system, there are eight planets and at least one of them has life on it.

Assumption: All planetary systems in the universe have the same

proportion of planets with life on them as does our solar system.

4. **Conclusion:** The leaders of State A should institute the gas tax.

Why?

Premise: 58 percent of voters in Township B approve of a proposed 2--cent gasoline tax.

Assumption: The opinion of Township B is representative of the opinion of all of State A.

Critical Reasoning Practice Set

1. B

Choice (B) indicates that, *overall*, it may not have been financially advantageous in 1989 for a company to move to a region with a lower corporate tax rate. For choice (A), the numbers of similar companies in regions with favorable tax policies compared to the numbers in regions with unfavorable tax policies does not explain why there was less corporate flight. The reference to numbers is out of scope. For choice (C), both the difficulty of the codes and the benefit to anyone other than the company are irrelevant. Though the tax codes may have been difficult to decipher, saving money would still have been good incentive to move. Choice (D) would make it even harder to explain that there was less corporate flight. Some companies would have relocated to foreign

countries. For choice (E), individual tax rates are out of scope.

2. C

You need an answer that describes Tello's response to Aramayo. Aramayo concludes that the government should consolidate its leadership because the government functions most efficiently when decisions are handled by very few individuals. To make such an argument, Aramayo must assume that there are no negative consequences of consolidating the leadership. Tello responds by pointing out a negative consequence. Choice (C) says that Tello responds in such a fashion. For choice (A), Tello does not contradict Aramayo's reasoning, despite offering a possible negative consequence. For choice (B), Tello does more than uncover an assumption: Tello attacks the

assumption. For choice (B) to be correct, Tello's response would have needed to have used words to the effect "But you assume that..." For choice (D), Tello does not uncover any circular reasoning. For choice (E), Tello does not point to any overgeneralization.

3. B

This is really asking for the conclusion of the argument. Choice (B) provides the conclusion. Remember that a properly drawn conclusion should pass the Why Test. Why would hiring a Chief Information Officer improve productivity? Because Chief Information Officers are like new business computer systems, which increase productivity for companies. For choice (A), because the actual function of a Chief Information Officer is never

described in the argument, you cannot conclude anything about that function. Choice (C) contradicts the part of the passage that states “many businesses experience dramatic gains in productivity after installing a new computer system.” For choice (D), the argument provides no basis for comparing the efficiency of a Chief Information Officer and a new computer system. For choice (E), the difficulty of measuring the results is outside the scope of this argument.

4. B

The conclusion is that the clothes washed at the Main Street Laundromat are cleaner than those washed at the Elm Street Laundromat because Main Street uses more water. The premise is that Joe’s clothes are cleaner when he does them at the Main

Street Laundromat and that Main Street's machines use more water per load. This is a causal argument. One way to strengthen a causal argument is to rule out an alternate cause. Choice (B) rules out different detergents as an alternate cause. Choice (A) is just a restatement of the conclusion. For choice (C), the Oak Street Laundromat is out of scope. For choice (D), how much laundry Joe does at each Laundromat is out of scope. Choice (E) would weaken the argument.

5. A

The argument concludes that the change from a multiple-truck delivery system to a single-truck system is the cause of the increase in the rate of complaints. The premise is that the rate of complaints increased and that there had been a change in the method

of delivery. The argument is causal. Choice (A) weakens the argument by providing another cause for the increased rate: Today, the complaints are being reported to the right people. This answer choice leaves open the possibility that the actual number of complaints is unchanged from 1964, but explains why the rate of complaints has risen. For choice (B), whether any mail arrives late in a multiple-truck delivery system is out of scope. For choice (C), registered mail versus unregistered mail is out of scope. For choice (D), because the argument is referring to the rate of complaints, the amount of bulk mail is out of scope. For choice (E), the price of stamps is out of scope.

CHAPTER 8: VOCABULARY FOR THE GRE

Group 1 Exercises: Matching

1. C

2. J

3. E

4. G

5. A

6. L

7. K

8. B

9. N

10. H

11. M

12. I

13. D

14. F

Group 2 Exercises: Matching

1. B

2. M

3. **F**

4. **J**

5. **N**

6. **A**

7. **D**

8. **E**

9. **L**

10. **C**

11. **H**

12. **I**

13. **G**

14. **K**

Group 3 Exercises: Matching

1. **D**

2. **G**

3. **K**

4. **I**

5. **M**

6. **A**

7. **C**

8. **N**

9. H

10. F

11. E

12. B

13. J

14. L

Group 4 Exercises: Matching

1. I

2. L

3. N

4. **C**

5. **K**

6. **B**

7. **J**

8. **A**

9. **G**

10. **E**

11. **M**

12. **D**

13. **H**

14. **F**

CHAPTER 10: NUMBERS AND EQUATIONS

Numbers and Equations Drill

1. C, D, and F

To solve this problem, try writing out the possibilities. The smallest prime number is 2. $(2 \times 2) + 3 = 7$; so answer choice (C) is correct. Answer choice (A) is incorrect because 1 is not a prime number. The next prime number is 3: $(3 \times 3) + 5 = 14$, so answer choice (D) is correct. The next prime number is 5: $(5 \times 5) + 7 = 32$, which is not an answer choice. The next prime number is 7: $(7 \times 7) + 11 = 60$, so

answer choice (F) is correct. The next prime number is 11: $(11 \times 11) + 13 = 134$, which is much larger than the answer choice possibilities. All answer choices have been found.

2. B

First, put the equation in standard form: $x^2 + 8x + 7 = 0$. Now factor: $(x + 7)(x + 1) = 0$. Solve: $x = -7$ or -1 . Both of the possible values for x are negative, so Quantity B is always greater than Quantity A.

3. 27

Because $9 = 3^2$; the original equation becomes $3^3 \times (3^2)^{12} = 3x$; or, $3^3 \times 3^{24} = 3x$; or, $3^{3+24} = 3x$. Therefore, $x = 27$.

4. E

Because there are variables in the answers, Plug In. Let's make $x = 10$, $y = 7$, and $c = 3$. Then $A = 2 \times 10 - (7 - 2 \times 3)$. Order of operations dictates that you solve the numbers in the parentheses before subtracting. $A = 20 - (7 - 6)$. Therefore, $A = 19$. $B = (2 \times 10 - 7) - 2 \times 3$. Again, solve numbers in the parentheses before subtracting. $B = (20 - 7) - 6$. Therefore, $B = 7$. Be careful, the question is asking for $A - B = 19 - 7 = 12$. Plug $y = 7$ and $c = 3$ into the answers. Only answer choice (E) will give you your target, 12. If you chose answer choice (C), you subtracted before you simplified the numbers in the parentheses.

5. A

While the relationship among the can prices is provided, no actual numbers are supplied, so try plugging in some numbers for can prices. The calculations will be easy if you make the large can cost $5 \times 7 = \$35$, which means that the medium can costs $\frac{35}{5} = \$7$, and the small can costs $\frac{35}{7} = \$5$. The amount of money needed to buy 200 medium cans is $200 \times \$7 = \$1,400$. Start Plugging In those answers! Start with C. If the customer buys 72 small cans, that will cost him $72 \times 5 = \$360$. If he buys

72 small cans, they are going to buy 72 large cans so $72 \times 35 = \$2,520$, which is more than the \$1,400 spent on medium cans. This number is too large so eliminate C, D, and E. Try out answer choice A. 35 small cans \times \$5 a can = \$175. 35 large cans \times \$35 = \$1,225. $\$1,225 + \$175 = \$1,400$, the same price as the medium cans. Choice (A) is correct.

6. 25

Stack and add the first two inequalities. Multiple the second inequality by

-1 to make the signs point in the same direction.

$$6k - 5l > 27$$

$$\underline{2k - 3l > 13}$$

$$8k - 8l > 40$$

Divide by 8 to get $k - l > 5$. Multiply by 5 to get final answer of 25. $5k - 5l > 25$.

7. B

This looks like a Plugging In problem, and you could certainly use that strategy here, but sometimes it's easier to manipulate the equation. Translate the equation. $3a = 6b - 4$. Because the question asks for the value of $a - 2b$,

go ahead and rearrange your equation so the a and b are on the same side. $3a - 6b = -4$. Next, divide both sides by 3.

$$3. \frac{3a - 6b}{3} = -\frac{4}{3}.$$

8. C

Answer B seems too easy and it is! To answer this question, first write an equation with the information given. So, *number of cases ordered* \times *\$1,757* = *total amount of money spent*. Now that you have an equation set up, begin figuring out the answer to Quantity

A and the answer to Quantity B. The number of books is equal to *number of cases* $\times 150$, so you can figure out how many cases were sold. Set up the equation and solve. $Cases \times \$1,757 = \$10,550$, so $Cases = \frac{\$10,550}{\$1,757} = 6.004$ cases. You cannot order a partial case, so for \$10,550 you can only order 6 cases, or $6 \times 150 = 900$ books. Solve for Quantity B in the same way. $Cases \times \$1,757 = \$12,290 = \frac{\$12,290}{\$1,757} = 6.99$. Since you cannot order a partial case, once again, only 6 cases can be

ordered and Quantity B equals 6×150 , or 900. The quantities are the same.

9. A and E

To begin, find the factors of 91: 1 and 91 or 7 and 13. Remember that the product of two negative numbers is positive, so the integers could also be negative factors. The question asks for the sum of the two integers. Answer choice (A) is the sum of -91 and -1 . Answer choice (E) is the sum of 7 and 13.

10. E

Since there are variables in the answers, Plug In. If $a = 3$ and $b = 2$, then $x = 9$ and $y = 18$. So, $2(x + y) =$

$2(9 + 18) = 54$. So, 54 is the target. Now, evaluate each answer choice. Choices (A), (B), (C), and (D) all evaluate to 54 and match the target. Choice (E), however, equals 36. Since the question uses the word 'except', choose the answer that doesn't match the target. Choice (E) is the correct answer.

CHAPTER 11: REAL WORLD MATH

Real World Math Drill

1. A

Plug In for r . If $r = 2$, we can now solve for s . $3(2 + s) = 7$, $2 + s = \frac{7}{3}$, $s = \frac{7}{3} - 2$.

Convert the 2 to a fraction and get $s = \frac{7}{3} - \frac{6}{3} = \frac{1}{3}$. Go through the answer choices, Plugging In 2 for r . Choice (A) yields the target of $\frac{1}{3}$. Alternatively,

there is no need to solve all the way for s . Divide the 3 to get $r + s = \frac{7}{3}$. Now subtract r and get $s = \frac{7}{3} - r$.

2. $\frac{1}{6}$

Plugging In your own number is a good way to tackle this. The fractions used in the problem are $\frac{1}{3}$ and $\frac{1}{2}$, and multiplying the denominators will produce a good number with which to work. Sadie started with 6 paintings and gave away one third of them: $6 \times$

$\frac{1}{3} = 2$. She has 4 paintings left. She

then sold another half of the original

6: $6 \times \frac{1}{2} = 3$. So, she has 1 painting

left, or $\frac{1}{6}$ of the total.

3. B, C, and D

A \$20 scarf can be discounted as much

as 50 percent, and $\$20 \times \frac{50}{100} = \10 ,

so the minimum sale price of a scarf is

$\$20 - \$10 = \$10$. The smallest dis-

count is 25 percent, and $\$20 \times \frac{25}{100} =$

$\$5$, so the maximum sale price of a

scarf is $\$20 - \$5 = \$15$. You have determined the range of possible sale prices for scarves is \$10 to \$15. Now, you need to eliminate answers that fall outside of that range: Choice (A) is too small, and choice (E) is too large.

4. B

Don't be intimidated by strange symbols in problems! Just remember to Plug In For Quantity A,

$$\theta 8 = (8^{-3})(16)(4)(2) = \frac{(16)(4)(2)}{8^3}.$$

You could certainly try to multiply this

out but doing so will result in some large numbers and a lot of simplifying, so it is easier to work with the exponents.

$$\frac{(16)(4)(2)}{8^3} = \frac{(2^4)(2^2)(2)}{(2^3)^3} = \frac{2^7}{2^9} = 2^{7-9} = 2^{-2} = \frac{1}{4}$$

. Solve for Quantity B in the same way:

$$4^3 = 4^{-3}(8)(2)(2) = \frac{(2^3)(2)(2)}{(2^2)^3} = \frac{2^5}{2^6} = 2^{-1} = \frac{1}{2}$$

. Quantity B is greater.

5. D

Variables in the question stem means to plug in. For this problem, it's easier to plug in if you simplify the equation first. Rearrange the equation to put the variables on opposite sides of the

equal sign. $8x = 4y$. Then divide both sides by 4 to get that $2x = y$. Now, choose some easy numbers such as $x = 2$ and $y = 4$. In this case, Quantity B is greater, so eliminate answers (A) and (C). Next, try something like $x = 0$ and $y = 0$. In this case, the two quantities are equal. Eliminate choice (B) and the correct answer is (D).

6. D

The population rankings for Year X are as follows: (1) Massachusetts, (2) Connecticut, (3) Maine, (4) Rhode Island, (5) New Hampshire, (6) Vermont. The rankings for Year Y are as follows: (1) Massachusetts; (2) Connecticut; (3) Rhode Island; (4) New Hampshire; (5) Maine; (6) Vermont. Maine, Rhode Island, and New Hampshire have different rankings from Year X to Year Y .

7. D

In Year X , Vermont's population is 5 percent of 15 million (or 0.75 million), and Massachusetts' population is 40 percent of 15 million (or approximately 6 million). 6 million is what percent of 0.75 million? Now translate: 6 million = $\frac{x}{100} \times 0.75$ million: $x = 800$.

8. D

In Year X the population of Rhode Island was 10 percent of 15 million, or 1.5 million. In Year Y the population of Rhode Island was 15 percent of 25 million, or 3.75 million. The increase was 2.25 million, or 2,250,000.

9. C

Start solving this problem by assessing all the information that is given to you in the problem. A 20 gallon water jug is 20% full, so there are 4 gallons in the water jug. The question is asking how many days it will be before the jug is 85% full. 85% of 20 gallons is 17 gallons, so that is the number we are looking for. After the first three days 50% of the total water in the jug is added. There are 4 gallons in the jug, so after three days 2 more gallons are added to the jug to make a total of 6 gallons. After another three days, 50% of 6 gallons is added to the jug, so 3 gallons are added which increases the total amount of water in the jug to 9 gallons. After three more days, 50% of 9 gallons is added to the jug so 4.5 gallons, increasing the total to 13.5 gallons. After another three days the total

is increased by 50% of 13.5, which is 6.75 gallons, which will increase the total to more than 17 gallons. So there were 4 increases of three days apiece, for a total of 12 days, answer choice (C).

10. A

Towns *A* and *B* have 3,000 supporters each. Towns *B* and *D* have an average of 3,500 supporters. Any time the word average appears, start thinking about setting up an average pie. There is an average of 3,500 and 2 towns, so the total is 7,000 supporters. Town *B* has 3,000 supporters, so Town *D* has

$7,000 - 3,000 = 4,000$ supporters. Towns A and C have an average of 5,000 supporters, so make another average pie. There are 2 towns and an average of 5,000 supporters, so there is a total of 10,000 supporters. Town A has 3,000 supporters so Town C has $10,000 - 3,000 = 7,000$ supporters. Quantity A is the average of Towns C and D so $7,000 + \frac{4,000}{2} = 5,500$ supporters. Quantity B is the average of Towns B and C so $3,000 + \frac{7,000}{2} = 5,000$. Quantity A is greater.

11. E

Plug In The Answers, starting in the middle with choice (C). If each A employee was given \$740, each C employee was given half of that, or \$370. Each B employee received one-and-a-half times the C raise, so $1.5 \times \$370 = \555 . Now calculate the total money spent on raises. 50 A employees got \$740 each, for a total of $50 \times \$740 = \$37,000$. 100 B employees got \$555 each, for a total of $100 \times \$555 = \$55,500$. 150 C employees got \$370 each: $150 \times \$370 = 55,500$. These add up to a total of \$148,000, but the problem says that the total raise amount is \$500,000. You need a much bigger answer. Rule out choices (A), (B), and (C). Try skipping directly to (E). If the A workers got \$2,500, the C workers got \$1,250, and the B workers got \$1,875. $50 \times \$2,500 =$

\$125,000; $100 \times \$1,875 = \$187,500$; and $150 \times \$1,250 = \$187,500$. Because these numbers add up to \$500,000, choice (E) is correct.

12. 19

Plug In \$100 for the price the retailer pays for the item. Therefore, the original selling price is \$140, or 40 percent more than the retail price. To find the reduced selling price, subtract 15 percent of \$140 from \$140 to get \$119. The retailer's profit (selling price – cost) is \$19. Translating the last line of the question, we get $\$19 = (x \div 100) \times 100$, or 19 percent.

13. B

Median means middle. In other words, if you put all the ninth graders in order by score, the middle student would

have the median score. Thinking in terms of percentiles, the 50th percentile is the middle, so on the ninth grade pie chart, whatever score includes the 50th percentile when you put the scores in order is the median score. According to the chart, 16 percent of the ninth graders scored below 65, and 37 percent scored between 65 and 69 points. $16 \text{ percent} + 37 \text{ percent} = 53 \text{ percent}$. The 50th percentile, then, falls within the group that received 65–69, so 65–69 is the median score.

14. **A**

In 1995 there were $1,350 + 950 + 625 + 500$, or $\approx 3,400$ students in grades 9 through 12. 3,400 is 35 percent of

1266/1507

School District X, so $3,400 = \frac{35}{100} \cdot x$, x
 $\approx 9,700$, so there were 9,700 students.

15. **E**

There were 1,200 ninth graders in 2013. 25 percent of them, or 300, scored in the 70–79 point range. 14 percent, or 168, scored in the 80–89 point range. The difference between 300 and 168 is 132. (E) is the closest choice.

16. **D**

You cannot combine an equation and an inequality, so start by assessing the information provided. The inequality

can be simplified by distributing $\frac{1}{2}$ to get $6x - 6y > 0$. So, $6x > 6y$ or $x > y$. Now, plug some numbers into the equation but remember that $x > y$. If $y = 0$, then $x = 21$, eliminate choices (A) and (B). However, if $y = 0.5$, then $x = 20$. Eliminate answer choice (C). Answer choice (D) is correct.

17. D

Use several ratio boxes on this problem. Because one ounce of Solution X has 2 parts of a and 3 parts of b , there are 5 parts total for X , while one ounce of Solution Y has $1 + 2 = 3$ parts total. Convert these ratios so that they have

the same total, which will allow you to compare them. Multiply Solution X by 3 and Solution Y by 5 so that each have 15 total. The new Solution X is 6 parts a and 9 parts b , and the new Solution Y is 5 parts a and 10 parts b . For solution Z there are 3 parts X , so $3 \times 6 = 18$ parts a and $3 \times 9 = 27$ parts b . There are 11 parts of Y in Z , so there are $11 \times 5 = 55$ parts a and $11 \times 10 = 110$ parts b . Thus, Solution Z has $18 + 55 = 73$ parts a and $27 + 110 = 137$ parts b , and $73 + 137 = 210$ total in the ratio. Because the actual total is 630, which is 210×3 , there must be $73 \times 3 = 219$ parts of a in the final Solution of Z .

The library has 160 books on Sunday. Monday's total is $160 - 40$, or 120. Tuesday is $120 + \left(\frac{1}{2} \times 40\right)$, or 140. Wednesday is $140 + \left(\frac{1}{2} \times 20\right) - 20$, or 130. Thursday is $130 + 80 + \left(\frac{1}{6} \times 30\right)$, or 215. Friday and Saturday see 65 more books leave, so the total for the end of Saturday is $215 - 65 = 150$. Note that the question asks for Monday, not the first Sunday. The percent change from Monday to Saturday is $\frac{(150 - 120)}{120} \times 100$, or 25 percent.

CHAPTER 12: GEOMETRY

Geometry Drill

1. A, B, and C

You need to check if the two angles in each answer choice can be part of a right triangle. A right triangle has a 90-degree angle, and because the sum of all the angles of a triangle is 180 degrees, the sum of the other two angles must equal $180 - 90 = 90$ degrees. In answer choice (A), $20 + 70 = 90$ degrees, so these could be the other two angles in a right triangle. Answer choices (B) and (C) also add up to 90 degrees, and so they are correct as well. In choices (D) and (E), the two

angles have a sum greater than 90 degrees, so they are incorrect.

2. B

To find the perimeter of the figure, you need to add up all of its external sides. As written, you're missing the measure of one side of the rectangle. Because the side of the rectangle is equal to the hypotenuse of the right triangle, use the triangle to find the missing side. To find the hypotenuse of the right triangle recognize the common right triangle (5 : 12 : 13), or use the Pythagorean Theorem ($5^2 + 12^2 = x^2$). The missing side of the rectangle is 13. Therefore, the perimeter equals $5 + 12 + 17 + 13 + 17 = 64$. Answer choice (A) is the perimeter without the missing side of the rectangle. If you chose answer choice (D), you included an interior side of the rectangle.

3. A

We know that the triangle EFG is equilateral because all three angles are equal. That means all of its sides equal 8. From the first equation, we know that the sides of the square also equal 8. The area of the square is $s \times s = 8 \times 8 = 64$, which is larger than Quantity B.

4. D

Draw it on your scratch paper, and plot the points. Both a and b must be positive, but their values could be equal or unequal. Quadrant I has $(+, +)$ coordinates, Quadrant II has $(-, +)$ coordinates, Quadrant III has $(-, -)$ coordinates, and Quadrant IV has $(+, -)$ coordinates.

5. E

There are variables in the answers, so Plug In. If the shorter piece is 2 yards long, then the longer piece is $3(2) + 2 = 8$ yards and t must be $2 + 8 = 10$. The target answer, the length of the longer piece, is 8. Plug In 10 for t into all of the answers. Answer choice (E) is the only answer choice that matches your target of 8.

6. D

If CD , the radius of the smaller circle, is 3, then the diameter of the smaller circle is 6. The diameter of the smaller circle is equal to the radius of the larger circle because the smaller circle touches the center and the edge of the larger circle. The formula for the area of a circle is πr^2 , so the area of the larger circle is 36π . To find the area of the semicircle, divide by 2 to find 18π .

7. 2

Draw it! If Karl starts x meters below the boat and swims straight down for 8 meters, he is now $x + 8$ meters below the boat. He swims 24 meters to his right and then swims 26 meters in a direct line back to the boat. This drawing should look like a triangle with sides $x + 8$, 24, and a hypotenuse of 26. Use the Pythagorean Theorem to solve for x , or using special right triangles, realize that this is a 5, 12, 13 triangle multiplied by 2. $x + 8$ has to equal 10, so $x = 2$.

8. A

This is a Plug In problem. Make $r = 2$. The circumference of the circle will be $4(\pi)$, which is approximately 12. The perimeter of the square is $2 + 2 + 2 + 2 = 8$. Quantity A is greater. Try

Plugging In other numbers and you will see that Quantity A will always be greater.

9. C

The area of the circle is 25π , so the radius of the circle is 5. This means that both AC and BC have length 5, and angles A and B are equal to each other. Because angle C is 60° and the total angle measure of a triangle is 180° , the sum of angle A and B must be 120° . Thus, each angle in triangle ABC is 60° , making this is an equilateral triangle. An equilateral triangle has equal sides and equal angles, so the only possible length of the triangle legs is 5.

10. A

Remember the third side rule. The third side of a triangle must be less than the sum of the other two sides of a triangle, but greater than the difference. That gives us a clear range for x . It must be greater than 6 but less than 12. Quantity A, therefore, is greater than Quantity B; the answer is (A).

11. **A**

You can see that the two triangles are almost the same, except that the base length in the triangle to the right is slightly larger. Remember, on Quant Comp problems you cannot trust the figure to be drawn to scale. If you look at these triangles and expand the base length, the triangle on the right starts to collapse and its height gets smaller and smaller. Thus, height f must be greater than height g . This technique

works quite well in a number of GRE quant comp geometry problems!

12. B

In order to find the x -coordinate of a point on a line, you must first find the slope of the line. Notice that along with points A and B , the origin is also a point on the line in the figure. Using the coordinates of $(0, 0)$ and $A(2, 3)$, the slope is $\frac{(y_2 - y_1)}{(x_2 - x_1)} = \frac{3}{2}$. Because the slope of a line stays constant, you can use the value you just found to solve for the missing x -coordinate of point

B. Using points $A(2, 3)$ and $B(x, 4.2)$, solve $\frac{(4.2 - 3)}{(x - 2)} = \frac{3}{2}$. Cross-multiply to find that $3x - 2 = 2.4$, so $x = 2.8$ or choice (B).

13. A

Use the $3 : 4 : 5$ ratio or the Pythagorean theorem to determine that the length of AB is 4. Because the area of a triangle equals $\frac{1}{2} \times \text{base} \times \text{height}$, triangle ABD has an area of $\frac{1}{2} \times 3 \times 4$, or 6. Be wary of answer choice (D), which is the area of the rectangle.

14. B

Because the two angles have the same measure, the wedges of the circle they mark off will have the same area. The triangle is smaller than the wedge, so Quantity B is greater than Quantity A.

15. C

Because $LMNO$ is a parallelogram and $\angle OLM = 108^\circ$, $\angle LON$ must be $180^\circ - 108^\circ = 72^\circ$. $\angle LON$ is the same fraction of the entire circle (360 degrees) that arc AB is of the entire circumference, so $\frac{72}{360} = \frac{1}{5}$. Thus, arc AB is $\frac{1}{5}$ of the circumference. So, $\frac{1}{5} \times 15\pi = 3\pi$.

CHAPTER 13: MATH ET CETERA

Et Cetera Drill

1. C

If there is one more red marble than blue, there must be 7 blue marbles and 8 red ones, for a total of 15. The probability of choosing a blue marble is $\frac{\text{\# of blue marbles}}{\text{Total \# of marbles}}$, or $\frac{7}{15}$. If you selected choice (E), you probably computed the probability of drawing a red

marble rather than the probability of drawing a blue one.

2. D

Plug the values into the function. First, find $Y(5)$: $(5 \times 10 - 1) = 49$. Next, find $Y(3) = (3 \times 10 - 1) = 29$. Now subtract them: $Y(5) - Y(3) = 49 - 29 = 20$.

3. A

Find all the factors of 78. $78 = 1 \times 78 = 2 \times 39 = 3 \times 26 = 6 \times 13$. The largest odd factor is 39; the largest prime factor is 13. Quantity A is greater than Quantity B.

4. 20

Remember, in this problem order matters, so do not divide! All 5 finalists

could be awarded “Best in Show.” There are 4 choices left for “Honorable Mention,” because a different dog must be chosen. Therefore, the total number of possibilities is 5×4 , or 20.

5. A

Use the group equation: Group 1 + Group 2 - Both + Neither = Total. So, $\$40,000 + \$30,000 - \$15,000 + \text{Neither} = \$90,000$. Thus, $\$55,000 + \text{Neither} = \$90,000$. So, the company budgets $\$35,000$ on other products. Quantity A is greater than Quantity B.

6. B

List the two-digit prime numbers less than 50: 11, 13, 17, 19, 23, 29, 31, 37, 41, 43, and 47. The numbers in which the tens digit is greater than the units digit are 31, 41, and 43. Because 3 out

of the 11 possibilities meet the requirement, choice (B) is correct.

7. A

Plug In the answer choices, starting with C. With 9 staff members, the elec-

ted official has $\frac{9 \times 8 \times 7 \times 6 \times 5}{5 \times 4 \times 3 \times 2 \times 1}$ op-

tions. This works out to 126, which is

too large. Try Plugging In answer

choice A. With 7 staff members, the

elected official has $\frac{7 \times 6 \times 5 \times 4 \times 3}{5 \times 4 \times 3 \times 2 \times 1} =$

21 different groups of 5 from which to

choose.

8. E

Plug In: Make $x = 2$ and $y = 3$. Now $x \# y = 2(2 - 3) = -2$. Watch out for traps: Answer choices (A) and (C) will give you -2 , but because the question asks for $x \# (x \# y)$, you need to perform the operation again. $2 \# (-2) = 2[2 - (-2)] = 2(4) = 8$. Now put $x = 2$ and $y = 3$ into the answer choices to find a match for your target answer, 8. Be sure to eliminate choices (A), (B), (C), and (D) as soon as you realize they are negative. The only answer that matches is choice (E).

9. B

Use a ratio box to find that if there are twice as many yellow as green and 12 total, then there are 8 yellows and 4 greens. Two situations would fit the

requirements of the problem: Pull out a yellow and then green, or pull out a green and then yellow. So, find the probability of each of these situations; then add these two probabilities together. The probability of yellow and then green is $\frac{8}{12} \times \frac{4}{11} = \frac{8}{33}$. The probability of green and then yellow is $\frac{4}{12} \times \frac{8}{11} = \frac{8}{33}$. Add these two probabilities to find $\frac{8}{33} + \frac{8}{33} = \frac{16}{33}$.

10. B

You could try to draw this all out, but it is easier to do the math. For Quantity A, if you're creating triangles, you're really choosing three points from the set of 10. This is a combination problem—order doesn't matter, because triangle ABC would be the same as triangle BCA . You could use the formula $\frac{10 \times 9 \times 8}{3 \times 2 \times 1}$. For Quantity B, note that quadrilaterals are any four-sided figures, so you're just choosing 4 points from 10. You could use the

formula for combinations:

$$\frac{10 \times 9 \times 8 \times 7}{4 \times 3 \times 2 \times 1} = 210.$$

Comprehensive Math Drill

1. B

Any line that is tangent to a circle makes a 90 degree angle with the radius of that circle at the point of tangency. The radius of the circle is 5, so the length of line segment AC is also 5. The side opposite the 90 degree angle is BC and this measures $\frac{10\sqrt{3}}{3}$. If you know the special right triangles, you

should be able to recognize that the sides are in the ratio of a 30:60:90 triangle. The ratio of the sides in a 30:60:90 triangle is $x:x\sqrt{3}:2x$, respectively. If $2x = \frac{10\sqrt{3}}{3}$, then $x = \frac{5\sqrt{3}}{3}$. The length of line segment AB , then, is $\frac{5\sqrt{3}}{3}$, and line segment AC is the radius of the circle, or 5. Quantity B is greater.

2. C

Plug in and simplify both expressions.

Make $x = 2$. $\frac{2}{5} = \frac{2}{5} \times \frac{1}{2} = \frac{2}{10}$. This is the

same value as is under quantity A. The answers are equal.

3. C

Remember that the percentages for standard deviations are 34 percent, 14 percent, 2 percent in both directions from the mean. If the mean is 50, then 34 percent score between 50 and 54, 14 percent score between 54 and 58, and 2 percent score above 58. The same idea applies in the other direction: If the mean is 50, then 34 percent score between 50 and 46, 14 percent score between 46 and 42, and 2 percent score below 42. So, both quantities are equal to 2 percent.

4. A

The equation $y = mx + b$ describes a line where m is the slope and b is the y -intercept—the place where the line crosses the y -axis. Hence, the y -intercept of our line, or P , is $(0, 1)$, which means the length of OP is 1. Because Q is on the x -axis, the y -coordinate must be 0, and we can use the line equation to solve for x : $0 = -\frac{5}{6}x + 1$, so $-1 = -\frac{5}{6}x$, and $x = \frac{6}{5}$. That means $OQ = \frac{6}{5}$, and Quantity A is greater. Because this is a Quant Comp, though, we can actually compare the quantities without

solving them. If you recognize from the line equation that our slope is $-\frac{5}{6}$, and you remember that slope is defined as $\frac{\text{rise}}{\text{run}}$, you might also recognize that Quantity A, OQ , is our run, and Quantity B, OP , is our rise. Disregarding the negative sign—distance is always an absolute value, and therefore positive—we can see that our rise is less than our run, and Quantity A is greater.

5. B

For Quantity A, “pairs” tells you that you’re picking two and that order does not matter so divide. You could use the formula $\frac{20 \times 19}{2 \times 1} = 190$. For Quantity B, the “rankings” tells you that order matters so do not divide. So, you could use the formula $10 \times 9 \times 8 = 720$.

6. D

The denominator is the same for both expressions, so we only need to compare numerators to determine which fraction is greater. Plug In to see whether kl is greater than or less than 1. Let $k = 0.5$ and $l = 1.5$. Therefore, $kl = 0.75$. Eliminate answer choices (B)

and (C). Now let $k = 10$ and $l = 10$, $kl = 100$. Eliminate answer choice (A).

7. A

Start assessing the information in the statement before working with the quantities to solve this problem. A jeweler made \$800 on the discounted sale price of a diamond that cost the jeweler \$5,400, so the discounted price of the diamond is \$6,200. The profit from the discounted price (\$800) is 80% less than the profit from the regular, undiscounted price.

That is just another way of saying \$800 is 20% of what number. Set up the equation to find that $800 = \frac{20}{100}x$, so $x = \$4,000$. Quantity A is asking for the profit the jeweler would have made from the sale of the diamond before the discounted sale price expressed as a percentage of the cost. So the profit of \$4,000 is what percentage of \$5,400. Again, set up the equation to find that $\$4,000 = \frac{x}{100} 5,000$, so = 80%. Quantity B asks for the difference between the profit from the

discounted price and the profit from the regular, undiscounted price before the discount expressed as a percentage of the regular, undiscounted price. Find the difference between the profits, which is $4,000 - 800 = 3,200$. The original sale price is the cost of the diamond to the jeweler plus the profit on the regular, undiscounted price, so $5,400 + 4,000 = 9,400$. So quantity B is $3,200 = \frac{x}{100} 9,400$, so $x = 34\%$. Quantity A is greater.

If Joe starts with \$200 and spends \$150 on a CD player, he has only \$200 - \$150 = \$50 left. Each CD is \$12, so divide \$50 by \$12. It goes in 4 times with \$2 left over. Don't round! Joe can buy only 4.

9. A

For triangle ABC , the base is the difference between A and C , 1. Finding the height is a little more difficult. The height of a triangle is any perpendicular line dropped from the highest point to the level of the base. The height does not need to touch segment AC as long as it extends from B to the

level of AC . For this triangle, distance from B to the origin is the height, 4. Plug In the base and height: Area = $\frac{1}{2} \times 1 \times 4 = 2$.

10. A

When you have a large number that needs to be divided, the best way to begin answering the question is the break that number down into its prime factors. So $10(9^6) = 2 \times 5 \times (3^2)^6$, or $2 \times 5 \times 3^{12}$. Therefore, the prime factorization of any number that $10(9^6)$ can be divided by can contain no more than one 2, one 5, and twelve 3s. Only answer (A), 90, meets these requirements. For example, the prime factorization of answer (D), 540, includes

two 2s so $10(9^6)$ is not divisible by 540. Answer (A) is correct.

11. B and C

Roberta's rate is 50 miles in 2 hours. Notice that the first number in this proportion is greater than the second. Use that to eliminate choices (A) and (D). For choice (B), $\frac{100}{4} = \frac{50}{2}$, so this is the same as the original proportion. For choice (C), $\frac{400}{16} = \frac{50}{2}$, so this is also the same as the original proportion. Answer choice E does not

produce this same proportion, so eliminate it as well.

12. C

There were seven cities with temperatures in Year Y *higher than or equal to those in Year X* : Baltimore, Detroit, Las Vegas, Minneapolis, New York, Phoenix, and San Francisco.

13. C

The lowest average temperature was 34° F in Anchorage, and the highest was 83° F in Las Vegas. Percent change = $\frac{\text{difference}}{\text{original}} = \frac{49}{34} \approx 144$ percent.

14. C

You're averaging the highs and lows for Years X and Y , so the number of things is 4. The bar shows the average of Years X and Y , which reads 60. Multiply 60 by 4 to get the total, 240. Get the average high temperatures for Years X and Y from the straight and dotted lines on the chart. They're about 103 degrees and 97 degrees. The total is $240 = 103 + 97 + \text{low Year } X + \text{low Year } Y$. If you subtract the highs from the total, you're left with 40 degrees as the total for the lows. Because you want the average of the lows, divide this total by 2. The closest answer is 20° .

15. A, B, and C

First, simplify the inequality by subtracting 2 from both sides: $|2x - 3| >$

5. Now plug each answer choice into the inequality to see which value of x makes the inequality true. The correct values are those in choices (A), (B), and (C).

16. **A**

The question states that x is an odd integer, so eliminate choice (C) because 0 is not odd. Simplify $x + y + z < z$ by subtracting z from each side: $x + y < 0$. Because x is less than y , x must be negative so that when added to y , the answer will be less than zero. Therefore, eliminate choices (D) and (E). Now Plug In the remaining answers to see which value of x will work in the inequality. Choice (A) is the only choice that works.

17. **E**

First, solve for x by multiplying 4 by itself until you get 1024. This means that x equals 5. If you substitute 5 for x in the second equation, the equation reads, $4^6 \times 5^4$. Because the answers are expressed in terms of 4^n , 5^n , and 10^n , expand out $4^6 \times 5^4$ to get $4 \times 4 \times 4 \times 4 \times 4 \times 4 \times 5 \times 5 \times 5 \times 5$. Now try to express it using 10^n . We need to factor two of the fours and rewrite this as $4 \times 4 \times 4 \times 4 \times 2 \times 2 \times 2 \times 2 \times 5 \times 5 \times 5 \times 5$. Now, convert this back into exponents to get $4^4 \times 2^4 \times 5^4$, or $4^4 \times 10^4$.

18. D

First, use the volume formula to find the width: $V = l \times w \times h$. So, $780 = 12 \times w \times 5$. Thus, the width is 13. Next, draw the figure. Notice that the greatest distance is from one corner to the opposite corner, such as from the

front left bottom corner diagonally to the rear right top corner. You can use the formula for diagonal of a rectangular solid, $a^2 + b^2 + c^2 = d^2$, in which a , b , and c are the dimensions of the rectangular solid and d is the diagonal, and love that you have a calculator. Thus, $(5)^2 + (12)^2 + (13)^2 = d^2$. So, $25 + 144 + 169 = d^2$, and thus $d = \sqrt{338}$ or $13\sqrt{2}$.

19. D

There are six spots to fill. Because no boys can sit on the end of the bench, 3 girls are available to fill one spot at one end of the bench. Once one girl has been chosen to fill that spot, there are 2 girls available to fill the spot on the other end of the bench. Then, there are 4 children (boys and girls) available to fill the other four spots.

Because $3 \times 2 \times 4 \times 3 \times 2 \times 1 = 144$, choice (D) is correct.

20. C

Use the average pie. If 16 is the average of 3 numbers, their total is 48. You know that one of the numbers is 24, so $p + q + 24 = 48$. Thus, $(p + q) = 24$. You need to find $16(p + q)$, so find $16(24)$, which equals 384.

Part VI

The Princeton
Review GRE
Practice Tests and
Explanations

[17 Practice Test 1](#)

[18 Answers and Explanations
for Practice Test 1](#)

[19 Practice Test 2](#)

[20 Answers and Explanations
for Practice Test 2](#)

TEST INSTRUCTIONS

It's important to become familiar with the instructions for the test now, so that you don't waste time figuring them out on test day.



Need more practice?

The Princeton Review's
1,007 GRE Practice
Questions, Fourth Edition
offers drills for every
question type, along with
detailed, comprehensive
explanations.

General Instructions

Each exam consists of six sections—two Analytical Writing sections, two Verbal Reasoning sections, and two Quantitative Reasoning sections. The Analytical Writing sections will always be first. The Verbal and Quantitative Reasoning sections may appear in any order. You will have 30 minutes for each Analytic Writing section, 30 minutes for each Verbal, and 35 minutes for each Quantitative Reasoning section. If desired, you may take a 10-minute break after Section 4. Remember that during the actual test, there may be an additional verbal or quantitative experimental section.

Section 1	30 minutes	Analytical Writing
Section 2	30 minutes	Analytical Writing

Section 3	30/35 minutes	Verbal or Quantitative Reasoning
Section 4	30/35 minutes	Verbal or Quantitative Reasoning
Section 5	30/35 minutes	Verbal or Quantitative Reasoning
Section 6	30/35 minutes	Verbal or Quantitative Reasoning

When taking a Verbal or Quantitative Reasoning section, you are free to skip questions that you might have difficulty answering and come back to them later during the time allotted for that section. You may also change your response to any question in a section during the time allotted to work on that section. You may not go back to an earlier section of the test after time for that section runs out.

Analytical Writing Instructions

Issue Topic

You will be given a brief statement on an issue of general interest and specific instructions on how to respond to that issue. You will have 30 minutes to plan and write a response in which you develop a position on the issue. Make sure that you respond to the specific instructions and support your position on the issue with reasons and examples drawn from such areas as your reading, experience, observations, and/or academic studies.

Before you begin writing, you may want to think for a few minutes about the passage and the instructions and then outline your response. Be sure to develop your analysis fully and organize it coherently. Leave a

minute or two at the end to reread what you have written and make any revisions you think are necessary.

Argument Topic

You will be given a short passage that presents an argument, or an argument to be completed, and specific instructions on how to respond to that passage. You will have 30 minutes to plan and write a response in which you analyze the passage. Note that you are NOT being asked to present your own views on the subject. Make sure that you respond to the specific instructions and support your analysis with relevant reasons and/or examples.

Before you begin writing, you may want to think for a few minutes about the passage and the instructions and then outline your response. Be sure to develop your analysis fully and organize it coherently. Leave a

minute or two at the end to reread what you have written and make any revisions you think are necessary.

Verbal Reasoning Instructions

Each Verbal Reasoning section is 30 minutes long and has 20 questions. For some questions, you will be instructed to choose one or more answer choices. The instructions may or may not specify the number of answers you must choose. If the number of answers is specified, you must choose all of the correct answers in order to have your response counted as correct. If the number is not specified, choose all that correctly answer the question. No credit will be given if fewer or more than all of the correct answers are chosen.

Quantitative Reasoning

Instructions

Each Quantitative Reasoning section is 35 minutes long and has 20 questions. You will be provided with a five-function calculator—one with addition, subtraction, multiplication, division, and square-root features—during Quantitative Reasoning sections.

For some questions, you will be instructed to choose one or more answer choices. The instructions may or may not specify the number of answers you must choose. If the number of answers is specified, you must choose all of the correct answers in order to have your response counted as correct. If the number is not specified, choose all that correctly answer the question. No credit will be given if fewer or more than all of the correct answers are chosen.

Some questions will require you to enter your own answer. If the question provides a single response space, enter a single number. You may enter negative signs and decimal points. If the question tells you to round your answer, do so. Otherwise, enter the entire answer. If the question provides two response spaces, you must enter your answer in the form of a fraction. You are not required to enter fractions in their most reduced form. If you are aware of more than one correct response, you should enter only one of them.

Some questions will ask you to fill blanks in the text by clicking to select from a list of choices. Sometimes all of the choices will be used, and sometimes only some of the choices will be used. The correct answer always requires you to put a different choice in every blank.

Note on Numbers and Figures

Numbers: All numbers used are real numbers.

Figures: The position of points, angles, regions, and so on can be assumed to be in the order shown, and angle measures can be assumed to be positive. Lines shown as straight can be assumed to be straight. Figures can be assumed to lie in a plane unless otherwise indicated. Any other figures are not necessarily drawn to scale, unless a note states that a figure is drawn to scale.

Chapter 17

Practice Test 1

Click [here](#) to download a PDF of Practice Test 1.

SECTION 1: ISSUE TOPIC

Directions:

You will be given a brief quotation that states or implies an issue of general interest and specific instructions on how to respond to that issue. You will have 30 minutes to plan and compose a response in which you develop a position on the issue according to the specific instructions. A response to any other issue will receive a score of zero.

“Governments are justified in circumventing civil laws when doing so is vital to the protection of national security.”

Write an essay in which you take a position on the statement above. In developing and supporting your position, you should consider ways in which the statement might or might not hold true.

SECTION 2: ARGUMENT TOPIC

Directions:

You will be given a short passage that presents an argument, or an argument to be completed, and specific instructions on how to respond to that passage. You will have 30 minutes to plan and compose a response in which you analyze the passage according to the specific instructions. A response to any other argument will receive a score of zero.

Note that you are NOT being asked to present your own views on the subject. Make sure that you respond to the specific instructions and support your analysis with relevant reasons and/or examples.

The following is from a recent email from the Diord Corp. Human Resources Manager: “Tobor

Technologies found that mental health problems and mental illness were responsible for about 15 percent of employee sick days. Tobor amended its employee insurance plan so that workers receive the same coverage for mental illness as they do for physical illness. In addition, the company hired an on-site psychologist and created a system that allows workers to schedule confidential counseling appointments. After one year, the number of sick days used by employees declined by 10 percent. Diord Corp. has had an increase in employee sick days over the past two years, so we should introduce a similar insurance plan and counseling program. These measures will surely reduce employee absenteeism and cause an increase in productivity.”

Write a response in which you examine the argument’s unstated assumptions, making sure to explain how the argument depends on the assumptions and what the implications are if the assumptions prove unwarranted.

SECTION 3: QUANTITATIVE REASONING

For each of Questions 1 to 7, compare Quantity A and Quantity B, using additional information centered above the two quantities if such information is given. Select one of the following four answer choices and fill in the corresponding circle to the right of the question.

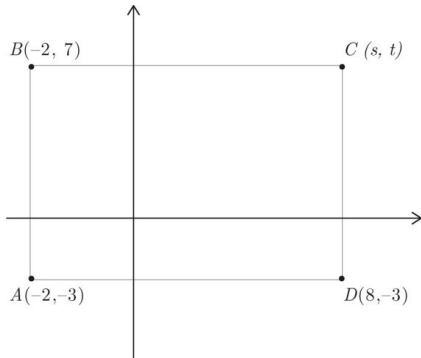

Quantity A

s

Quantity B

t

- Quantity A is greater.
- Quantity B is greater.
- The two quantities are equal.
- The relationship cannot be determined from the information given.

A certain punch is created by mixing two parts soda and three parts ice cream. The soda is 4 parts sugar, 5 parts citric acid, and 11 parts other ingredients. The ice cream is 3 parts sugar, 2 parts citric acid, and 15 parts other ingredients.

Quantity A**Quantity B**

Parts sugar in the punch

Parts citric acid in the punch

- Quantity A is greater.
- Quantity B is greater.
- The two quantities are equal.
- The relationship cannot be determined from the information given.

3 of 20

The average (arithmetic mean) high temperature for x days is 70 degrees. The addition of one day with a high temperature of 75 degrees increases the average to 71 degrees.

Quantity A

Quantity B

x

5

- Quantity A is greater.
- Quantity B is greater.
- The two quantities are equal.
- The relationship cannot be determined from the information given.

4 of 20

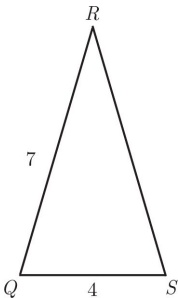

Each angle in $\triangle QRS$ has a degree measurement of either x or y and the angles are expressed by the equation $2x + y = 180$

Quantity A

Quantity B

Perimeter of QRS

17

- Quantity A is greater.
- Quantity B is greater.
- The two quantities are equal.

- The relationship cannot be determined from the information given.

5 of 20

The scores for the 500 students who took Ms. Johnson's final exam have a normal distribution. There are 80 students who scored at least 92 points out of a possible 100 total points and 10 students who scored at or below 56.

Quantity A

Quantity B

The average
(arithmetic mean)
score on the final
exam

87

- Quantity A is greater.
- Quantity B is greater.

- The two quantities are equal.
- The relationship cannot be determined from the information given.

6 of 20

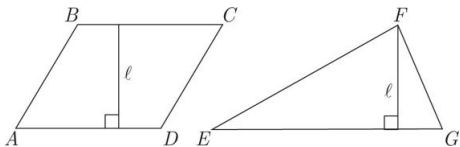

AB is parallel to CD .

AD is parallel to BC .

$$2AD = EG$$

Quantity A

The area of
 $ABCD$

Quantity B

The area of EFG

- Quantity A is greater.

- 13/26/1807
- Quantity B is greater.
 - The two quantities are equal.
 - The relationship cannot be determined from the information given.

7 of 20

$$(3x - 4y)(3x + 4y) = 2$$

Quantity A

Quantity B

$$9x^2 - 16y^2$$

$$4$$

- Quantity A is greater.
- Quantity B is greater.
- The two quantities are equal.
- The relationship cannot be determined from the information given.

8 of 20

If $8a - 2 = 22$, then $4a - 1 =$

- 2
- $\frac{11}{4}$
- 11
- 12
- 44

9 of 20

Twenty percent of the sweaters in a store are white. Of the remaining sweaters, 40 percent are brown, and the rest are blue. If there are 200 sweaters in the store, then how many more blue sweaters than white sweaters are in the store?

Click on the answer box and type in a number.

Backspace to erase.

[10](#) of 20

$$\frac{4^{13} - 4^{12}}{4^{11}} =$$

- 0
- 1
- 4
- 12
- 16

Questions 11 through 14 refer to the following graph.

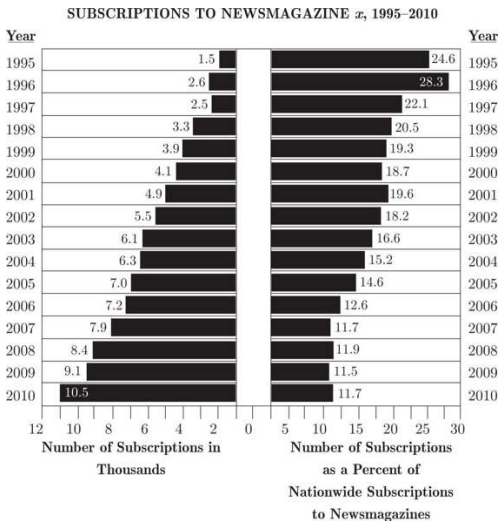

Note: Drawn to scale

NATIONWIDE NEWSMAGAZINE SUBSCRIPTIONS:
1997 TO 2009

Newsmagazine	1997	2000	2003	2006	2009
x	2,500	4,100	6,100	7,200	9,100
y	1,700	3,100	4,600	5,700	7,200
z	3,600	5,800	7,600	9,400	11,400
Others	3,500	8,900	18,500	34,700	51,300

[11](#) of 20

What was the total number of subscriptions for Newsmagazine x during the year in which Newsmagazine x accounted for 14.6 percent of nationwide news magazine subscriptions?

- 1,020
- 1,980
- 6,300
- 7,000

7,200

[12](#) of 20

In which of the following years did subscriptions to Newsmagazine z account for approximately $\frac{1}{6}$ of the total nationwide magazine subscriptions?

2009

2006

2003

2000

1997

[13](#) of 20

What was the approximate percent increase in nationwide subscriptions to newsmagazines between 1995 and 1996 ?

- 4%
- 11%
- 26%
- 51%
- 73%

[14](#) of 20

In 1998, what was the approximate number of subscriptions to newsmagazines nationwide?

- 3,000
- 13,000

- 16,000
- 20,000
- 67,000

[15](#) of 20

If $a = (27)(3^{-2})$ and $x = (6)(3^{-1})$, then which of the following is equivalent to $(12)(3^{-x}) \times (15)(2^{-a})$?

- $5(-2245)(320)$
- $\frac{2}{5}$
- $\frac{5}{2}$
- $5(24)(38)$
- $5(2245)(320)$

[16](#) of 20

Jill has received 8 of her 12 evaluation scores. So far, Jill's average (arithmetic mean) is 3.75 out of a possible 5. If Jill needs an average of 4.0 points to get a promotion, which list of scores will allow Jill to receive her promotion?

Indicate all such sets.

- 3.0, 3.5, 4.75, 4.75
- 3.5, 4.75, 4.75, 5.0
- 3.25, 4.5, 4.75, 5.0
- 3.75, 4.5, 4.75, 5.0

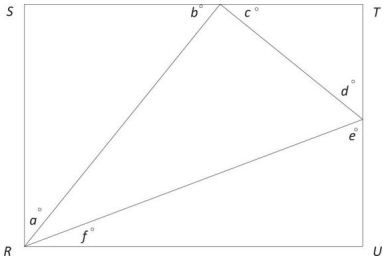

In the figure above, if $RSTU$ is a rectangle, what is the value of $a + b + c + d + e + f$?

degrees

Click on the answer box and type in a number.

Backspace to erase.

If the probability of choosing 2 red marbles without replacement from a bag of only red and blue marbles is $\frac{3}{55}$ and there are 3 red marbles in the bag, what is the total number of marbles in the bag?

- 10
- 11
- 55
- 110
- 165

All first-year students at Red State University must take calculus, English composition, or both. If half of the 2,400 first-year students at Red State University take calculus and half do not, and one-third of those who take calculus also take English composition, how many students take English composition?

- 400
- 800
- 1,200
- 1,600
- 2,000

If $\frac{13!}{2^x}$ is an integer, which of the following represents all possible values of x ?

- $0 \leq x \leq 10$
- $0 < x < 9$
- $0 \leq x < 10$
- $1 \leq x \leq 10$
- $1 < x < 10$

SECTION 4: VERBAL REASONING

For questions 1 through 6, select one entry for each blank from the corresponding column of choices. Fill all blanks in the way that best completes the text.

1 of 20

Since a large amount of the ore frequently located in riverbeds is (i) _____ on the earth's surface, where the processing of chemicals is less costly, recovery of underwater ore is not likely to become a (ii) _____ procedure.

Blank (i)

scanty
abundant
preserved

Blank (ii)

valuable
inexpensive
rejected

2 of 20

It would be (i) _____ for our leaders, given their responsibilities as democratically elected officials, to neglect to do everything they could to (ii) _____ an entirely (iii) _____ problem.

Blank (i)

irresponsible
necessary
frivolous

Blank (ii)

forestall
sustain
cultivate

Blank (iii)

benign
unimportant
avoidable

3 of 20

Despite her mentor's advice that she attempt to sound consistently

_____, the graduate student often resorted to using slang when presenting significant parts of her thesis, her habitual speech patterns overriding her years of learning.

lucid
didactic
panegyric
erudite
rational

[4](#) of 20

Although she felt Steve

(i) _____ the subtlety of the delicious stew recipe with his addition of the sweet potato, she thought the pungent onion (ii) _____ the otherwise (iii) _____ taste combination.

Blank (i)

depleted
permeated
augmented

Blank (ii)

exaggerated
overwhelmed
satiated

Blank (iii)

delicate
zesty
detestable

5 of 20

At first, a still-life painting can appear quite (i) _____, its focus on such everyday objects as flowers or fruits apparently uninspired. In the hands of (ii) _____ painter, however, careful attention to slight shifts of color and texture can lead to a truly (iii) _____ and exemplary painting.

Blank (i)

vital
luxuriant
banal

Blank (ii)

a gauche
an adept
an ascetic

Blank (iii)

unstinting
sublime
prosaic

6 of 20

The leaders of Ukraine's "Orange Revolution" were a study in contrasts. At the center of the political storm stood Viktor Yushchenko, his once (i) _____ face transformed into a monstrous mask by dioxin poisoning; but, at his side, no one could miss the (ii) _____ Yulia Tymoshenko, soon to become the world's only prime minister to adorn the covers of fashion magazines.

Blank (i)

quiescent
fatuous
comely

Blank (ii)

prepossessing
decorous
felicitous

For each of Questions 7 to 11, select one answer choice unless otherwise instructed.

Questions 7 through 9 are based on the following reading passage.

In analyzing the poetry of Mona Feather, we are confronted with three different yardsticks by which to measure her work. We could consider her poems as the product of a twentieth-century artist in the tradition of James Joyce, T.S. Eliot, and Wallace Stevens. However, to do so would be to ignore a facet that informs every word she writes and that stems from her identity as a woman. Yet, to characterize her solely as a woman poet is to deny her cultural heritage, for Mona Feather is also

the first modern poet of stature who is also an American Indian.

Stanley Wilson has argued compellingly that the huge popularity Feather enjoys among the Indian reservation school population of the United States is creating a whole new generation of poetry enthusiasts in an age when the reading of poetry is on the wane. While this is undoubtedly true, Mr. Wilson's praise gives the impression that Feather's readership is limited to her own culture—an impression which hints that Mr. Wilson is himself measuring her by only one criterion. Radical feminist writers have long found in Feather's poetry a sense of self-pride which strikes a chord with their own more political philosophies. Her imagery, which always made use of the

early Native American traditions in which the woman had an important role, was seen as the awakened sensibility of a kindred spirit.

Yet for all the “feminist” touches in her writing, it would be a disservice to consign Feather to the ranks of politicized writers, for her message is deeper than that. The despair that characterized twentieth-century modern poets is to be found in Mona Feather’s work as well; she writes of the American Indians of the 1930s confined to ever-shrinking reservations and finds in that a metaphor for all of modern mankind trapped on a shrinking earth of limited resources.

The primary purpose of the passage is to

- describe the work of Mona Feather
- compare Feather with Joyce, Eliot, and Stevens
- show Feather's roots in her Native American heritage
- argue that Mona Feather's work can be looked at in several different ways
- discuss the women's movement in America

[8](#) of 20

The passage implies that the author believes Stanley Wilson's view of Feather is

- a compelling and complete assessment of her work
- focused too much on her status as a Native American poet
- meant to disguise his opinion of Feather as a poet lacking in talent
- critical of Native American children's literary judgment
- based on all major themes and images in her poetry

[9](#) of 20

The author mentions James Joyce, T.S. Eliot, and Wallace Stevens in order to

- compare the political messages in Feather's work to those in the work of other authors

- highlight the radical differences between male and female poets in the twentieth century
- contrast Feather's thematic choices with those of her contemporaries
- enumerate a list of artists whose sensibilities made them Feather's kindred spirits
- describe a critical context in which Feather's work can be analyzed

Questions 10 through 11 are based on the following reading passage.

Among the more interesting elements of etymology is the attempt to derive the meaning of seemingly nonsensical expressions. Take, for instance, the increasingly archaic rural phrase “to buy a pig in a poke.” For centuries, the expression has been used to signify the purchase of an item without full knowledge of its condition. It relates to the common Renaissance practice of securing suckling pigs for transport to market in a poke, or drawstring bag. Unscrupulous sellers would sometimes attempt to dupe purchasers by replacing the suckling pig with a cat, considered worthless at market. An unsuspecting or naïve buyer might fail

to confirm the bag’s contents; a more **urbane** buyer, though, would be sure to check and—should the seller be dishonest—“let the cat out of the bag.”

[10](#) of 20

Consider each of the choices separately and select all that apply.

Which of the following phrases from the passage would help the reader infer the meaning of the word **urbane** as used in context?

- “increasingly archaic rural phrase”
- “without full knowledge”
- “unsuspecting or naïve buyer”

[11](#) of 20

Select the sentence in which the author provides a definition for an antiquated term that may be unfamiliar to the reader.

For questions 12 through 15, select the two answer choices that, when used to complete the sentence, fit the meaning of the sentence as a whole and produce completed sentences that are alike in meaning.

12 of 20

Although she was such a bad-mannered child that she was sent to a boarding school, as an adult she is the very model of _____.

- friendliness
- diffidence
- propriety
- reticence

decorum

brashness

[13](#) of 20

Politicians sometimes appear to act in a manner that is almost _____; however, when all the information is released after the fact, it is apparent that they were acting according to a deliberate plan.

pithy

conventional

conformist

whimsical

flawless

capricious

14 of 20

Forced to take an alternate road when a massive oil spill closed the highway, the two-hour detour made their already arduous trip even more _____.

- irksome
- onerous
- facile
- glib
- implacable
- immutable

15 of 20

Though many of her contemporaries found her odd, Ella Wilkins is now much admired for her _____ spirit, especially her willingness to

reject prevailing feminine roles and
to travel to foreign lands alone.

- forlorn
- magnanimous
- adventurous
- bellicose
- desolate
- doughty

For each of Questions 16 to 20, select one answer choice unless otherwise instructed.

16 of 20

Microfiber synthetics have been taking the place of natural fibers in an ever-increasing number of clothes because they provide the same durability and deplete fewer natural resources. A shirt made of microfiber synthetics is, however, three times as expensive to produce as a natural-fiber shirt. It follows that the substitution of microfiber synthetic clothes for natural-fiber clothes is, at this time, not recommended from a financial standpoint.

Which of the following statements, if true, most seriously weakens the argument?

- A microfiber synthetic shirt costs one-half the price of a natural-fiber shirt to maintain.
- The production of microfiber synthetic clothes necessitates garment factories to renovate obsolete machinery and to hire extra workers to operate the new machines.
- The upkeep of natural-fiber shirts is far less expensive than the upkeep of any other natural-fiber garment in current production.
- While producers anticipate that the cost of microfiber synthetics will remain stable, they

recognize that the advent of recycling programs for natural fibers should bring down the costs of natural fibers.

- The cost of providing stain guards for microfiber synthetic shirts would probably be greater than what garment producers now spend on stain guards for natural-fiber shirts.

Questions 17 through 18 are based on the following reading passage.

Scholars of early Buddhist art agree that Buddha images in human form emerged around the first century A.D. in the regions of Mathura, located in central India, and Gandhara, now part of Pakistan and Afghanistan. Uncertainty exists, however, about whether Mathura or Gandhara has the stronger claim to primacy. Those who believe that anthropomorphic sculptures of the Buddha first appeared in Gandhara point out that earlier Buddhist art was largely aniconic and that *bas relief* was far more common than sculpture. They argue that Greek influence in Gandhara promoted the development of the new style and form of

representation of the divine. Other scholars make the case for indigenous development of such representations in Mathura, citing a centuries-long record of iconic art in pre-Buddhist traditions. They do not reject all foreign influence, but they argue that local traditions provided a strong foundation for the development of Buddhist sculpture.

Art historians bolster their arguments by highlighting distinctive features of the sculptures from each region. For example, the artists of Gandhara sculpted their Buddhas in heavy, pleated drapery, similar to that of Greek statues. Wavy lines indicating hair also reflect Greek influence. Mathura Buddhas, on the other hand, are portrayed wearing lighter robes draped in a monastic style,

often with part of the shoulder and chest left bare. Elongated earlobes and strong facial features characterize Mathura images of the Buddha, whereas Gandhara images possess more angular features. Sorting out dates and directions of influence has proven difficult, but the totality of evidence suggests that the Buddha image evolved simultaneously in both regions and was shaped by the predominant cultural influences in each region.

[17](#) of 20

Which of the following, if true, would those who believe that anthropomorphic images of Buddha originated in Gandhara be likely to cite as evidence for their viewpoint?

- Pre-Buddhist subcultures in the Gandhara region created representations of their deities in human form.
- Mathuran Buddhas' lightweight robes appear to have been modeled on the real robes of people who lived in a warm climate.
- Gandharan artists were isolated from the larger society and not exposed to influences from outside the region.
- Rulers from the Mathura region had political ties to Greek rulers and frequently exchanged gifts with them.
- The hairstyles worn by Gandharan Buddhas are similar to

those depicted on Greek pottery from the same period.

18 of 20

According to the passage, Buddhist art

- first appeared in regions that are now part of India, Pakistan, and Afghanistan
- experienced a period during which human representations of the Buddha were not common
- characteristically portrayed figures with elongated earlobes and strong facial features
- began to appear in the medium of *bas relief* as a result of Greek influence

- was more influenced by foreign artworks than by indigenous artistic traditions

Questions 19 through 20 are based on the following reading passage.

In 1887, Eugene Dubois began his search in Sumatra for the “missing link”—the being that would fill the evolutionary gap between ape and man. He discovered a fossilized human-like thighbone and a section of skull. He confirmed that these fossils were of significant age by examining other fossils in the same area. The thighbone’s shape indicated that it belonged to a creature that walked upright. Dubois estimated the size of the creature’s skull from the skull fragment and concluded that this creature’s brain volume was between that of the higher primates and that of current humans. Although the concept of

“missing link” has changed dramatically and a recent analysis showed Dubois’s fossils to be far too recent for humans to have evolved from this “missing link,” the value of his discovery and the debate it generated is unquestionable.

[19](#) of 20

Consider each of the choices separately and select all that apply.

The passage supplies information to answer which of the following questions?

- What was the approximate age of the fossils found by Dubois?
- Does Dubois’s find meet current definitions of the “missing link”?

- Do the flaws in Dubois's conclusions invalidate his work?

[20](#) of 20

Select a sentence in which the author reaches a conclusion.

SECTION 5: QUANTITATIVE REASONING

For each of Questions 1 to 7, compare Quantity A and Quantity B, using additional information centered above the two quantities if such information is given. Select one of the following four answer choices and fill in the corresponding circle to the right of the question.

1 of 20

The circle with center R has a radius of 6 and is inscribed inside square $ABCD$

Quantity A

Quantity B

The area of the largest triangle that can be drawn inside square

The area of the circle with center R

$ABCD$

- Quantity A is greater.
- Quantity B is greater.
- The two quantities are equal.
- The relationship cannot be determined from the information given.

2 of 20

$$xy \neq 0$$

$$\frac{a}{xs} = 632 \text{ and } \frac{a}{ys} = 158$$

Quantity A

Quantity B

x y

- Quantity A is greater.
- Quantity B is greater.
- The two quantities are equal.
- The relationship cannot be determined from the information given.

3 of 20

Quantity A

The remainder when 135 is divided by 7

Quantity B

The remainder when 135 is divided by 19

- Quantity A is greater.
- Quantity B is greater.
- The two quantities are equal.

- The relationship cannot be determined from the information given.

4 of 20

a and b are integers.

$$a^2 = b^3$$

Quantity A

Quantity B

a

b

- Quantity A is greater.
- Quantity B is greater.
- The two quantities are equal.
- The relationship cannot be determined from the information given.

5 of 20

$$ab < 0$$

$$bc > 0$$

Quantity A

$$ac$$

Quantity B

$$0$$

- Quantity A is greater.
- Quantity B is greater.
- The two quantities are equal.
- The relationship cannot be determined from the information given.

[6](#) of 20

$$|x| = 6$$

$$y = x + 4$$

Quantity A

$$y$$

Quantity B

$$10$$

- Quantity A is greater.
- Quantity B is greater.
- The two quantities are equal.
- The relationship cannot be determined from the information given.

7 of 20

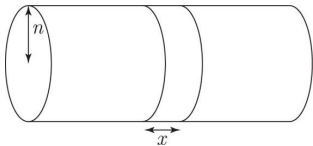

A rectangular ribbon of width x is wrapped around the right circular cylinder with radius n shown above, encircling the cylinder without overlap. The area of the ribbon is equal to the area of the base of the cylinder.

Quantity A

Quantity B

x

n

- Quantity A is greater.
- Quantity B is greater.
- The two quantities are equal.
- The relationship cannot be determined from the information given.

[8](#) of 20

List A : 1, 2, 7, 8, 15, 2, 3, 5, 6, 13

x is the median of the even numbers in List A .

y is the median of the prime numbers in List A .

z is the median of the least and greatest numbers in List A .

Quantity A**Quantity B**

The median of
 $2x$, y , and z

z

- Quantity A is greater.
- Quantity B is greater.
- The two quantities are equal.
- The relationship cannot be determined from the information given.

9 of 20

Oil is pumped from a well at a rate of 500 gallons per hour. How many gallons of oil are pumped from the well in 3 hours and 15 minutes?

gallons

Click on the answer box and type in a number.

Backspace to erase.

10 of 20

A certain pet store sells only dogs and cats. In March, the store sold twice as many dogs as cats. In April, the store sold twice the number of dogs that it sold in March, and three times the number of cats that it sold in March. If the total number of pets the store sold in March and April combined was 500, how many dogs did the store sell in March?

- 80
- 100
- 120
- 160

11 of 20

In the coordinate plane, rectangle $WXYZ$ has vertices at $(-2, -1)$, $(-2, y)$, $(4, y)$, and $(4, -1)$. If the area of $WXYZ$ is 18, what is the length of its diagonal?

○ $3\sqrt{2}$

○ $3\sqrt{3}$

○ $3\sqrt{5}$

○ $3\sqrt{6}$

○ $3\sqrt{7}$

12 of 20

How many three-digit integers can be created from 5 distinct digits?

- 10
- 15
- 20
- 30
- 60

[13](#) of 20

At Megalomania Industries, factory workers were paid \$20 per hour in 1990 and \$10 per hour in 2000. The CEO of Megalomania Industries was paid \$5 million per year in 1990 and \$50 million per year in 2000. The percent increase in the pay of Megalomania's CEO from 1990 to 2000 was what percent greater than the percent decrease in the hourly pay of

Megalomania's factory workers over the same period?

- 850%
- 900%
- 950%
- 1,700%
- 1,900%

Questions 14 through 16 refer to the following graph.

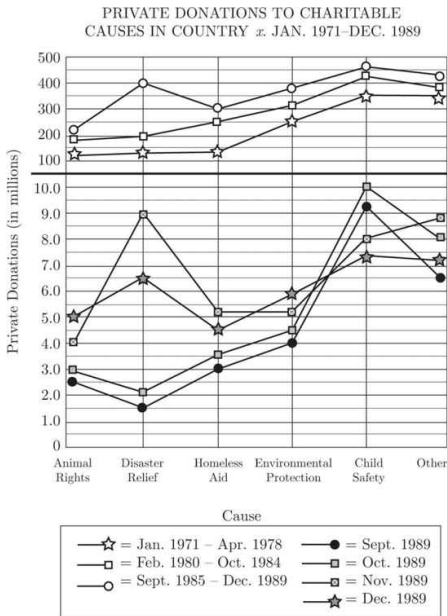

[14](#) of 20

If there were 38 child safety organizations and the funds contributed to these organizations in September 1989 were evenly distributed, how much did each charity receive?

- \$12,000,000
- \$9,400,000
- \$2,500,000
- \$250,000
- \$38,000

[15](#) of 20

From September 1985 to December 1989, what was the approximate ratio of private donations in millions for homeless aid to private donations in millions for animal rights?

- 20 : 9
- 3 : 2
- 4 : 3
- 9 : 7
- 6 : 5

[16](#) of 20

Which of the following charitable causes received the smallest percent increase in private donations from September 1989 to October 1989 ?

- Animal Rights
- Disaster Relief
- Homeless Aid
- Environmental Protection
- Child Safety

17 of 20

In the repeating decimal $0.0653906539\dots$, the 34th digit to the right of the decimal point is

- 9
- 6
- 5
- 3
- 0

18 of 20

If $3x + 2y = 24$, and $\frac{7y}{2x} = 7$, then $y =$

Click on each box and type in a number.

Backspace to erase.

[19](#) of 20

If the average (arithmetic mean) of 6, 8, 10, and x is between 6 and 12, what is the greatest possible integer value of x ?

- 8
- 11
- 20
- 28
- 44

[20](#) of 20

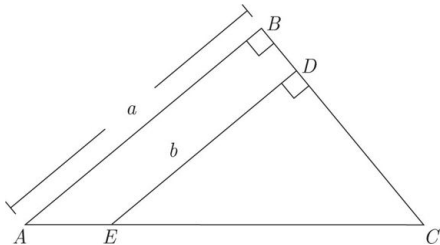

If $AB = BC$, which of the following is an expression for the area of quadrilateral $ABDE$?

- $\frac{a^2}{2} - \frac{b^2}{2}$
 $\frac{a^2}{2} + \frac{b^2}{2}$
 $a^2 - b^2$
 $\frac{a^2}{4} - \frac{ab}{2}$
 $\frac{a^2}{4} + \frac{ab}{2}$

SECTION 6: VERBAL REASONING

For questions 1 through 6, select one entry for each blank from the corresponding column of choices. Fill all blanks in the way that best completes the text.

1 of 20

Many fashions that were considered daring in their time have been so widely worn and imitated that the (i) _____ style is no longer seen as (ii) _____.

Blank (i)

proposed
original
revealing

Blank (ii)

outlandish
commonplace
copied

2 of 20

Western culture has so influenced Middle Eastern music that even the latter's roles of composer and performer, at one time inseparable, have now begun to _____.

divulge
retreat
retrench
diverge
fuse

3 of 20

Kazan was quickly (i) _____
by many of his contemporaries for

his transgression, who saw his testimony as treachery, an act of (ii) _____ which stained how they viewed him both as an artist and as a man. It was only by continually making films that he was able to (iii) _____ his perceived sins and achieve some measure of atonement.

Blank (i)

rebuked
lauded
mitigated

Blank (ii)

perfidy
sophistry
redemption

Blank (iii)

exacerbate
deviate
expiate

[4](#) of 20

Although tranquilizers usually have a _____ effect, this is not always the case, especially when the abuse of these drugs results in a failure to induce the much-desired sleep.

soporific
sedulous
coruscating
debilitating
penetrating

5 of 20

As a rule, (i)_____ interpretations of events are rejected by modern scientists in their attempts to find secular insights into the matrix of causes and effects in our modern world. Paradoxically, this fact does not (ii)_____ the existence of individual scientists who possess views that may be (iii)_____ with a belief in supernatural causes.

Blank (i)

falsifiable
preternatural
teleological

Blank (ii)

countenance
enhance
preclude

Blank (iii)

at variance
consonant
discrepant

6 of 20

The Johnsons were not known for their (i)_____; at the very least, none of the family members was fearful of (ii)_____, of appearing or acting differently from other people.

Blank (i)

candor
vulgarity
conformity

Blank (ii)

pettiness
eccentricity
complaisance

For each of Questions 7 to 12, select one answer choice unless otherwise instructed.

Questions 7 through 10 are based on the following reading passage.

According to most scientists, the universe began approximately 10 to 15 billion years ago and has been expanding ever since. This theory, known as the Big Bang theory, is the fairly direct result of Hubble's law, which states that objects farther away from Earth are receding faster than those closer. This expansion implies a singular point which all matter is expanding from.

Complicating the scientific explanation is that the Big Bang cannot be thought of as an explosion from

some identifiable source—rather, space and time were created in the Big Bang. Furthermore, the relationship between distance and speed is not precisely linear. So, if one were to think of galaxies as particles created in a big bang, these galaxies have both a local component of motion, as well as playing a role in the overall expansion of the universe.

A further complication is that galactic distances are so great that galactic motion, even if the galaxies are moving at incredible speeds, is difficult to observe. Scientists must therefore rely on a “standard candle,” an object of known brightness within the galaxy they wish to observe. Using the inverse square law, scientists can then measure how far that galaxy is away from our

own. For instance, suppose a supernova in galaxy A appears one hundred times as bright as one in galaxy B. By the inverse square law, galaxy B is ten times farther away than galaxy A, assuming, of course, that distance is the only factor affecting brightness.

7 of 20

It can be inferred from the sentence highlighted in the passage that a standard candle is useful to scientists for which of the following reasons?

- Standard candles do not have their own locus of motion.
- Standard candles more reliably adhere to the law of inverse

squares than do other supernovas.

- Only standard candles provide a known measure of brightness.
- Knowledge of an object's brightness allows scientists to measure the speed at which the object is moving toward Earth.
- Knowledge of an object's brightness allows scientists to accurately measure its distance from Earth.

[8](#) of 20

Consider each of the choices separately and select all that apply.

According to the passage, if two astronomical objects of differing distances from Earth were observed,

which of the following would be true of the object closer to Earth?

- It would not be as bright as the object farther from Earth.
- It would be younger than the object farther from Earth.
- It would be traveling away from the Earth more slowly than the farther object.

9 of 20

It can be inferred from the passage that a standard candle may not provide an accurate measure of distance if

- the galaxy being measured is moving too quickly

- interstellar dust makes the object measured appear dimmer than it really is
- if the galaxy being measured has a local component of measurement
- the particles being measured do not completely accord with a linear motion
- the galaxies being measured move at different speeds

[10](#) of 20

According to the passage, if two supernovas are observed and one of those supernovas is brighter than the other, scientists can conclude that

- the brighter supernova is moving closer to our galaxy at a higher speed
- the precise location of the supernova is measurable
- the brighter supernova may be closer to our own galaxy
- the brighter supernova is farther away from Earth by a distance that is roughly inversely proportional to the dim supernova
- the distance between the supernovas and our own galaxy is inversely proportional

Questions 11 through 12 are based on the following reading passage.

Throughout the twentieth century, it was accepted as fact that cells in our

brains, called neurons, do not regenerate. Research by neurologist Elizabeth Gould overturned this core doctrine within the span of a few years. Her experiments on rats showed that even after suffering severe trauma, their brains were able to heal themselves by regenerating neurons. Gould's findings have incited a flood of new research into applications that may take advantage of neurogenesis.

One such study examines the role of reduced neurogenesis among individuals suffering from depression. It is speculated that neurogenesis may contribute to an explanation for the so called "Prozac lag." As an antidepressant, the immediate boost of serotonin caused by Prozac should have had instantaneous mood elevating effects. However, patients

suffering from depression only begin to experience mood elevation weeks after beginning treatment. The study speculates that during this period, the brain may be regenerating neurons.

[11](#) of 20

The author mentions the “Prozac lag” primarily in order to

- raise a possible objection to a newly proposed theory
- present a situation for which a new theory may serve an explanatory role
- offer evidence that runs counter to a previously held belief
- suggest a counterexample that undermines a newly proposed theory

- 1401/1807
- provide supporting evidence that a newly discovered phenomenon may have unforeseen effects

[12](#) of 20

In the second paragraph, select the sentence in which the author describes an unexpected observation.

For questions 13 through 16, select the two answer choices that, when used to complete the sentence, fit the meaning of the sentence as a whole and produce completed sentences that are alike in meaning.

13 of 20

Plato, an important philosopher, is primarily known because he wrote down Socrates's _____ conversations. It is through Plato's record of these dialogues that Socrates's teachings have survived and continue to enlighten seekers of wisdom.

inspiring

- edifying
- tedious
- grating
- rousing
- didactic

[14](#) of 20

Even the colossal meal failed to _____ her voracious appetite.

- cadge
- exacerbate
- provoke
- satiate
- mendicant
- allay

[15](#) of 20

Slicks of oil on a rain-soaked street are _____ and beautiful, but the lovely rainbows they produce on the asphalt can seem rather ugly when one reflects upon the road hazards they create and the environmental damage they entail.

- anodyne
- iridescent
- monocoque
- pavonine
- parietal
- saturnine

[16](#) of 20

He had not always been so callous, but with time he became

_____ to the violence
around him.

- adorned
- cauterized
- sensitized
- ostracized
- inured
- attuned

For each of Questions 17 to 20, select one answer choice unless otherwise instructed.

[17](#) of 20

When the maker of Megapower, a vitamin supplement, modified its formula two years ago, Tasmania, an island off the coast of New Zealand, suffered a decrease in its export earnings. Tasmania's only export, kiwi fruit, constitutes a substantial portion of the world supply of that fruit. Researchers concluded that the old Megapower formula contained natural kiwi extract, but the new formula does not.

Which of the following, if true, gives the strongest support for the researchers' claim?

- Some South American countries have begun to grow kiwi fruit successfully.
- United States chemists have started development of a synthetic kiwi extract.
- The manufacturers of Mega-power chose not to renew their contract with the Tasmanian kiwi growers.
- Imports of kiwi fruit have fallen in the country where Mega-power is manufactured.
- There was a marked drop in sales of a number of formerly profitable items that used kiwi as an ingredient.

Questions 18 through 20 are based on the following reading passage.

While art historians do not necessarily agree on the date of the birth of modern art, they do agree that mid-nineteenth century French art shows a clear and distinct break from tradition. Pressed to point to a single picture that represents the vanguard of the modern art movement, art historians will often point to Courbet's *The Painter's Studio*.

The peculiar subtitle of Courbet's work, "Real allegory summing up a seven-year period of my life" confirms that Courbet was striving to do something strikingly original with his work. The argument has been made that the painting

struck a blow for the independence of the artist, and that since Courbet's work, artists have felt freed from the societal demands placed upon their work. Paintings prior to Courbet's time were most often focused on depicting events from the Bible, history, or literature. With his singular painting, Courbet promulgated the idea that an artist is capable of representing only that which he can experience through his senses of sight and touch; the true artist will then be compelled to make his representation as simply and directly as possible.

18 of 20

Which of the following would most effectively replace the word

promulgated as it is used in the context of the passage?

- Displayed
- Disseminated
- Proclaimed
- Concealed
- Secreted

[19](#) of 20

Select the sentence in the passage that best explains the effect of Courbet's work on other artists.

[20](#) of 20

The effect that Courbet had on painting is most analogous to which situation?

- An avant-garde writer who subverts novelistic conventions
- A machinist who tinkers and improves his invention
- A watercolor painter who paints in the same style as his peers
- A scientist who comes up with a unified theory of several discordant scientific ideas
- A seamstress who makes a ball gown using several different types of fabric

Chapter 18

Answers

Explanations

Practice Test 1

and

for

INTERPRETING YOUR RESULTS

After you check your answers on the following pages, fill out this sheet to interpret your results.

Analytical Writing

To evaluate your performance on the Analytical Writing sections, compare your response to the advice and samples in the Analytical Writing chapter.

Verbal Reasoning

Refer to the explanations to check your answers. Count the number of questions you got correct in each Verbal Reasoning section, and calculate the total number correct. Find

the section of the Interpretive Guide (below) that corresponds to your total to get an idea of how your performance compares to that of other test takers.

Test 1	# Correct
Section 4	
Section 6	
Total	

Quantitative Reasoning

Refer to the explanations to check your answers. Count the number of questions you got correct in each Quantitative Reasoning section, and calculate the total number correct. Find the section of the Interpretive

Guide (below) that corresponds to your total to get an idea of how your performance compares to that of other test takers.

Test 1	# Correct
Section 3	
Section 5	
Total	

Interpretive Guide

The table below provides a guide for interpreting your performance based on the number of questions you got correct in each subject.

Subject	Above Average	Average	Below Average
Verbal Reasoning	30–40	22–29	1–21
Quantitative Reasoning	33–40	24–32	1–23

Section 3

1. A

Point C has the same x -coordinate as point D , so $s = 8$. Point C also has the same y -coordinate as point B , so $t = 7$. That means that Quantity A is greater.

2. A

The punch is made with two parts soda and three parts ice cream. This means that in one mixture if you added two parts of soda, then that's $4 \times 2 = 8$ parts sugar and $5 \times 2 = 10$ parts citric acid. If you added three parts ice

cream, then that's $3 \times 3 = 9$ parts sugar and $2 \times 3 = 6$ parts salt. There's $8 + 9 = 17$ total parts sugar and $10 + 6 = 16$ total parts citric acid. There's more sugar than citric acid.

3. B

If you Plug In 5 for x , the total for the 5 days already in the set is 350; after adding the additional 75 degree temperature, the new total is 425, and the new average is $\frac{425}{6}$, which reduces to $70\frac{5}{6}$, which is less than 71 degrees.

This means that x cannot equal 5 and thus we can eliminate choice (C). If $x =$

4, then the total for the 4 days would be 280; after adding 75, the new total would be 355, and the new average would be $\frac{355}{5}$, which reduces to 71.

Thus we can eliminate choice (A). The answer is choice (B).

4. D

Because $\triangle QRS$ is isosceles, side RS must be equal to one of the other sides, and x could measure 4 or 7. Thus, the perimeter could be $4 + 4 + 7 = 15$, or the perimeter could be $4 + 7 + 7 = 18$. You can't tell if the perimeter is greater or less than 17, and, thus, the answer is choice (D). Remember: If it

doesn't say "Drawn to scale," you can't assume it is!

5. B

Remember that a normal distribution curve has divisions of 34 percent, 14 percent, and 2 percent on each side of the mean. 80 out of 500 is 16 percent, or 14 percent + 2 percent, and 10 out of 500 is 2 percent. Draw a normal distribution curve and label it. There are three standard deviations between 92 and 56, so $92 - 56 = 36$, and $36 \div 3 = 12$. The mean is $92 - 12 = 80$, which is smaller than Quantity B.

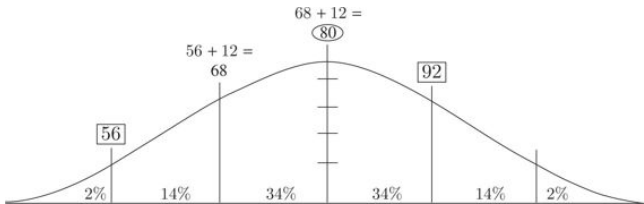

6. C

Plug In numbers for the sides. Let $AD = 4$, so $EG = 8$. Let $l = 3$. The area of $ABCD = 3 \times 4 = 12$, and the area of $EFG = \frac{1}{2}(3 \times 8) = 12$. The two quantities can be equal, so eliminate answer choices (A) and (B). Try changing your numbers, and you will see that the two quantities will always be equal.

7. B

FOIL out the equation given, and you'll get $(3x - 4y)(3x + 4y) = 9x^2 - 16y^2$, so Quantity A is 2. Quantity B is

therefore bigger, and the answer is (B).

8. C

Solve for a by adding 2 to each side to get $8a = 24$. Divide by 8 to find $a = 3$. Plug $a = 3$ into the second equation to find $4(3) - 1 = 12 - 1 = 11$. Alternatively, you could save yourself some time by noticing that $8a - 2$ is $2(4a - 1)$. If $2(4a - 1) = 22$, divide by 2 to get $4a - 1 = 11$.

9. 56

Twenty percent of the sweaters in the store are white, so there are $200 \times \frac{20}{100} = 40$ white sweaters. There are $200 - 40 = 160$ sweaters remaining. Of the

remaining sweaters, $160 \times \frac{40}{100} = 64$
are brown. That means that $160 - 64$
 $= 96$ are blue. There are $96 - 40 = 56$
more blue sweaters than white
sweaters.

10. D

Because 4^{12} is a common factor of
both 4^{13} and 4^{12} , you can rewrite the
numerator as $4^{12}(4 - 1)$. Now look at
the whole fraction: $\frac{4^{12}(4 - 1)}{4^{11}}$. You can
divide 4^{12} by 4^{11} , leaving you with $4^1(4$

– 1). Now the calculation should be much easier. $4 \times 3 = 12$, choice (D).

11. **D**

Refer to the right side and the left side of the “Subscription to Newsmagazine x , 1995-2010” chart. In 2005, Newsmagazine x accounted for 14.6 percent of newsmagazine subscriptions, and it had 7,000 subscriptions.

12. **B**

In 2006, Newsmagazine z accounted for 9,400 out of 57,000 newsmagazine subscriptions. Therefore, Newsmagazine z accounted for

approximately 9,000 out of 57,000, or $\frac{1}{6}$, of the nationwide newsmagazine subscriptions.

13. D

In 1995, there were 1,500 subscriptions to Newsmagazine x , which accounted for approximately 25 percent of total nationwide subscriptions. Total nationwide subscriptions in 1995, then, were equal to about 6,000 (25 percent of total nationwide subscriptions = 1,500). Using the same

process, total nationwide subscriptions in 1996 were equal to about 9,000 (30 percent of total nationwide subscriptions = 2,600). The percent increase between 1995 and 1996 is

$$\frac{\text{difference}}{\text{original}} = \frac{9,000 - 6,000}{6,000} = \frac{3,000}{6,000} = \frac{1}{2}, \quad \text{or } 50 \text{ percent.}$$

14. C

In 1998, Newsmagazine x had 3,300 subscriptions, or 20.5 percent of the total number of newsmagazine

subscriptions. Set up the calculation to find the total: $3,300 = \frac{205x}{100}$. Solve it to find that $x = 16,000$.

15. C

$$a = 27 \times \frac{1}{3^2} = 3, \text{ and } x = 6 \times \frac{1}{3} = 2.$$

$$\text{Find } (12)(3^{-x})(15)(2^{-a}) =$$

$$(12)(3^{-2})(15)(2^{-3}) = \frac{(12)(15)}{(3^2)(2^3)}. \text{ Now,}$$

$$\text{reduce: } \frac{(2 \times 2 \times 3)(3 \times 5)}{(3 \times 3)(2 \times 2 \times 2)} = \frac{5}{2}.$$

16. B and D

Use the Average Pie to find that Jill's mean of 3.75 for 8 evaluations gives her a current total of $3.75 \times 8 = 30$ points. Use the Average Pie to find

that if she needs an average of 4.0 for 12 scores, she needs $4.0 \times 12 = 48$ total points. Jill still needs $48 - 30 = 18$ points. Her four remaining scores must total 18 or greater. Only answers (B) and (D) have a total of at least 18.

17. 270

Your best bet is to plug in values for all the angles, keeping in mind that those inside the triangle must add up to 180° , the ones along BC must add up to 180, the ones along CD must add up to 180° , and the ones at A must add up to 90° . Then add up the marked angles.

18. B

Plug In The Answers starting with choice (C). If the total is 55, then the probability would be $\left(\frac{3}{55}\right)\left(\frac{2}{54}\right)$, which does not equal $\frac{3}{55}$. The denominator is too large, so try choice (B). If the total is 11, then the probability is $\left(\frac{3}{11}\right)\left(\frac{2}{10}\right)$, which reduces to $\frac{3}{55}$.

19. D

Use the Group formula: Total = Group₁ + Group₂ - Both + Neither. In this problem the total is 2,400. The question also states that 1,200 students (half of the total) take calculus, so that is Group₁; one-third of that group (400) take both calculus and

English. Because every student takes calculus or English or both, the Neither group is zero. Solve for the number of students who take English by plugging these numbers into the group formula: $2400 = 1200 + \text{Group}_2 - 400$. The number of students who take English is 1,600, or choice (D).

20. A

To solve this expression you need to break apart the factorial of 13 to the common prime number in the denominator, in this case the number 2. $13!$ can be expressed as $13 \times 12 \times 11 \times 10 \times 9 \times 8 \times 7 \times 6 \times 5 \times 4 \times 3 \times 2 \times 1$. When you break apart this factorial into its prime numbers you are left with $13 \times 11 \times 7 \times 5^2 \times 3^5 \times 2^{10}$. For a fraction to result in an integer, the denominator of the fraction must share at least one

prime factor with the numerator. The greatest number of 2's that can be found in the prime factorization of $13!$ is 10 so $x \leq 10$. Eliminate choices (B), (C), and (E). Now for the tricky part! Any nonzero number raised to the power 0 is 1. Since the result when any integer is divided by 1 is also an integer, 0 must be included in the range of possible x values. The answer is (A).

Section 4

1. **abundant** and **inexpensive**

The clue for the second blank is “on the earth’s surface, where the processing of chemicals is less costly.” Underwater recovery, in contrast, would be more expensive. The second blank describes what’s not true of the procedure, so use a word that means low-cost. *Cost-effective* is a close match. Use the same clue for the first blank. If the processing of ores from the surface is less costly, those ores must be plentiful. *Abundant* is a good match.

2. **irresponsible**, **forestall**, and **avoidable**

The keys to the first blank are the clues “given their responsibilities as democratically elected officials” and “neglect to do everything they could.” These clues indicate that the first blank should have a negative connotation; a word that means something as simple as *bad* would eliminate *thoughtful* and *intuitive*, leaving *irresponsible*. Blanks (ii) and (iii) build on the idea set up in the first half of the sentence. The second blank describes the action that would be bad, so use something that means solve. *Sustain* and *cultivate* are the opposites of what’s needed for the second blank, leaving *forestall*. The last blank describes the type of problem, and entirely suggests it’s a solvable problem. *Avoidable* is close, and it helps the whole sentence make sense.

3. erudite

Despite is a trigger word that implies a contrast between the student's actual behavior when presenting her thesis and her mentor's advice. The student resorted to using slang, language that is informal and unscholarly. Therefore, the word in the blank must mean *formal* or *scholarly*. The only word that fits that description is *erudite*, which is the best choice. The other answer choices can be used to describe speech, but none of these words contrast the mentor's advice with the student's use of slang.

4. augmented, overwhelmed, and delicate

Start with the second blank. The clue *pungent* tells you this onion did something bad to the delicious stew.

Exaggerated and *satiated* are positive; *overwhelmed* is the only fit. The trigger *otherwise* tells you to change direction from the third blank's clue of *pungent*. Look for a word that means *subtle* or *soft*. Only *delicate* fits. For the first blank, the clue is that Steve's stinky onion hurt the delicate stew. The trigger *although* tells you to change direction. So, this addition of the sweet potato was good. Only *augmented* fits.

5. **banal, an adept, and sublime**

The first clue is *its focus on such everyday objects as flowers or fruits apparently uninspired*, so the first blank has to mean something such as “uninspired.” *Banal*, which means predictable, matches this. For the second blank, the painter must pay *careful attention*, so the second blank

must mean “careful” or “talented,” which matches *an adept*. Since the painting is *exemplary*, the third blank must be *sublime*.

6. **comely** and **prepossessing**

The first blank describes Viktor Yuschenko’s face. The clue is that his face was *transformed into a monstrous mask by dioxin poisoning* and the trigger word *once* tells us an appropriate word for the blank would be the opposite of monstrous; something like attractive would work nicely. *Quiescent* means calm, and *fatuous* means foolish, so those words don’t work. *Comely*, which means attractive, is the only word that works. The second blank is describing Yulia Tymoshenko. Both the trigger phrase *a study in contrasts* and the clue about *fashion magazines* suggest that a

word that means beautiful is appropriate. Though it might not sound like it, *prepossessing* does, in fact, mean beautiful. *Felicitous* means well-expressed, and *decorous* means full of propriety, so although they are both positive words, they aren't as fitting here as the credited response is.

7. D

According to the first sentence, her work can be viewed three different ways. The rest of the passage describes those ways: as the work of a modern poet, of a woman, and of a Native American. Choice (A) is too vague, and the passage doesn't so much describe her work as how it should be viewed. Choices (B) and (C) are too narrow and don't describe the overall purpose. Choice (E) doesn't match the passage.

8. B

In the second paragraph the author states, “Mr. Wilson’s praise gives the impression that Feather’s readership is limited to her own culture—an impression which hints that Mr. Wilson is himself measuring her by only one criterion,” which best fits choice (B). Choices (A) and (E) contradict the passage and are too broad and extreme. Choice (C) contradicts the passage, and choice (D) is not supported.

9. E

The second sentence of the passage claims, “We could consider her poems as the product of a twentieth-century artist in the tradition of James Joyce, T.S. Eliot, and Wallace Stevens.” Thus, the author mentions Joyce, Eliot, and Stevens in order to describe one

context—twentieth-century poetry—in which Feather’s work can be analyzed. Eliminate choice (A) because the author doesn’t compare Feather’s political messages to those of these authors. Eliminate choice (B) because the author doesn’t use these authors to discuss differences between male and female poets. Eliminate choice (C) because the author doesn’t contrast Feather’s themes with those of these authors. Although Joyce, Eliot, and Stevens were, like Feather, twentieth-century artists, the passage doesn’t say that they shared sensibilities, which eliminates choice (D).

10. C

Only answer choice (C) provides a clue to the meaning of *urbane* as used here: The urbane buyer is contrasted with the “unsuspecting or naïve

buyer,” and so must mean “not unsuspecting” or “not naïve.” Choice (A) tantalizingly dangles the word rural before our eyes, trying to take advantage of that word’s well-known association with the word urban. *Urbane*, though, means *sophisticated*. Moreover, if answer choice (A) were accepted, the strangely illogical proposition that city-dwellers knew best how to buy animals at market would have to be accepted as well. Answer choice (B), thankfully, presents no such difficulties of interpretation and appears in the definition of the obscure expression itself, not in the comparison between unsuspecting and urbane.

11. It relates to the common Renaissance practice of securing

suckling pigs for transport to market in a poke, or drawstring bag

In this sentence the author defines the term “poke” as a drawstring bag. This is the only instance in which the author gives a definition for a word that the reader may not be familiar with because the word “poke” is not a common term used to describe a drawstring bag.

12. propriety and decorum

The clue is “was such a bad-mannered child.” Time acts as a change-of-direction trigger (“now, as an adult”) that indicates the blank should mean something like well-mannered. Only *propriety* and *decorum* mean well-mannered. *Diffidence*, *reticence*, and *brashness* are all traits that would be

1441/1807

considered bad-mannered. *Friendliness* does not necessarily mean well-mannered.

13. **whimsical** and **capricious**

The blank describes how politicians act. The clue is “acting out a deliberate plan.” The change-of-direction trigger *however* tells you that they appear not to have a plan. Words that mean unplanned or random should be in the blank. Both *whimsical* and *capricious* fit this meaning. *Conventional* and *conformist* have the opposite meaning. The other two words are unrelated to the blank.

14. **irksome** and **onerous**

The trigger “even more” tells you to stay in the same direction as the clue. “Forced to take an alternate road,”

“two-hour detour,” and “arduous trip” tell you that the journey was difficult. Put a word that means hard or tiring in the blank. Only *irksome* and *onerous* fit this meaning. *Facile* and *glib* describe something easy, and *implacable* and *immutable* describe something that doesn’t change.

15. **adventurous** and **doughty**

The trigger *especially* tells you to stay in the same direction as the clue “willingness to reject prevailing feminine roles and travel to foreign lands alone.” Thus, she has a bold spirit. Only *adventurous* and *doughty* mean bold. Although she is traveling alone, there is nothing to support that she is lonely, as *forlorn* and *desolate* suggest. *Magnanimous* and *bellicose* do not fit.

16. A

The argument concludes that the substitution of microfiber clothes for those made from natural fabrics is not financially sound. The premise is that microfiber clothes last as long as natural fabric clothes but are three times as expensive to produce. The argument assumes that there are no other factors that need to be considered to evaluate the cost effectiveness of switching. Choice (A) points out another factor that would affect the overall costs and so weakens the argument. Choice (B) helps to explain why the microfiber synthetic shirt is more expensive to produce than a natural fiber shirt, but it does not weaken the argument. In choice (C), comparing natural fiber shirts and other fiber garments is not relevant. Choice (D) strengthens the argument. Choice (E), by pointing

out additional costs associated with microfibers, also strengthens the argument.

17. **E**

The first paragraph presents the Gandhara-first view “... Greek influence in Gandhara promoted the development of the new style and form of representation of the divine.” The second paragraph provides evidence Gandharan Buddhas shared certain features with Greek art. Choice (E) provides additional information about those similarities and is the best choice. Choices (A) and (C) undermine the idea that Gandharan artists were responding to outside influences. Choice (B) is irrelevant, and choice (D) provides evidence for outside influences in Mathura.

18. B

The first sentence says that “images in human form emerged around the first century A.D.,” and the middle of the first paragraph states that “earlier Buddhist art was largely aniconic.” You can conclude from these statements that the earliest Buddhist art didn’t usually depict the Buddha in human form. Eliminate choice (A); although human representations first appeared in these regions, the passage doesn’t say that the first Buddhist art appeared in the same places. The passage doesn’t support choices (C), (D), and (E).

19. B and C

For choice (A), the passage says only that the age of these fossils was “far too recent for humans to have

evolved” from them. This does not give an age for the fossils. The last sentence says that “the concept of ‘missing link’ has changed dramatically,” which answers the question in choice (B). The last sentence also answers the question in choice (C) because it says, “the value of his discovery and the debate it generated is unquestionable.”

- 20.** **Although the concept of “missing link” has changed dramatically and a recent analysis showed Dubois’s fossils to be far too recent for humans to have evolved from this “missing link,” the value of his discovery and the debate it generated is unquestionable.**

In the last sentence, the author states that the value of Dubois’s fossils is

“unquestionable.” This statement represents the author’s conclusion.

Section 5

1. B

Draw the figure. You have a square with a circle inside of it that has a radius of 6. Therefore, the length of one side of the square is 12. Quantity A asks for the area of the largest triangle that can be drawn inside the square. The largest triangle cuts the square in half diagonally (subsequently creating a $45 : 45 : 90$ triangle) and has a

height and base of length 12. So the area of the triangle is $\frac{1}{2}(12)(12) = 72$.

Quantity B is asking for the area of the circle with center R. So the area of the circle is $6^2\pi$, or 36π . π is approximately 3, so you know that 36 times 3 is greater than 72. Quantity B is greater.

2. D

There are a lot of variables in this problem, so starting thinking about Plugging In. The variable a has to be the same for each equation. You cannot pick just any number, however, because you must satisfy the equations. When you feel stuck on a

problem start looking at the numbers; remember the math will always work out nicely. Examining the two equations you realize that $158 \times 4 = 632$, so these two numbers are related. So the easiest number to Plug In for a is 632. Now you know that $xs = 1$, and $ys = 4$. Since the variable s is the same in both equations, they cancel each other out and you are left with $x = 1$ and $y = 4$. Eliminate (A) and (C). Next, try a FROZEN number such as $a = -632$. In this case, $xs = -1$ and $ys = -4$ or $x = -1$ and $y = -4$. Eliminate (A). The correct answer is (D).

3. C

$135 \div 7 = 19$, remainder 2. $135 \div 19 = 7$, remainder 2. Both Quantity A and Quantity B equal 2.

4. D

Plug In. Let $a = 8$ and $b = 4$. Quantity A can be greater than Quantity B, so eliminate answer choices (B) and (C). Now let $a = b = 1$. Quantity A can be equal to Quantity B, so eliminate answer choice (A).

5. B

Plug In numbers for a , b , and c . If $a = -2$, $b = 3$, and $c = 4$, then $ac = -8$. Quantity B is greater; eliminate choices (A) and (C). If $a = 2$, $b = -3$, and $c = -4$, then ac is still negative. Quickly consider different numbers, but realize that Quantity A will always be negative.

6. D

If $|x| = 6$, then $x = 6$, or $x = -6$. If $x = 6$, then $y = 6 + 4 = 10$. The quantities are equal, so you can eliminate choices

(A) and (B). If $x = -6$, then $y = -6 + 4 = -2$, and Quantity B is greater. Eliminate choice (C), and select choice (D).

7. B

Plug In for the radius, n , and solve for x . Let's make $n = 3$: The area of the base of the cylinder is now 9π , and the circumference of the base is 6π . The ribbon itself is a rectangle, and we now know both its area, which is the same as the area of the base, and its length, which is the same as the circumference of the base. Now we can solve for x , which is the other side of the rectangle: $6\pi x = 9\pi$, so $\frac{9\pi}{6\pi}$, or $\frac{3}{2}$. Our value for n is greater than our value for x , so Quantity B is greater.

8. C

Remember that median is the number that ends up in the middle of the list when you rewrite the list in numerical order. Find x : The even numbers are 2, 2, 6, 8. Because 2 and 6 are in the middle, find their mean: $\frac{2+6}{2} = 4$. So, $x = 4$. Find y : The prime numbers are 2, 2, 3, 5, 7, 13. Remember: 1 is not prime. Because 3 and 5 are in the middle, find their mean: $\frac{3+5}{2} = 4$. So, $y = 4$. Find z : The least is 1, and the greatest is 15. The median of 1 and 15 is $\frac{1+15}{2} = 8$. So, $z = 8$. For Quantity A,

find the median of 2(4), 4, and 8: So, the median of 4, 8, 8 is 8. Quantity B is also 8.

9. 1,625

Set up a proportion:

$$\frac{1 \text{ hour}}{500 \text{ gallons}} = \frac{3.25 \text{ hours}}{x \text{ gallons}}$$

Cross multiply to find that $x = 500 \times 3.25 = 1,625$ gallons.

10. B

Plug In the answers, starting with the middle choice. If 120 dogs were sold in March, then 60 cats were sold that month. In April, 240 dogs were sold, along with 180 cats. The total number

of dogs and cats sold during those two months is 600, which is too large, so eliminate choices (C), (D), and (E). Try choice (B). If there were 100 dogs sold in March, then 50 cats were sold; in April, 200 dogs were sold along with 150 cats. The correct answer is (B) because $100 + 50 + 200 + 150 = 500$.

11. C

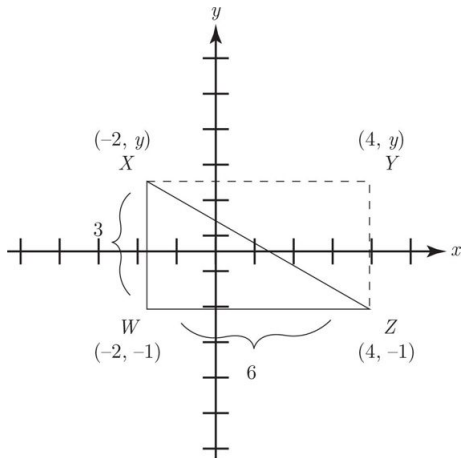

Notice that the length of WZ is $4 - (-2) = 6$. If area is $18 = 6 \times w$, then w is equal to 3. The length, therefore, must be 6. Use this to find the area. $18 = l \times 3$, and the length is 6. Now you have a right triangle with legs of 3 and 6. Use the Pythagorean theorem: $3^2 + 6^2 = c^2$, or $9 + 36 = c^2$. So, $c = \sqrt{45} = \sqrt{9 \times 5} = 3\sqrt{5}$.

12. E

Order matters in this problem, so remember you do not divide; you multiply! For the first integer, you have 5 options. For the second, you have 4. For the third, you have 3, which is answer choice (E).

13. D

The percent increase in the CEO's pay was $\frac{\$50 - \$5}{5} \times 100\% = 900$ percent.

The percent decrease in the factory workers' pay was $\frac{\$20 - \$10}{20} \times 100\% =$

50 percent. To find what percent greater 900 percent is than 50 percent, do the following: $\frac{900\% - 50\%}{50\%} \times$

100% = 1,700 percent, or choice (D).

14. D

Divide the \$9.4 million in private donations received by child safety organizations in September 1989 by the 38 organizations operating at the time.

The amount is approximately \$250,000.

15. C

From the line graph, you see that homeless aid groups took in about \$300 million in private donations, and animal rights groups about \$225 million. The ratio of \$300 million to \$225 million is 4 to 3.

16. E

In September 1989, \$9.4 million was privately donated to child safety, and in October 1989, \$9.9 million was privately donated. Percent change is $\frac{\text{change}}{\text{original}} \times 100$. The change is equal to

$9.9 - 9.4 = 0.5$ (the difference between private donations in September 1989 and October 1989). The original is equal to 9.4 (the amount of private donations in September 1989). The percent change is $\frac{0.5}{9.4} \times 100$, or approximately 5 percent. This is lower than the percent change in any of the other categories.

17. D

This is a pattern problem. The pattern has five digits: 06539. Divide 34 by 5, which gives you a remainder of 4. So

the 34th digit will be the fourth in the pattern, which is 3.

18. $\frac{48}{7}$

First, solve for x using the equation $\frac{7y}{2x} = 7$. Cross-multiply to find that $7y = 14x$. Dividing both sides by 14 yields $\frac{1}{2}y = x$. Substitute this expression into the first equation to get $3\left(\frac{1}{2}y\right) + 2y = 24$. Combine the like terms to get $\frac{7}{2}y = 24$; multiply both sides by $\frac{2}{7}$ to find $y = \frac{48}{7}$.

19. C

Because the question asks you to find the greatest value of x , make the average the largest it can be; in this case, make it 11. You have to use the number 11 because the question tells you the average is between 6 and 12 and that x is an integer. Now draw yourself an average pie. If you multiply the number of things (4) and the average (11), the total will be 44. Notice that choice (E) is 44, but it's a partial answer. To find x , solve $6 + 8 + 10 + x = 44$; $x = 20$, or choice (C).

20. A

Plug In! To find the area of quadrilateral $ABDE$, find the area of right $\triangle ABC$ and subtract the area of right $\triangle EDC$.

Make $a = 4$ and $b = 2$. Because $AB = BC$, we know that this triangle has a height and base that are both equal to 2. The area of ABC is $4 \times 4 \times \frac{1}{2} = 8$. The area of EDC is $2 \times 2 \times \frac{1}{2} = 2$. The area of $ABDE$ is $8 - 2 = 6$. Plug in for a and b and find answer choice A is the only one that works. To find the area of quadrilateral $ABDE$, find the area of right Δ . Both the base and the height of ΔABC are a , so the area equals $\frac{1}{2} \times a \times a$, or $\frac{a^2}{2}$. Both the base and the

height of $\triangle EDC$ are b , so the area equals $\frac{1}{2} \times b \times b$, or $\frac{b^2}{2}$. Therefore, the area of quadrilateral $ABDE$ is $\frac{a^2}{2} - \frac{b^2}{2}$.

SECTION 6

1. original and outlandish

Try working with the second blank first. The clues are that the fashions were “considered daring” and then “imitated.” Starting with the second blank, the sentence suggests that the fashions have changed from what they once were—in other words, daring. *Outlandish* is a good synonym for daring and it makes sense that, in the first blank, the fashions were *original* and then lost their impact because of excess imitation.

2. diverge

Take note of the time trigger “... at one time inseparable ... now,” which

indicates that the combined roles in Middle Eastern music are now not inseparable. You need a word that means divide or separate. *Divulge* starts with the proper root, but its meaning is way off. Meanwhile, neither *retreat* nor *retrench* means divide, while *fuse* is the opposite of what you want. *Diverge* is the best answer.

3. rebuked, perfidy, and expiate

Start with the second blank, which must mean something close to *an act of treachery*. *Perfidy* means this. Since his contemporaries believed Kazan had committed treachery, they would have “harshly criticized” him, so the first blank means rebuked. For the last blank, he was able to achieve *atonement*, which is what *expiate* means.

4. **soporific**

The sentence requires you to figure out the effect that “tranquilizers usually have,” and this is provided by the clue in the later part of the sentence, when we read that the “abuse of these drugs results in a failure to induce the much-desired sleep.” You can infer that the usual effect of tranquilizers is to produce sleep. *Soporific*, which means sleep-inducing, is the correct answer choice. While *sedulous* might remind you of “sedative,” it actually means hard-working.

5. **preternatural, preclude, and consonant**

The clue for the first blank is “are rejected by modern science in its attempts to find secular insights.” Otherworldly interpretations contrast

the secular, and the best choice for the first blank is *preternatural*. There would be a paradox only if scientists could hold non-secular beliefs. Therefore, a good word for the second blank is *prevent*, and a good phrase for the last blank would be *in agreement*. *Preclude* is synonymous with *prevent*, and *consonant* is synonymous with *in agreement*, making these the best answer choices.

6. **conformity** and **eccentricity**

Try working with the second blank first. The clue is “none of the family members were fearful ... of appearing or acting differently from other people.” Therefore, find a word for the second blank that means uniqueness. *Eccentricity* fits the bill. Considering the clue, “The Johnson’s were not known for their,” the two blanks must

be opposites. Eliminate *candor* and *vulgarity* based on the clue and the word choice for the second blank, and choose *conformity*.

7. E

In the last paragraph, the author discusses the difficulties inherent in measuring intergalactic distances. He notes that scientists use a standard candle in combination with the inverse square law to measure those distances.

8. C

The passage states in the third paragraph that brighter objects are closer than dim objects, so eliminate choice (A). The passage never specifies what scientists know about the age of astronomical objects, so eliminate choice (B). The first paragraph says that,

according to Hubble's law, "*objects farther away from Earth are receding faster than those closer.*" This means that the farther object will travel faster, so choice (C) is correct.

9. B

According to the last line in the paragraph, "By the inverse square law, galaxy B is ten times farther away than galaxy A, assuming, of course, that distance is the only factor affecting brightness." Therefore, if interstellar dust affects the brightness of an object, the brightness of the object is affected, and the distance scientists measure may be inaccurate.

10. C

According to the passage, "By the inverse square law, galaxy B is ten times

farther away than galaxy A, assuming, of course, that distance is the only factor affecting brightness.” Therefore, assuming that all other factors affecting brightness can be known, we can conclude that the brighter of the supernovas will be closer to Earth.

11. B

“Prozac lag” is a phenomenon for which there is currently no explanation, but neurogenesis may offer a solution. Answer (A) contradicts this. The passage offers “Prozac lag” as supporting evidence of a new theory, not disproving an old one, as choice (C) suggests, or disproving a new one, as choice (D) states. Answer (E) goes too far by discussing “unforeseen effects.” Choice (B) is the best option.

12. However, patients suffering from depression only begin to experience mood elevation weeks after beginning treatment.

The second paragraph has five sentences, so this question has five answer choices. For an “unexpected observation,” a good place to start would be to check the trigger words. The fourth sentence starts with the word “however.” While the effects should occur immediately, these don’t occur until weeks after starting treatment. The answer is the fourth sentence.

13. edifying and didactic

The blank describes Socrates’s conversations. The clue is “Socrates’s teachings have survived and continue to enlighten seekers of wisdom,” so the blank must mean instructional.

14/2/1807

Edifying and *didactic* are the closest in meaning. *Tedious*, *grating*, *inspiring*, and *rousing* could all be used to describe Socrates's conversations, but they do not match the clue.

14. satiate and **allay**

You would expect “the colossal meal” to fill someone up, but the sentence says that “failed to ... her voracious appetite.” Thus, she was not full, and the meal failed to satisfy. *Satiate* and *allay* are the best match. *Cadge* and *mendicate* mean the meal begged her hunger. *Exacerbate* and *provoke* go in the wrong direction.

15. iridescent and **pavonine**

The clue for this sentence is “the lovely rainbows they produce,” which suggests that the blank should be filled by

a word meaning colorful. Both *iridescent* and *pavonine* mean exactly that. Even if you don't agree that the blank necessarily refers to rainbows of color, the missing word does have to agree with *beautiful* due to the trigger and, and none of the other four options does: *Anodyne* means eliminating physical pain, *monocoque* means constructed in one piece, *parietal* mean college-related, and *saturnine* means gloomy.

16. **cauterized** and **inured**

The clue for this sentence is *callous*, so the blank must mean “used to,” or “didn't notice.” Choices (B), *cauterized*, and (E), *inured*, mean this. (F) is incorrect because he didn't notice the violence more, but rather noticed it less.

17. D

The conclusion of the argument is that the old formula for Megapower contained natural kiwi extract, while the new formula does not. The evidence is that Tasmania suffered a decrease in its kiwi exports. The assumption is that Megapower is not getting kiwi fruit from Tasmania. Choice (D) strengthens the argument by pointing out that kiwi imports have fallen in the country that produces Megapower, which would reinforce that assumption that the manufacturer is not getting kiwis from Tasmania. Choice (A) would weaken the argument by providing a potential alternate source for kiwi fruit. Choice (C) weakens the argument by providing evidence that the manufacturer of Megapower could be getting kiwi fruit from another

source. Choice (B) and Choice (E) are not relevant to the conclusion.

18. C

While the word *promulgated* can take on the meanings given in answer choices (A), (B), or (C), within the context of the sentence it is clear that Courbet is taking a stand on what he believes art should be. Therefore, answer choice (C) is closest to the correct meaning.

19. **“The argument has been made that the painting struck a blow for the independence of the artist, and that since Courbet’s work, artists have felt freed from the societal demands placed upon their work.”**

While the rest of the passage enumerates Courbet's ideas on painting, only this sentence points to the effect that Courbet's work may have had on other artists when it states that "since Courbet's work artists have felt freed from the societal demands placed on their work."

20. **A**

According to the passage, Courbet broke with convention by "striving to do something strikingly original." Only answer choice (A) provides that sense of defying a convention to do something original.

Chapter 19

Practice Test 2

Click [here](#) to download a PDF of Practice Test 2.

SECTION 1: ISSUE TOPIC

Directions:

You will be given a brief quotation that states or implies an issue of general interest and specific instructions on how to respond to that issue. You will have 30 minutes to plan and compose a response in which you develop a position on the issue according to the specific instructions. A response to any other issue will receive a score of zero.

“Studying foodways—what foods people eat and how they produce, acquire, prepare, and consume them—is the best way to gain deep understanding of a culture.”

Write an essay in which you take a position on the statement above. In developing and supporting your

position, you should consider ways in which the statement might or might not hold true.

SECTION 2: ARGUMENT TOPIC

Directions:

You will be given a short passage that presents an argument, or an argument to be completed, and specific instructions on how to respond to that passage. You will have 30 minutes to plan and compose a response in which you analyze the passage according to the specific instructions. A response to any other argument will receive a score of zero.

Note that you are NOT being asked to present your own views on the subject. Make sure that you respond to the specific instructions and support your analysis with relevant reasons and/or examples.

Fossil evidence indicates that the blompus—an extremely large, carnivorous land mammal—inhabited

the continent of Pentagoria for tens of thousands of years until its sudden decline and ultimate extinction about twelve thousand years ago. Scientists have determined that the extinction coincided with a period of significant climate change and with the arrival of the first humans. Some scholars theorize that the climate change so altered the distribution of plants and animals in the environment that the food chain upon which the blompus depended was irretrievably disrupted. Others contend that predation by humans is the more plausible explanation for the rapid population decline.

Write a response in which you discuss specific evidence that could be used to decide between the proposed explanations above.

SECTION 3: VERBAL REASONING

For questions 1 through 6, select one entry for each blank from the corresponding column of choices. Fill all blanks in the way that best completes the text.

1 of 20

The (i)_____ with which a statement is conveyed is frequently more important to the listener in determining the intended meaning than the actual words (ii)_____.

For example, a compliment, when delivered sarcastically, will be

perceived by the receiver as fairly insulting.

Blank (i)

inflection
pitch
accuracy

Blank (ii)

implied
repudiated
utilized

2 of 20

Though a film studio produces works that are (i) _____ and artistic, its priorities often dictate that creativity be (ii) _____ to a secondary position since the creative process can (iii) _____ the organization and hierarchy necessary to running a large company.

Blank (i)

expressive
tedious
tiresome

Blank (ii)

compared
uplifted
relegated

Blank (iii)

respond to
conflict with
coexist with

3 of 20

Science and religion each have core tenets that are considered _____; however, because some scientific tenets are in conflict with some religious ones, these tenets cannot all be correct.

historic
axiomatic
disputable
ubiquitous
empirical

4 of 20

Although most preventative medical ointments commonly in use would have (i) _____ an infection, the particular one Helen applied to her sores actually, much to her

dismay, (ii)_____ her
 (iii)_____.

Blank (i)

surrendered to
exacerbated
staved off

Blank (ii)

contributed to
detracted from
disbursed with

Blank (iii)

medicine
salve
affliction

5 of 20

A single (i)_____ remark can easily ruin the career of a politician, so most are trained to avoid such offhand remarks and instead stick to prepared talking points. This training can result in a lack of (ii)_____, however, and elicit merely (iii)_____, lukewarm responses from crowds.

Blank (i)	Blank (ii)	Blank (iii)
elated	spontaneity	ardent
glib	equanimity	tepid
pedantic	rigidity	morose

6 of 20

Oscar Wilde's *The Importance of Being Earnest* satirizes the _____ nature of upper crust British society; its characters take trivial concerns seriously while thoughtlessly dismissing important ones.

maladaptive
insincere
unusual
insignificant
shallow

For each of Questions 7 to 12, select one answer choice unless otherwise instructed.

Questions 7 through 10 are based on the following reading passage.

In 1798, economist Thomas Robert Malthus stated in his “Essay on the Principle of Population” that “population increases in a geometric ratio, while the means of subsistence increases in an arithmetic ratio.” However, Malthus’s dire prediction of a precipitous decline in the world’s population has not come to pass. The miscalculations in what has come to be known as the Malthus Doctrine are partly due to Malthus’s inability to foresee the

innovations that allowed vast increases in worldwide wheat production.

In the late nineteenth century, the invention of the tractor staved off a Malthusian disaster. While the first tractors were not particularly powerful, the replacement of animals by machinery meant that land that had been devoted to hay and oats could now be reclaimed for growth of crops for human consumption. Nevertheless, the Malthusian limit might still have been reached if crop yield had not been increased.

A natural way to increase crop yield is to supply the soil with additional nitrogen. In 1909, chemist Fritz Haber succeeded in combining nitrogen and hydrogen to make ammonia, the white powder version of

which, when added to the soil, improves wheat production. Haber nitrogen, however, was not widely used until later in the twentieth century, largely due to farmers' resistance to spreading an unnatural substance on their crops. Haber's invention had a further drawback: If applied in incorrect quantities, the wheat crop would grow taller and thicker, eventually toppling over and rotting.

Interestingly, in the late twentieth century the discovery of genetic engineering, which provides a means of increasing rice and maize production, met with equal resistance, this time from the environmental movement. Even without direct genetic engineering, it is likely that science

will discover new methods to improve agricultural production.

7 of 20

According to the passage, which of the following is true about Haber nitrogen?

- Haber nitrogen is more effective at increasing the yield of wheat crops than that of maize or oat crops.
- Undesired effects can result from the application of surplus quantities of Haber nitrogen.
- Haber nitrogen was the first non-naturally occurring substance to be applied to crops as fertilizer.

- Haber nitrogen may not be effective if applied at an improper time in wheat's growth cycle.
- Farmers were quick to adopt Haber nitrogen because it made their crops grow taller and thicker.

8 of 20

The passage implies all of the following EXCEPT

- world food production has kept pace with world population growth
- technological innovation is one factor that allowed for an increase in crop production

- farmers are not the only group that has opposed artificial efforts to increase crop yield.
- the Malthusian limit might well have been reached if new methods to increase crop production had not been found
- a Malthusian disaster would have been ensured if it were not for the invention of genetic engineering

[9](#) of 20

Which of the following, if true, would best represent Malthus' contention in the first paragraph?

- By 2040 the world's population increases marginally, and food production keeps pace with demand.

- By 2040 the world's population decreases marginally, and food production outstrips demand.
- By 2040 the world's population remains unchanged, and food production declines slightly.
- By 2040 the world's population has significantly increased, and food production has increased slightly.
- By 2040 the world's population has significantly decreased, and food production has decreased slightly.

[10](#) of 20

Which of the following most nearly means the word precipitous, as used in context?

- anticipated
- deliberate
- gradual
- risky
- sharp

Questions 11 through 12 are based on the following reading passage.

The dearth of natural resources on the Australian continent is a problem with which government officials there have long struggled. As long distance travel has become less of an obstacle, the tourism industry has become ever more important to the national economy. Tourism represents more than 10 percent of national export earnings annually, and in less developed regions such as the Western Territory, the percentage is much higher.

Unfortunately, this otherwise rosy prospect has one significant cloud on the horizon. In recent years, there has been a move towards

returning some of the land to the Aboriginal people. As Western society and culture have flourished on Australian soil, tribal people have been forced ever farther inland in an attempt to maintain their traditional ways of living, a desire that the government has striven to respect.

One of the central beliefs of the Aboriginal religion is that certain natural formations have spiritual significance and must be treated accordingly. Strict guidelines determine who may visit these sites and at what times. Unfortunately, many of these sites are the very natural wonders tourists flock to see. If non-Aboriginal people are forbidden to visit these natural wonders, many may choose not to vacation in a region

that sorely needs the income generated by tourism.

The Australian government has dealt with this dilemma thus far by trying to support both sides. The Aboriginal council is still trying to put an end to such use of certain sites, however, and it remains to be seen whether respect for tradition or economic desires will ultimately triumph.

[11](#) of 20

In the context of the passage, which of the following most closely matches the meaning of the phrase “otherwise rosy prospect has one significant cloud on the horizon”?

- A colorful sunset is marred by a dark storm cloud.
- A generally promising future has a potential problem.
- The view is beautiful but partially blocked.
- The future of the Aboriginal people is doubtful.
- Although the situation looks good, in reality it is hopeless.

[12](#) of 20

Consider each of the choices separately and select all that apply.

According to the passage, which of the following is a cause of the current dispute between the Aborigines and the Australian government?

- economic hardships in certain regions of the country
- increasing dominance by European norms and lifestyles
- limited natural resources in most of Australia

For questions 13 through 16, select the two answer choices that, when used to complete the sentence, fit the meaning of the sentence as a whole and produce completed sentences that are alike in meaning.

[13](#) of 20

George was a mercurial character; one moment he was optimistic about his prospects, and the next he was

_____.

- immoral
- hopeful
- witty
- morose

dour

buoyant

[14](#) of 20

Growing up in a wealthy suburb, she felt quite the _____ as she began her first job as a llama caretaker on a rural farm.

tyro

concierge

agronomist

cultivator

neophyte

curator

[15](#) of 20

William Shakespeare's *Macbeth* was based upon a highly _____ version of events that the playwright wrought from Raphael Holinshed's *Chronicles of England, Scotland, and Ireland*; King Duncan's death at the hand of Macbeth comprises the play's only historical truth.

- anachronistic
- effusive
- embellished
- prosaic
- serpentine
- colored

[16](#) of 20

While comic book artists such as Neal Adams demonstrated a more

thorough mastery of human anatomy than did the generation that preceded them, some readers wondered whether the superheroes they drew were really supposed to be so _____ that every detail of their musculatures would be visible through their clothing.

- thewy
- sinewy
- superfluous
- pneumatic
- flocculent
- atrophied

For each of Questions 17 to 20, select one answer choice unless otherwise instructed.

Questions 17 through 18 are based on the following reading passage.

One of the most curious structures in cellular biology is the telomere, a length of repeated bases located at the end of every chromosome that, unlike the rest of the DNA strand, carries no useful genetic information. While the telomere seems on the surface to be nothing more than a useless afterthought of DNA, a closer look proves that it is not only important, but also crucial to the functioning of any organism. Indeed, without this mundane structure, every cell division would be a

step into senescence, and the onset of old age would begin at birth.

Scientists have found that during cell division not every base of the DNA strand can be replicated, and many, especially those near the end, are lost. If, instead of telomeres, our chromosomes stored valuable genetic information at the end of the DNA strand, then cell division would cause our cells to lose the ability to code for certain information. In fact, many ailments associated with normal old age begin only after the telomere buffer has been exhausted through years of cell division.

Consider each of the choices separately and select all that apply.

Which of the following can reasonably be inferred based on the passage?

- An individual who aged faster than the average person may have had a shorter telomere buffer than the average person.
- Scientists once believed that telomeres served no useful purpose.
- If DNA degradation were absent, then telomeres would be less important to human health.

[18](#) of 20

The passage suggests that if telomere buffers did not exist

- problems associated with aging would begin earlier in life
- people would age so rapidly that almost no one would live past childhood
- cellular senescence would probably be prevented by DNA bases
- chromosomes would lose the ability to store genetic codes
- DNA strands would contain only useful genetic information

Questions 19 through 20 are based on the following reading passage.

Music education in America emerged in the early eighteenth century out of a desire to ensure that churchgoers could sing the weekly hymns in tune. In 1721, John Tufts, a minister, penned the first textbook for musical education entitled *An Introduction to the Singing of Psalm Tunes*. Tufts's pedagogical technique relied primarily on rote learning, omitting the reading of music until a student's singing abilities had improved.

In the same year that Tufts's publication emerged, Reverend Thomas Walter published *The Ground and Rules of Music Explained*,

which, while also focusing on preparing students to sing religious music, took a note-based approach by teaching students the rudiments of note reading from the onset. The “note versus rote” controversy in music education continued well into the mid-nineteenth century. With no curriculum to guide them, singing school teachers focused on either the rote or note method with little consistency.

[19](#) of 20

The author discusses Walter’s pedagogical technique in order to

- suggest that rote learning is superior to note learning

- present a contrast with Tufts's educational technique
- argue that rote learning improves a student's singing ability
- show the origin of Tufts's educational techniques
- show that rote learning was inconsistently practiced

[20](#) of 20

Select the sentence in the passage that best describes the endurance of the tension between pedagogical techniques.

SECTION 4: QUANTITATIVE REASONING

For each of Questions 1 to 8, compare Quantity A and Quantity B, using additional information centered above the two quantities if such information is given. Select one of the following four answer choices and fill in the corresponding circle to the right of the question.

(A) Quantity A is greater.

(B) Quantity B is greater.

(C) The two quantities are equal.

(D) *The relationship cannot be determined from the information given.*

A symbol that appears more than once in a question has the same meaning throughout the question.

1 of 20

Quantity A

$$\frac{98^7}{7^{63}}$$

Quantity B

$$\frac{2^7}{7^{49}}$$

- Quantity A is greater.
- Quantity B is greater.
- The two quantities are equal.
- The relationship cannot be determined from the information given.

2 of 20

5 is r percent of 25

s is 25 percent of 60

Quantity A

Quantity B

r

s

- Quantity A is greater.
- Quantity B is greater.
- The two quantities are equal.
- The relationship cannot be determined from the information given.

3 of 20

g and h are positive integers such that the value of g is twice the value of h .

Quantity A

The ratio of g to
1

Quantity B

The ratio of 1 to
 h

- Quantity A is greater.
- Quantity B is greater.
- The two quantities are equal.
- The relationship cannot be determined from the information given.

4 of 20

Quantity A

The average
(arithmetic mean)
of 67, 78, x , and
101

Quantity B

The average
(arithmetic mean)
of 66, 79, x , and
102

- Quantity A is greater.

- Quantity B is greater.
- The two quantities are equal.
- The relationship cannot be determined from the information given.

5 of 20

In a certain country the total weight of recycled newspapers increases annually by 0.79 million tons.

Quantity A

Percent increase
in the weight of
recycled newspa-
pers in 1989 over
1988

Quantity B

Percent increase
in the weight of
recycled newspa-
pers in 1990 over
1989

- Quantity A is greater.

- Quantity B is greater.
- The two quantities are equal.
- The relationship cannot be determined from the information given.

6 of 20

Quantity A

The total weight of m peanuts at a weight of $n + 3$ mg each

Quantity B

The total weight of n almonds at a weight of $m + 3$ mg each

- Quantity A is greater.
- Quantity B is greater.
- The two quantities are equal.

- The relationship cannot be determined from the information given.

7 of 20

Quantity A

$$5^{27}(575)$$

Quantity B

$$5^{28}(115)$$

- Quantity A is greater.
- Quantity B is greater.
- The two quantities are equal.
- The relationship cannot be determined from the information given.

8 of 20

Alejandro has a six-sided die with faces numbered 1 through 6. He rolls the die twice.

Quantity A

The probability that both rolls are even

Quantity B

The probability that neither roll is a multiple of 3

- Quantity A is greater.
- Quantity B is greater.
- The two quantities are equal.
- The relationship cannot be determined from the information given.

9 of 20

If $4(r - s) = -2$, then what is r , in terms of s ?

$\frac{-s}{2}$

$s - \frac{1}{2}$

$s - \frac{3}{2}$

$s + 2$

$2s$

10 of 20

At Tenderloin Pharmaceuticals, 25 percent of the employees take the subway to work. Among those who ride the subway, 42 percent transfer from one subway line to another during their commutes, and the rest do not transfer. What percent of all employees transfer lines?

percent

Click on the answer box and type in a number.

Backspace to erase.

[11](#) of 20

$$\frac{a + \frac{b}{c}}{\frac{d}{e}}$$

If the value of the expression above is to be halved by doubling exactly one of the five numbers a , b , c , d , or e , which should be doubled?

- a
- b
- c

d

e

[12](#) of 20

$$(\sqrt{5} - \sqrt{3})^2 =$$

$2 - 2\sqrt{15}$

$2 - \sqrt{15}$

$8 - 2\sqrt{15}$

2

$8 - 2\sqrt{5}$

[13](#) of 20

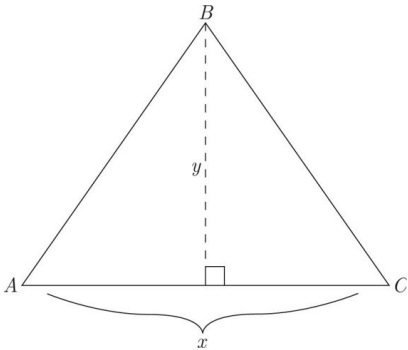

$\triangle ABC$ has an area of 108 cm^2 . If both x and y are integers, which of the following could be the value of x ?

Indicate all such values.

4

5

6

8

9

Questions 14 through 16 refer to the following graphs.

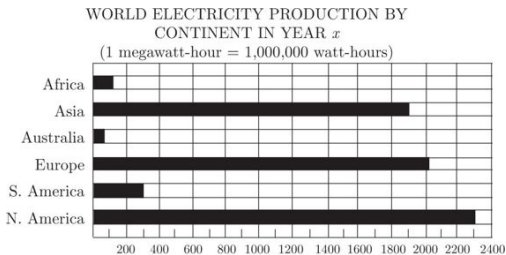

Electricity Production in Megawatt - hours

Note: Drawn to scale

DISTRIBUTION OF WORLD POPULATION
BY CONTINENT IN YEAR x

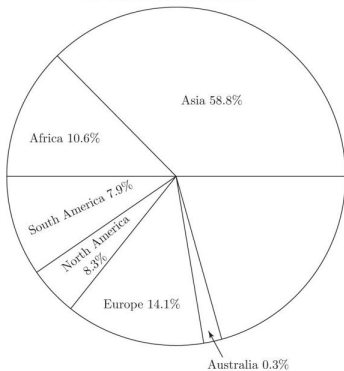

Note: Not drawn to scale

[14](#) of 20

In Year x , on which continent did electricity production most closely equal electricity production in Europe?

Africa

- Asia
- Australia
- South America
- North America

[15](#) of 20

In Year x , for which continent was the ratio of electricity production to percent of population the greatest?

- Africa
- Asia
- South America
- Europe
- North America

[16](#) of 20

In Year x , if South America had a population of approximately 368 million, what was the approximate population, in millions, of Africa?

- 494
- 470
- 274
- 150
- 39

[17](#) of 20

The average (arithmetic mean) weight of 5 crates is 250 pounds. The 2 lightest crates weigh between 200 and 205 pounds each, inclusive, and the 2 heaviest crates weigh between 300 and 310 pounds each, inclusive. If the weight of the fifth

crate is x pounds, then x is expressed by which of the following?

- $220 \leq x \leq 250$
- $230 \leq x \leq 260$
- $240 \leq x \leq 270$
- $250 \leq x \leq 270$
- $260 \leq x \leq 280$

18 of 20

A mathematician has devised a formula that produces a series of numbers $s_1, s_2 \dots s_x$ according to the principles $s_1 = 2, s_2 = 2, s_3 = 2$, and for $x \geq 4, s_x = 2s_{x-1} + s_{x-2}$. Which of the following equals s_6 ?

- 30
- 34

- 37
- 38
- 40

19 of 20

Y is a point on line segment XZ such that $XY = \frac{1}{2}XZ$. If the length of YZ is $4a + 6$, and the length of XZ is 68, then $a =$

Click on the answer box and type in a number.

Backspace to erase.

20 of 20

Talk show host Ralph Burke has exactly one guest on his show each day, and Burke's show airs every Monday through Friday. Burke always schedules politicians on Mondays and Wednesdays, actors on Tuesdays and athletes on Thursdays, but can have a guest of any one of these three kinds on Friday. No guest appears more than once per week on Burke's show. If Burke has five politicians, three actors and six athletes he could invite, and if no politician is also an actor or an athlete and no actor is also an athlete, how many different schedules of guests from Monday to Friday could Burke create?

- 30
- 1,200

- 3,600
- 4,500
- 6,300

SECTION 5: VERBAL REASONING

For questions 1 through 6, select one entry for each blank from the corresponding column of choices. Fill all blanks in the way that best completes the text.

1 of 20

Despite what _____ philosophies of child-rearing suggest, there is no imperative that the day-to-day action of raising a child be simple, unambiguous, and unchanging—no requirement, in other words, ensures that life follows philosophy.

inexact
aggressive
random
shameless
systematic

2 of 20

All the greatest chess players in the world know that it is folly to be

(i) _____ when facing a formidable opponent, as stubbornness will almost surely lead to mistakes that force a player to

(ii) _____ to the prevailing strategy of his or her opponent.

Blank (i)

finicky
obdurate
vituperative

Blank (ii)

capitulate
dissent
repudiate

3 of 20

The novel emphasizes the innate (i) _____ of all humans, showing how each and every character within the narrative is, ultimately, (ii) _____. This motif becomes tiresome due to its (iii) _____, however, as character after character is bribed, either explicitly or implicitly, into giving up his or her supposedly cherished beliefs.

Blank (i)

zealousness
corruptibility
optimism

Blank (ii)

adroit
cunning
venal

Blank (iii)

redundancy
triviality
subtlety

4 of 20

Although pirating software, such as borrowing a friend's copy of an

installation CD or downloading software from unapproved sources is (i) _____, many people continue to do so (ii) _____, almost as if they were unaware that such acts amount to theft.

Blank (i)

uncommon
illegal
difficult

Blank (ii)

savagely
sensibly
unabashedly

[5](#) of 20

Having squandered his life's savings on unprofitable business ventures, the _____ entrepreneur was forced to live in squalor.

former
unlikely
insolvent
perturbed
eccentric

6 of 20

Teachers of composition urge their students to (i)_____ in their writing and instead use clear, simple language. Why use a (ii)_____ vocabulary when (iii)_____ phrasing conveys one's meaning so much more effectively?

Blank (i)

exscind obloquy
eschew obfuscation
evince ossification

Blank (ii)

recreant
redolent
recondite

Blank (iii)

an arcane
a limpid
a droll

For each of Questions 7 to 11, select one answer choice unless otherwise instructed.

Questions 7 through 8 are based on the following reading passage.

Neurobiologists have never questioned that axon malfunction plays a role in neurological disorders, but the nature of the relationship has been a matter of speculation. George Bartzokis's neurological research at UCLA suggests that many previously poorly understood disorders such as Alzheimer's disease may be explained by examining the role of the chemical compound myelin.

Myelin is produced by oligodendrocyte cells as a protective

sheathing for axons within the nervous system. As humans mature and their neurochemistries grow more complex, oligodendrocyte cells produce increasing amounts of myelin to protect the **byzantine** circuitry inside our nervous systems. An apt comparison may be to the plastic insulation around copper wires. Bereft of myelin, certain areas of the brain may be left vulnerable to short circuiting, resulting in such disorders as ADHD, schizophrenia, and autism.

7 of 20

Consider each of the choices separately and select all that apply.

It can be inferred from the passage that the author would be most likely to agree with which of the following

statements regarding the role of myelin?

- The levels of myelin in the brain can contribute to the neurological health of individuals.
- Increasing the levels of myelin in the brain can reverse the effects of neurological damage.
- The levels of myelin in the brain are not fixed throughout the lifetime of an individual.

8 of 20

In the context in which it appears, **byzantine** most nearly means

- devious
- intricate
- mature

- beautiful
- electronic

9 of 20

The cost of operating many small college administrative offices is significantly reduced when the college replaces its heavily compensated administrative assistants with part-time work-study students whose earnings are partially subsidized by the government. Therefore, large universities should follow suit, as they will see greater financial benefits than do small colleges.

In the above argument it is assumed that

- replacing administrative assistants with work-study students is more cost-effective for small

colleges than for large universities

- large universities usually depend upon small colleges for development of money-saving strategies
- the financial gains realized by large universities would not be as great were they to use non-work-study students in place of the administrative assistants
- work-study students at large universities could feasibly fulfill a similar or greater proportion of administrative assistant jobs than what they could at small colleges
- the smaller the college or university, the easier it is for that

college or university to control
costs

Questions 10 through 11 are based on the following reading passage.

The nineteenth century marked a revolutionary change in the way wealth was perceived in England. As landed wealth gave way to monied wealth, investments became increasingly speculative.

A popular investment vehicle was the three-percent consol which took its name from the fact that it paid three pounds on a hundred pound investment. The drawback to the consol was that once issued, there was no easy way for the government to buy back the debt. To address the problem, the British government instituted a sinking fund, using tax revenue to buy back the

bonds in the open market. The fact that the consol had no fixed maturity date ensured that any change in interest rate was fully reflected in the capital value of the bond. The often wild fluctuation of interest rates ensured the consol's popularity with speculative traders.

10 of 20

Which of the following best describes the relationship of the first paragraph of the passage to the passage as a whole?

- It provides a generalization which is later supported in the passage.
- It provides an antithesis to the author's main argument.

- It briefly compares two different investment strategies.
- It explains an investment vehicle that is later examined in greater detail.
- It provides a historical framework by which the nature of the nineteenth-century investor can more easily be understood.

[11](#) of 20

In the second paragraph, select the sentence that describes a solution to a problem.

For questions 12 through 15, select the two answer choices that, when used to complete the sentence, fit the meaning of the sentence as a whole and produce completed sentences that are alike in meaning.

[12](#) of 20

Owing to a combination of its proximity and _____ atmosphere, Mars is the only planet in our solar system whose surface details can be discerned from Earth.

- viscous
- ossified
- rarefied

- estimable
- copious
- meager

[13](#) of 20

Using the hardships of the Joad family as a model, John Steinbeck's *The Grapes of Wrath* effectively demonstrated how one clan's struggles epitomized the _____ experienced by an entire country.

- reticence
- adversity
- repudiation
- quiescence
- verisimilitude
- tribulation

[14](#) of 20

The Mayan pyramid of Kukulcan is more than just _____ edifice; this imposing structure was built to create a chirping echo whenever people clap their hands on the staircase. This echo sounds just like the chirp of the Quetzal, a bird which is sacred in the Mayan culture.

- a venerable
- a humble
- a beguiling
- an august
- a specious
- a prosaic

[15](#) of 20

Some wealthy city-dwellers become enchanted with the prospect of trading their hectic schedules for a bucolic life in the countryside, and they buy property with a pleasant view of farmland—only to find the stench of the livestock so _____ that they move back to the city.

- bovine
- pastoral
- noisome
- atavistic
- olfactory
- mephitic

For each of Questions 16 to 20, select one answer choice unless otherwise instructed.

Questions 16 through 18 are based on the following reading passage.

Often the most influential developments initially appear to be of minor significance. Consider the development of the basic stirrup for example. Without stirrups horse and rider are, in terms of force, separate entities; lances can be used from horseback, but only by throwing or stabbing, and mounted warriors gain only height and mobility. In medieval times, a lance couched under the rider's arm, unifying the force of rider and weapon, would throw its wielder backwards off the horse at impact. Stirrups unify lance, rider,

and horse into a force capable of unprecedented violence. This development left unusually clear archaeological markers: With lethality assured, lances evolved barbs meant to slow progress after impact, lest the weight of body pull rider from horse. The change presaged the dominance of mounted combat, and increasingly expensive equipment destroyed the venerable ideal of freeman warriors. New technology demanded military aristocracy, and chivalric culture bore its marks for a millennium.

16 of 20

The primary purpose of the passage is to

- discuss the influence of a recent archeological discovery
- explore the societal significance of a technological innovation
- assess the state of research in a given field
- lament the destruction of certain social ideals
- explicate the physics of combat artillery

[17](#) of 20

It can be inferred from the passage that the author believes which of the following about innovations in military technology?

- Their study merits additional research.

- They had more lasting influence than did those of the ancient world.
- Most of them had equally far-reaching repercussions.
- Prior to their application, the military value of horses was considered insignificant.
- Many of them are archaeologically ambiguous.

[18](#) of 20

Select the sentence in the passage in which the author cites the physical effects of a technological innovation being discussed as an example of a previous generalization.

Questions 19 through 20 are based on the following reading passage.

Few mathematical constructs seem as conceptually simple as that of randomness. According to the traditional definition, a number is random if it is chosen purely as the result of a probabilistic mechanism such as the roll of a fair die. In their groundbreaking work regarding complexity and the limitations of formal systems, mathematicians Gregory Chaitin and A.N. Kolmogorov force us to consider this last claim more closely.

Consider two possible outcomes of throwing a fair die three times: first, 1, 6, and 2; second 3, 3, and 3. Now let us construct two

three-member sets based on the results. Though the first set— $\{1,6,2\}$ —intuitively seems more random than the second— $\{3,3,3\}$, they are each as likely to occur, and thus according to the accepted definition, must be considered equally random. This unwelcome result prompts Chaitin and Kolmogorov to suggest the need for a new standard of randomness, one that relies on the internal coherence of the set as opposed to its origin.

[19](#) of 20

Which of the following best describes the organization of the passage as whole?

- A concept is introduced; a traditional definition is put forward; a thought experiment is described; a new definition is proposed; the traditional definition is amended as a result.
- A concept is introduced; a traditional definition is supported by authorities; a thought experiment is described; the implications of the experiment are discussed.
- A concept is introduced; a traditional definition is considered and rejected; a thought experiment is described; a new definition is proposed.
- A concept is introduced; a traditional definition is called into question; a thought experiment

is described; the implications of the experiment are discussed.

- A concept is introduced; authorities are called in to reevaluate a definition; a thought experiment is described; the implications of the experiment are considered and rejected.

[20](#) of 20

Consider each of the choices separately and select all that apply.

Which of the following is an inference made in the passage above?

- The results of the same probabilistic mechanism will each be as likely as the other to occur.
- According to the traditional definition of randomness, two

numbers should be considered equally random if they result from the same probabilistic mechanism.

- Different probabilistic mechanisms are likely to result in similar outcomes.

SECTION 6: QUANTITATIVE REASONING

For each of Questions 1 to 7, compare Quantity A and Quantity B, using additional information centered above the two quantities if such information is given. Select one of the following four answer choices and fill in the corresponding circle to the right of the question.

(A) Quantity A is greater.

(B) Quantity B is greater.

(C) The two quantities are equal.

(D) *The relationship cannot be determined from the information given.*

A symbol that appears more than once in a question has the same meaning throughout the question.

1 of 20

$$\frac{x}{6} + 2 = \frac{6}{2}$$

$$\frac{y}{3} + 2 = \frac{9}{3}$$

Quantity A

$$\frac{(x - 1)}{y}$$

y

Quantity B

$$\frac{(y - 1)}{x}$$

x

- Quantity A is greater.
- Quantity B is greater.

- The two quantities are equal.
- The relationship cannot be determined from the information given.

2 of 20

Quantity A

The distance that Bob drives in 3 hours at an average speed of 44 miles per hour

Quantity B

The distance that Inez drives in 2 hours and 30 minutes at an average speed of 50 miles per hour

- Quantity A is greater.
- Quantity B is greater.
- The two quantities are equal.

- The relationship cannot be determined from the information given.

3 of 20

The height of a rectangular 3D figure is increased by p percent, its depth is decreased by p percent and its width is unchanged.

Quantity A

The volume of the new 3D figure if $p = 20$

Quantity B

The volume of the new 3D figure if $p = 40$

- Quantity A is greater.
- Quantity B is greater.
- The two quantities are equal.

- The relationship cannot be determined from the information given.

4 of 20

In $\triangle ABC$, $AB = AC$

Quantity A

Quantity B

The sum of the degree measures of angle B and angle C

90

- Quantity A is greater.
- Quantity B is greater.
- The two quantities are equal.
- The relationship cannot be determined from the information given.

5 of 20

12.5 percent of k is 80.

k is y percent of 80.

Quantity A

Quantity B

y

650

- Quantity A is greater.
- Quantity B is greater.
- The two quantities are equal.
- The relationship cannot be determined from the information given.

6 of 20

Set $P = \{a, b, c, d, e, f, g\}$

Set $Q = \{a, b, c, d, e, f\}$

$a, b, c, d, e, f,$ and g are distinct integers

Quantity A**Quantity B**Range of Set P Range of Set Q

- Quantity A is greater.
- Quantity B is greater.
- The two quantities are equal.
- The relationship cannot be determined from the information given.

7 of 20

Series F is defined as $F_n = F_{(n-1)} + 3$
and $F_1 = 10$.

Quantity A**Quantity B**The sum of F_4
through F_{10} The sum of F_6
through F_{11}

- Quantity A is greater.

- Quantity B is greater.
- The two quantities are equal.
- The relationship cannot be determined from the information given.

8 of 20

A number, n , is multiplied by 6. The product is increased by 24. Finally, the entire quantity is divided by 3. Which of the following expresses the final result in terms of n ?

- $\frac{n}{3} + 8$
- $\frac{n + 24}{2}$
- $2n + 8$
- $3n + 24$

○ $16n$

9 of 20

The average (arithmetic mean) of a and b is 10, and the average of c and d is 7. If the average of a , b , and c is 8, what is the value of d ?

Click on the answer box and type in a number.

Backspace to erase.

10 of 20

In the coordinate plane, square $ABCD$ has vertices at $A(3, 7)$, $B(3, 12)$, $C(8, x)$, $D(8, y)$. What is the area of $ABCD$?

- 16
- 20
- 25
- 30
- 36

[11](#) of 20

Houses Sold in July		
Week	Peter	Dylan
Week 1	4	9
Week 2	6	3
Week 3	10	10
Week 4	4	2

The table above shows the number of houses sold per week for the month of July by two real estate

agents, Peter and Dylan. What is the difference between the median number of houses sold per week by Dylan and the median number of houses sold per week by Peter?

- 0
- 1
- 2
- 5
- 6

[12](#) of 20

At Flo's Pancake House, pancakes can be ordered with any of six possible toppings. If no toppings were repeated, how many different ways are there to order pancakes with three toppings?

- 20
- 40
- 54
- 120
- 720

[13](#) of 20

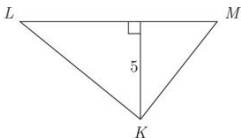

The area of triangle KLM is equal to the area of rectangle $ABCD$. If the perimeter of $ABCD$ is 16, what is the length of LM ?

- $\frac{3}{2}$

- 3
- $\frac{16}{5}$
- 5
- 6

Questions 14 through 16 refer to the following graph.

TELEVISION RATINGS* IN THE UNITED STATES
1980–1987

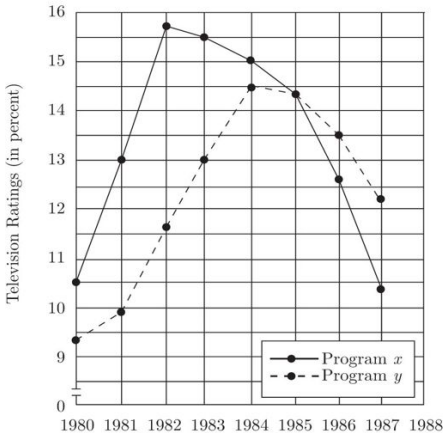

*Ratings equal the percent of television households in the United States that viewed the program.

Note: Figure drawn to scale

[14](#) of 20

For how many of the years shown did the ratings for Program y increase over the ratings for Program y the previous year?

- Two
- Three
- Four
- Five
- Six

[15](#) of 20

In 1995 there were 95 million television households in the United States. If, in 1983, there were 80 percent of the number of television households in 1995, then approximately how many television households, in

millions, viewed Program y in 1983
?

- 80
- 76
- 15
- 12
- 10

16 of 20

If there were 20 million television households in the United States in 1983, then the number of viewers of Program x is what percent greater than the number of viewers of Program y in 1983 ? (Ignore the percent sign when entering the answer).

Click on the answer box and type in a number.

Backspace to erase.

17 of 20

Each of the 576 houses in Tenantville is owned by one of the following landlords: Matt, Gavin, Angela, or Susan. Matt and Angela together own twice as many houses as Gavin and Susan own. If Gavin owns 100 more houses than Susan owns, and Matt owns 100 more houses than Angela owns, how many houses does Susan own?

- 46
- 142
- 146
- 192

[18](#) of 20

One-quarter of the cars that an automobile manufacturer produces are sports cars, and the rest are sedans. If one-fifth of the cars that the manufacturer produces are red and one-third of the sports cars are red, then what fraction of the sedans is red?

Click on each box and type in a number.

Backspace to erase.

[19](#) of 20

A candy jar has 4 lime, 10 cherry, 8 orange, and x grape candies. If Tom selects a candy from the jar at random and the probability that he selects an orange candy is greater than 20 percent, which of the following could be the value of x ?

Indicate all such values.

10

14

18

22

24

28

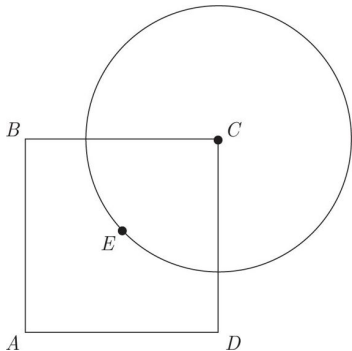

Square $ABCD$ and a circle with center C intersect as shown. If point E is at the center of $ABCD$ and if the radius of circle C is k , then what is the area of $ABCD$, in terms of k ?

- $\frac{k^2}{2\pi}$
- $\frac{\pi k^2}{2}$
- πk^2

k^2

$2k^2$

Chapter 20

Answers

Explanations

Practice Test 2

and

for

INTERPRETING YOUR RESULTS

After you check your answers on the following pages, fill out this sheet to interpret your results.

Analytical Writing

To evaluate your performance on the Analytical Writing sections, compare your response to the advice and samples in the Analytical Writing chapter.

Verbal Reasoning

Refer to the explanations to check your answers. Count the number of questions you got correct in each Verbal Reasoning section, and calculate the total number correct. Find

the section of the Interpretive Guide (below) that corresponds to your total to get an idea of how your performance compares to that of other test takers.

Test 2	# Correct
Section 3	
Section 5	
Total	

Quantitative Reasoning

Refer to the explanations to check your answers. Count the number of questions you got correct in each Quantitative Reasoning section, and calculate the total number correct. Find the section of the Interpretive

Guide (below) that corresponds to your total to get an idea of how your performance compares to that of other test takers.

Test 2	# Correct
Section 4	
Section 6	
Total	

Interpretive Guide

The table below provides a guide for interpreting your performance based on the number of questions you got correct in each subject.

Subject	Above Average	Average	Below Average
Verbal Reasoning	30–40	22–29	1–21
Quantitative Reasoning	33–40	24–32	1–23

Section 3

1. **inflection** and **utilized**

For the first blank, the trigger “more important” tells you to change direction from “actual words.” Also, *sarcastically* is an example of tone. Look for a choice that means tone. *Inflection* fits tone. *Pitch* is nonverbal, but it does not match the example of *sarcastically*. *Accuracy* does not fit. For the second blank, look for a word that means *conveyed* or *spoken*. *Utilized* is the best match. *Implied* and *repudiated* don’t fit.

2. expressive, relegated, and conflict with

Try working with the first blank first. The clue is *artistic*, and the trigger *and* indicates the first blank should be a word that is the same as artistic. *Expressive* is the best choice; neither *t tedious* nor *tiresome* works. *Though* changes the direction of the sentence—though the studio likes the creative/artistic aspect, something negative must be happening to creativity—it’s brought down to a secondary position. Eliminate *uplifted* and *compared* for blank (ii) because they are not negative, and choose *relegated*. Turning to the third blank, “organization and hierarchy” are in opposition to *creativity*, and *conflict with* makes the most sense.

3. axiomatic

You are given the clue that the beliefs “are in conflict” and “cannot all be correct.” Therefore, whatever goes into the blank must be synonymous with *correct* or something we can infer correctness from. The correct answer is *axiomatic*, which means self-evident or universally true. *Disputable* is the opposite of what the sentence requires, and *ubiquitous*, and *historic* are not synonymous with self-evident. Although *empirical*, meaning derived from observation, might fit science, it is not a good fit for religion.

4. **staved off, contributed to, and affliction**

The clue “Although most medical, preventative ointments commonly in use” tells you that most ointments would prevent an infection, but the one Helen used did not. Recycle the clue,

and put a word that means prevent in the first blank; *staved off* is the best match. Work with the second and third blanks together. The ointment did not prevent an infection, and the clue “much to her dismay” tells you that something bad happened. The only pair that makes sense together is *contributed to* and *affliction* because they tell you that the ointment made her problem worse.

5. **glib**, **spontaneity**, and **tepid**

For the first blank, the clue is *offhand remarks*, so the blank means something like “offhand.” *Glib*, which means “superficial or showing a lack of concern,” is the closest match for this. Sticking to *prepared talking points* can result in a lack of “excitement” or “naturalness,” which *spontaneity* matches. For the last blank,

you know the crowd's responses are *lukewarm*, so the answer for that blank is *tepid*.

6. **shallow**

The clue is the entire clause that follows the semicolon, “its characters take trivial concerns seriously while thoughtlessly dismissing important ones.” Look for a word that means superficial or petty to go in the blank. The only one that fits is *shallow*.

7. **B**

The third paragraph states that if incorrect quantities of Haber nitrogen were applied, “the wheat crop would grow taller and thicker, eventually toppling over and rotting.” Losing a crop would be an undesirable effect, making choice (B) the best answer.

Eliminate choice (A) because the passage doesn't compare the effects of Haber nitrogen on different kinds of crops. The passage doesn't provide any information to support choices (C) and (D). Choice (E) contradicts the passage, which says the farmers were wary of the substance.

8. E

According to the first paragraph, there has been no sharp decline in the world's population and, therefore, we can surmise that food production has been sufficient to allow for the existing population growth, as in answer choice (A). In the second paragraph, the author mentions the invention of the tractor as one of the factors that allowed more crops to be grown for human consumption. This reflects the technological innovation in answer

choice (B). In the last paragraph, the author notes that the environmental movement has opposed efforts at genetic engineering. Thus, answer choice (C) is implied as well. The author notes that increases in crop production through the invention of the tractor and ammonia prevented Malthus's predictions from being realized, and this rules out answer choice (D). The extent of the impact of genetic engineering is not clear. We don't know that a Malthusian disaster would have been a *certainty* without genetic engineering. Therefore, the correct answer is choice (E) because it is not implied.

9. D

The first paragraph states that Malthus believed that "population increases in a geometric ratio, while the means of subsistence increases in an

189/1897

arithmetic ratio.” More simply put, Malthus argued that population growth happens at a significantly faster rate than food production. Only answer choice (D) demonstrates this.

10. **E**

The first paragraph presents Malthus’s prediction about what would happen if population growth were to outstrip food production. If there were too many people and not enough food, you would expect a significant or rapid population decline. Look for a word to replace *precipitous* that is similar to *significant* or *rapid*. *Sharp* is the best word.

11. **B**

The “rosy prospect” refers to the previous paragraph’s discussion of the

booming tourism industry in Australia, which implies a positive future, and the “cloud on the horizon” refers to the conflict between the rights of the Aborigines and the need for the money from tourism, a potential problem. Choice (A) incorrectly interprets the quote as referring to a literal *horizon and prospect*. Choice (C) is also too literal, taking *prospect* to mean view. Choice (D) is incorrect because, although this may be true based on later information in the passage, it is not an accurate interpretation of this phrase. Choice (E) is too strong because the future is described as generally good, not hopeless.

12. A, B, and C

All three statements are given as sources of the conflict. Choice (A), economic hardship, is mentioned in the

third paragraph. Due to financial difficulties, many regions are unwilling to give up the income derived from tourists visiting Aboriginal lands. Choice (B) is discussed in the second paragraph. The expansion of Western culture is the reason that the Aborigines have moved inland and abandoned other sacred sites. Choice (C) is mentioned in the first sentence. Tourism is described as particularly important due to the “dearth of natural resources.”

13. **morose** and **dour**

The first part of the clue is “mercurial character,” which means George’s moods change frequently. The second part of the clue is “one moment he was optimistic about his prospects,” and the trigger is “the next he was.” Thus, the blank should be the opposite of

optimistic; look for words that mean pessimistic. *Morose* and *dour* are both similar to pessimistic. *Hopeful* and *buoyant* have the opposite meaning, and *witty* and *immoral* are not related.

14. **tyro** and **neophyte**

The clue is that she “began her first job.” Also, the contrast of “wealthy suburb” and “llama caretaker on a rural farm” suggests that she’d feel out of place or lacking in experience at her first job. Look for words that mean *beginner*. *Tyro* and *neophyte* are the only words that mean *beginner*. *Agro-nomist* and *cultivator* are traps for people who focused too heavily on the farm. *Concierge* and *curator* are traps for people who focused too heavily on *caretaker*.

15. **embellished** and **colored**

The clue “King Duncan’s death at the hand of Macbeth comprises the play’s only historical truth” tells you that the version of events related in *Macbeth* was not very accurate. Does *anachronistic* mean *inaccurate*? No; cross it out. What about *effusive*? No. In contrast, *embellished* works well, but *prosaic* and *serpentine* do not. Finally, *colored*—which, like *embellished*, means *misrepresented* or *distorted*—fits the blank nicely.

16. **thewy** and **sinewy**

The word that goes into the blank describes superheroes, of whom the clue phrase states that “every detail of their musculatures would be visible through their clothing.” Clearly, something like *muscular* is called for, and both *thewy*

and *sinewy* fit the bill. The other four words don't fit: *Superfluous* means unnecessary, *pneumatic* means full of air, *flocculent* means covered in wool, and *atrophied* means shriveled due to disuse.

17. A and C

Answer choice (A) is correct because the passage states that "... without this mundane structure, every cell division would be a step into senescence, and the onset of old age would begin at birth." Choice (B) is not correct because we have no information about what scientists used to think about telomeres. Choice (C) is correct because we are told that one function of telomeres is to mitigate the loss of DNA bases. If no bases are lost, then this role is not important any more.

18. A

The first paragraph says that without telomere buffers “every cell division would be a step into senescence, and the onset of old age would begin at birth,” and the last sentence of the passage states that “many ailments associated with normal old age begin only after the telomere buffer has been exhausted through years of cell division.” If the protection offered by the buffers didn’t exist, you could expect problems related to aging to start sooner, as choice (A) suggests. Choice (B) goes too far; though the passage speaks on the onset of old age at birth, we can’t be sure that almost no one would live past childhood. The passage provides no support for choices (C), (D), or (E).

19. B

The passage as a whole provides a short history of two types of early musical education, the rote method and the note method. Nowhere in the passage does the author come out in favor of either method, thereby ruling out choices (A) and (C). Given that Reverend Walter taught music by the note method he developed, answer choice (D) doesn't make sense. While it is true that rote learning was inconsistently practiced, as choice (E) states, this does not answer the question.

20. “The ‘note versus rote’ controversy in music education continued well into the mid-nineteenth century.”

The use of the word “controversy” in the final paragraph is the only indication the author gives that the decision between “note” or “rote” as a musical

learning technique was in any way contentious.

Section 4

1. C

When there are large exponents to work with and you cannot apply any of the exponent rules, you need to think about factoring to find common bases.

In Quantity A, 98^7 can also be expressed as $14^7 \times 7^7$. Quantity A is now reduced to $\frac{14^7 \times 7^7}{7^{63}} = \frac{14^7}{7^{56}}$. The num-

bers are still too large to compare with

Quantity B, and since the bases in Quantity B are prime numbers, try to reduce Quantity A even further. $14^7 = 2^7 \times 7^7$, so the expression can be rewritten as $\frac{14^7}{7^{56}} = \frac{7^7 \times 2^7}{7^{56}} = \frac{2^7}{7^{49}}$. The quantities are equal, the answer is choice (C).

2. A

Translate and solve each expression. The expression “5 is r percent of 25” becomes $5 = \frac{r}{100} \times 25$. So, $r = 20$. The expression “ s is 25 percent of 60”

becomes $s = \frac{25}{100} \times 60$. So, $s = 15$, and

Quantity A is greater.

3. A

Plug In for this question. Let $h = 3$, which makes $g = 6$. Quantity A equals $\frac{6}{1} = 6$ and Quantity B equals $\frac{1}{3}$. Quantity A can be greater than Quantity B, so eliminate answer choices (B) and (C). Because g and h are positive integers, Quantity A will always be greater than 1 and Quantity B will always be less than or equal to 1.

Quantity A will always be greater than Quantity B.

4. B

The average is the sum divided by the number of elements. Because three elements make up both averages, you can simply compare the sum of each set. $67 + 78 + 101 + x = 246 + x$, and $66 + 79 + 102 + x = 247 + x$. Thus, Quantity B is greater.

5. A

Plug In! Say there were 10 million tons in 1988. The percent increase was $\frac{0.79}{10}$. Then in 1989 there were 10.79 tons, so the percent increase from 1989 to

1990 was $\frac{0.79}{10.79}$. Quantity A must be greater.

6. D

Plug In. Make $m = 2$ and $n = 3$. For Quantity A, the weight of 2 peanuts at $3 + 3$ mg each is $2 \times 6 = 12$ mg. For Quantity B, the weight of 3 almonds at $2 + 3$ mg each is $3 \times 5 = 15$ mg. Eliminate choices (A) and (C). Plug In again to see if you can get a different result. Keep $m = 2$, and change n to 2. For Quantity A, the weight of 2 peanuts at $2 + 3$ mg each is $2 \times 5 = 10$ mg. For Quantity B, the weight of 2 almonds at $2 + 3$ mg each is $2 \times 5 = 10$ mg. Eliminate choice (B), and choose choice (D).

7. C

Remember when you have large exponents, try to break them down into their prime factors. You can rewrite Quantity A as $5^{27}(5)(115)$, or $5^{28}(115)$. The quantities are equal.

8. B

For Quantity A, there are three ways to get an even number (these are 2, 4, 6).

So, the probability of “rolling an even” and then “rolling an even” is $\frac{3}{6} \times \frac{3}{6} = \frac{1}{4}$

. For multiple independent events, multiply the probabilities. For Quantity B, there are four ways to not get a multiple of 3 (these are 1, 2, 4, 5). The

probability of “not rolling a multiple of 3” then “not rolling a multiple of 3” is $\frac{4}{6} \times \frac{4}{6} = \frac{4}{9}$. Quantity B is greater than

Quantity A.

9. B

There are variables in the answer choice, so Plug In. If $r = 2$, then $4((2) - s) = -2$. Divide both sides by 4 to find $2 - s = -0.5$. So, $s = 2.5$. The target answer is r , which is 2. Go to the answer choices and Plug In 2.5 for s . Answer choice (B) is the only answer choice that matches your target of 2.

10. 10.5

Plug In! Let's say there are 100 employees. 25% of the employees take the subway to work, so $\frac{25}{100} \times 100 = 25$. Of the 25 employees who ride the subway, 42% of them transfer during the commute so $\frac{42}{100} \times 25 = 10.5$. Therefore, 10.5 out of 100 employees transfer lines. This is 10.5%.

11. **D**

Plug In. If $a = 3$, $b = 6$, $c = 3$, $d = 5$, and $e = 10$, the value of the equation is

$$\frac{10\left(3 + \frac{6}{3}\right)}{5} = 10.$$

Half of 10 is your target of 5. Try doubling each variable to find the one that yields 5. The only one that works is doubling d to 10 so that the equation is

$$\frac{(10)\left(3 + \frac{6}{3}\right)}{10} = 5.$$

12. C

For this question, you can FOIL:
 $(\sqrt{5})^2 - (\sqrt{3})(\sqrt{5}) - (\sqrt{5})(\sqrt{3}) + (\sqrt{3})^2.$

This simplifies to $5 - 2\sqrt{15} + 3$, or $8 - 2\sqrt{15}$.

13. A, C, D, and E

Plug the information given into the formula for the area of a triangle to learn more about the relationship between x and y : $A = \frac{bh}{2} = \frac{xy}{2} = 108$.

The product of x and y is 216, so x needs to be a factor of 216. The only number in the answer choices that is not a factor of 216 is 5. The remaining choices are possible values of x .

14. B

Europe's electricity production (2,000 megawatt-hours) most closely matches that of Asia (1,900 megawatt-hours).

15. E

The ratio for North America is 2300 to 0.083 or, $\frac{2300}{0.083} = 27710$. This is the greatest ratio of any of the countries.

16. A

Africa's population is 10.6 percent on the pie chart; South America's is 7.9 percent. Right away, you can eliminate all of the answer choices that are

smaller than 368. Now you are left with choices (A) and (B). Because the question gives you South America's population (368 million), you can use a proportion to find the population of Africa. The proportion would look like this: $\frac{0.079}{368} = \frac{0.106}{x}$, where x is equal to the population of Africa. Cross-multiplying gives you $0.079 \times x = 0.106 \times 368$, and $x = 493.7$.

17. A

If the average of 5 crates is 250, then their total = $5 \times 250 = 1,250$. To find the high end of the range for the fifth

crate, make the other crates as light as possible: Make the two lightest crates 200 each, for a total of 400, and the two heaviest crates 300 each, for a total of 600; together, those four crates weigh 1,000 pounds, leaving 250 pounds for x . Because only choice (A) sets 250 pounds as the high end, you can eliminate choices (B), (C), (D), and (E).

18. B

Substitute 6 for x in the equation, $s_x = 2s_{x-1} + s_{x-2}$ and work carefully from there. $s_6 = 2s_5 + s_4$, which simplifies to $s_6 = 2s_5 + s_4$. However you don't know s_5 or s_4 . Use the equation to find these missing terms. $s_4 = 2s_3 + s_2$, and the problem tells you s_2 and s_3 are equal to 2. $s_4 = (2 \times 2) + 2$, which is 6. Now you need to find s_5 . Using

the equation, you get $s_5 = (2 \times 6) + 2$, which is 14. Now that you know s_5 and s_4 , go back to your original equation, $s_6 = 2s_5 + s_4$, and $s_6 = (2 \times 14) + 6$, which is 34.

19. 7

Always draw a figure when one is not provided. In this case, line segment XZ has a length of 68. Point Y is the midpoint of the segment, and $2XY = XZ$. To find the lengths of these segments, divide 68 by 2. Segment $YZ = 34$. Because $YZ = 4a + 6$, you know that $34 = 4a + 6$, and $a = 7$.

20. C

Make a spot for each day, and fill in the number of guests who could occupy that spot. Burke has 5 choices for Monday, 3 choices for Tuesday, 4

choices for Wednesday (because one politician was chosen on Monday), 6 choices for Thursday, and 10 choices for Friday (because 4 of the 14 potential guests have already been chosen). Multiply these to arrive at 3,600 different schedules.

Section 5

1. **systematic**

The clue is “simple, unambiguous, and unchanging.” The trigger word is “in other words.” The trigger word maintains the direction of the clue. Therefore, find a word that means regimented. *Systematic* is the best match.

2. **obdurate** and **capitulate**

Try working with the second blank first. The second blank is talking about what a player will be forced to do if they are stubborn. The clue is that the *mistakes* the player makes will lead to the *prevailing strategy of their opponent*. Because of these clues, we know that a word that means “to give in” would be a good match. *Capitulate* is the only word that works as *dissent* means to disagree and *repudiate* means to reject. Now look at the first blank. The first blank is referring to something all great chess players know. The clue tells us that they know *stubbornness will lead to mistakes that will force a player to capitulate to the prevailing strategy of their opponent*. As you can see, we needed to solve for the second blank first, as we would not have known what *stubbornness* would lead to without doing so.

Recycle the word *stubbornness* as your word for the blank. *Obdurate* is the only word that works for the first blank. *Finicky* means to be overly particular and *vituperative* means to be combative.

3. **corruptibility, venal, and redundancy**

The first two blanks are related, but there isn't a strong clue for either one in the first part, so let's start with the third blank. Since the motif is *tiresome*, the third blank must mean something close to "repetitive." *Redundancy* matches this. At the end of the paragraph, each character is *bribed ... into giving up ... beliefs*. So the first two blanks must mean "bribeable." *Corruptibility* in the first blank and *venal* in the second both match this.

4. **illegal** and **unabashedly**

For the first blank, the clues “pirating software” and “downloading software from unapproved sources” describe unauthorized activities, and *illegal* is the best fit. *Uncommon* and *difficult* are incorrect because the sentence says that “many people continue to do so.” If people are doing something despite its illegality and “almost as if they were unaware that such acts amount to theft” you could describe them as acting *brashly*. *Unabashedly* is the best fit.

5. **insolvent**

The phrase “squandered his life’s savings on unprofitable business ventures” tells you that the entrepreneur had no money left. The blank needs a word that means broke. *Former* and

unlikely are tempting choices, but they don't match broke. Eliminate them. *Eccentric* also doesn't match, while *perturbed* only describes the entrepreneur's possible feelings. *Insolvent* agrees with the clue, so keep it.

6. eschew obfuscation, recondite, and limpid

The key clue is that the teachers urge students to “use clear, simple language.” The trigger *instead* indicates that the phrase that goes into the blank will present an alternative to using clear, simple language, while the *and* indicates that the phrase will nevertheless agree with the clue. Something like “avoid difficult language” would be best: Difficult language is the alternative to clear, simple language, but the two phrases still agree because the difficult language is something to

avoid. Thus, *eschew obfuscation* is best: *Eschew* means avoid, while *obfuscation* means the act of hiding the meaning of something. *Excise obloquy* means to cut out critical language, while *evinced ossification* means to show excessive rigidity, neither of which is appropriate here. The second blank needs a word that means difficult or obscure because teachers call into question the use of difficult vocabulary; *recondite* means obscure and hard to understand. *Recreant* means cowardly; *redolent* means fragrant. The final blank requires a word like *clear* because that is the type of language that “conveys one’s meaning so much more effectively.” *Limpid* means easily understood, and so is correct.

7. A and C

Answer choice (A) is supported because the passage says that myelin protects the brain's circuitry. Answer choice (C) is supported by the fact that "as humans mature" increasing levels of myelin need to be produced. While the passage suggests that a lack of myelin leaves the brain vulnerable, that doesn't mean that increasing the levels of myelin will reverse damage.

8. **B**

In the passage, *byzantine* refers to the "circuitry inside our nervous systems." Previously, the circuitry is described as growing more complex, so you need to find a word with a similar meaning. Answer choice (A) is an alternate meaning for *byzantine*, but is not supported by the passage. Answer choices (C), (D), and (E) do not have meanings similar to *complex*.

9. D

The argument concludes that large universities should utilize work-study students rather than administrative assistants. The premise is that a similar strategy realizes a cost savings at small colleges. This is an argument by analogy. Hence, the argument assumes that there are similar conditions at small colleges and at large universities. Choice (D) says that students at universities are just as qualified to take over the administrative roles as they are in small colleges. In other words, the administrative jobs at universities are not appreciably different than those at colleges. For choice (A), whether the practice would be of greater benefit to the small colleges is out of scope. For choice (B), whether large universities usually depend on small colleges for ideas is out of scope.

For choice (C), the issue of non-work-study students is out of scope. For choice (E), whether anyone has an easier ride than anyone else is out of scope.

10. **A**

The first paragraph acts as an introduction to the rest of the passage. The author notes that in the nineteenth century “investments became increasingly speculative.” In the last paragraph, the author explains that due to fluctuating interest rates, the consol was popular with speculative investors. There is no support in the passage for (B), (C), or (D). Although the first paragraph provides a historical framework, as suggested in answer choice (E), it does not provide a way “by which the nature of the

nineteenth-century investor” could be understood.

- 11. To address the problem, the British government instituted a sinking fund, using tax revenue to buy back the bonds in the open market.**

The second paragraph has five sentences so this question has five answer choices. The third sentence begins, “To address the problem....” This is a clear indication that the sentence describes a solution to a problem. The correct answer is the third sentence.

- 12. rarefied and meager**

What sort of atmosphere would make Mars the only planet “whose surface details can be discerned from Earth?” You need a word that means

transparent or *thin* for the blank. *Viscous* takes you in the wrong direction, so toss it. The next choice, *ossified*, makes no sense; toss that one, too. In contrast, *rarefied* works well, so hang onto it. Meanwhile, a *copious* atmosphere would definitely not be easy to see through, so cross out that choice. *Meager* fits nicely and agrees with *rarefied*, making those two the best answers.

13. **adversity** and **tribulation**

The clue is “Using the hardships of the Joad family as a model.” Recycle *hardships*, and use POE. Does *reticence* mean *hardships*? No; cross it out. *Adversity* works, so leave it. Do the same for the remaining choices. Only *tribulation* agrees with *hardships*, so that’s the other correct answer.

14. **a venerable** and **an august**

The blank is a description of the pyramid. The clue is “imposing structure” because this is the only other description of the pyramid. *Venerable* and *august* are the only words that match *imposing*.

15. **noisome** and **mephitic**

The word that fills the blank must describe “the stench of the livestock,” which is so malodorous that it drives the newcomers back to the city; it must mean something like, well, *stinky*! Both *noisome* and *mephitic* are appropriate choices. The other words don’t work; if you were tempted by *olfactory*, realize that it simply means “related to the sense of smell” and does not actually describe a particular scent.

16. B

Answer choice (B) correctly sums up the purpose of the passage: It explores the significance—the creation of a military aristocracy and chivalric culture—of a technological innovation—the stirrup. Choice (A) is incorrect because nothing in the passage suggests that this discussion has a basis in recent discovery. Answer choice (C) is too broad for the limited subject matter discussed. Choice (D) is too extreme. Answer choice (E) is incorrect because the physics, while important in connecting the stirrup to its social effects, isn't really the point of the passage—and, in any event, the physics relates to cavalry, not artillery.

17. E

Answer choice (E) is supported by the passage because the sixth sentence suggests that the development of the barbed lance serves as an “unusually clear” marker. Choice (A) is incorrect because no additional subjects for research are brought up in the passage. Choices (B) and (C) require comparisons beyond the scope of the information in the passage: No other technology, ancient or medieval, was discussed. Answer choice (D), finally, is an extreme overstatement: Although the stirrup increased the military value of the horse, nowhere is it suggested that it had previously been considered militarily insignificant.

- 18. “Stirrups unify lance, rider, and horse into a force capable of unprecedented violence.”**

In this sentence, the author says that stirrups improve the ability of a lance and rider. This is an improvement on the issues discussed earlier when the author states that a “lance couched under the rider’s arm, unifying the force of rider and weapon, would throw its wielder backwards off the horse at impact.”

19. **D**

Choice (D) describes the organization of the passage. Answer choice (A) can be eliminated because the traditional definition is never amended. Answer choice (B) can be eliminated because the authorities do not support the traditional theory. Answer choice (C) can be eliminated because no new definition is proposed. Answer choice (E) can be eliminated because the

1628/1507
“implications of the experiment” are not rejected.

20. A and B

The author’s dismissal of the traditional definition of randomness rests upon the premises that the results of the same probabilistic mechanism will all have the same likelihood of occurring, and, as such, should be considered equally probable. The passage never mentions how the results of different probabilistic mechanisms relate to each other, so eliminate choice (C).

Section 6

1. A

Solve for x in the top equation, $\frac{x}{6} + 2 = \frac{6}{2}$, by reducing the right side: $\frac{x}{6} + 2 = 3$. Subtract 2 from both sides, and multiply both sides by 6 to find that $x = 6$. Solve for y in the second equation, $\frac{y}{3} + 2 = \frac{9}{3}$, by reducing the right side: $\frac{y}{3} + 2 = 3$. Subtract 2 from both sides, and multiply both sides by 3 to find that $y = 3$. If $x = 6$ and $y = 3$, Quantity A becomes $\frac{5}{3}$, and Quantity B becomes $\frac{2}{6} = \frac{1}{3}$.

2. A

Use the equation $distance = rate \times time$. Bob's time is 3 hours, and his rate is 44 miles per hour, so his distance is $3 \times 44 = 132$ miles. Inez's time is 2.5 hours, and her rate is 50 miles per hour, so her distance is $2.5 \times 50 = 125$ miles.

3. A

Plug In numbers! Let's say that the height is 10, depth is 20 and the width is 20. If the height is increased by 20%, the new height is 12. If the depth is decreased by 20%, the new depth is 16 and the width remains 20. The new volume is $12 \times 16 \times 20 = 3840$. If you use those same numbers but make the changes by 40%, the new volume is $14 \times 12 \times 20 = 3360$. Quantity A is greater. However, make sure you switch the numbers to check all possibilities. Make the height 20, the depth 10 and

the width 20. The volume of the new 3D figure if p is 20 is $24 \times 8 \times 20 = 3840$. The volume of the new 3D figure if p is 40 is $28 \times 6 \times 20 = 3360$. The quantities are the same regardless of what number you plug in. The answer is (A).

4. D

Draw the figure. Triangle ABC has two adjacent sides, AB and AC , that are equal in length. The angles that are opposite these sides, angles B and C , are also equal. One common triangle that has two equal sides is the 45:45:90 triangle. If angles B and C were both 45 degrees then their sum would be 90 and the answer would be (C). However, we know nothing about the third side of the triangle so it is possible that this is equal as well, which creates an equilateral triangle

with angles of 60. The sum of the angles in Quantity A is now 120. You cannot determine which is greater, therefore the answer is (D).

5. A

Translate: $\frac{12.5}{100} k = 80$, so $\frac{1}{8} k = 80$,

and $k = 640$. Use this information in

the other equation: $k = 640 = \frac{y}{100} \times$

80 , and solve for $y = \frac{10}{8} \times 640 = 800$:

Quantity A is greater than Quantity

B.

6. D

Plug In values for each set. If $P = \{1, 2, 3, 4, 5, 6, 7\}$ and $Q = \{1, 2, 3, 4, 5, 6\}$,

the range of Q is smaller. Eliminate choices (B) and (C). If you change P to $\{1, 2, 3, 4, 5, 7, 6\}$, and Q to $\{1, 2, 3, 4, 5, 7\}$, the range of Q is equal to that of P . Eliminate choice (A), and select choice (D).

7. A

One way to attack this problem is to list F_1 to F_{11} : 10, 13, 16, 19, 22, 25, 28, 31, 34, 37, 40. Notice that F_6 through F_{10} are included in both quantities, so focus on what's different. Quantity A is $F_4 + F_5$ and Quantity B is F_{11} . Quantity A is $19 + 22 = 41$, and Quantity B is 40. Alternatively, you know that F_4 has had 3 changes from F_1 . So, $F_4 = F_1 + 3(3) = 10 + 9 = 19$. F_5 has had 4 changes from F_1 , so $F_5 = F_1 + 3(4) = 10 + 12 = 22$. F_{11} has had 10 changes from F_1 , so $F_{11} = F_1 + 3(10) = 10 + 30 = 40$.

8. C

Plug In a number for n . Let $n = 5$. Because $5 \cdot 6 = 30$, the product is 30. Add 24 to get 54. Divide by 3 to get 18 as your target. If you Plug In 5 for n in each answer choice, only choice (C) matches the target: $2n + 8 = 2(5) + 8 = 18$.

9. 10

If the average of a and b is 10, then $a + b = 20$. Likewise, if the average of c and d is 7, then $c + d = 14$. If the average of a , b , and c is 8, then $a + b + c = 24$. Because $a + b = 20$, $c = 4$. If $c = 4$, then $d = 10$.

10. C

To find the area of a square, you need the length of a side. To find a side, find

the distance between two vertices. If A is at $(3, 7)$ and B is at $(3, 12)$, then length of a side is equivalent to the difference in the y -coordinates: $12 - 7 = 5$. So, side AB has a length of 5. Square this to find the area: $5^2 = 25$. The fact that there are variables for the y value of points C and D is irrelevant to solving this problem.

11. **B**

Get Dylan's median by putting his weekly sales into increasing order and finding the middle value. Dylan's set is $\{2, 3, 9, 10\}$, and his median is the average of 3 and 9, or 6. Next, do the same thing for Peter's sales numbers. Peter's set is $\{4, 4, 6, 10\}$, so his median is the average of 4 and 6, which is 5. The difference between the medians is $6 - 5 = 1$.

12. A

Order doesn't matter, so remember you must divide by the factorial of the number of decisions made. For the first topping, you have 6 options. For the second topping, you have 5 options. For the third topping, you have 4 options. $\frac{6 \times 5 \times 4}{3 \times 2 \times 1} = 20$, answer choice A.

13. E

Because you know the perimeter of the rectangle, you can figure out that both

BC and $AD = 5$. Thus, the area of the rectangle is $3 \times 5 = 15$. The area of the triangle is therefore also 15. Because the area of a triangle $= \frac{1}{2}bh$, you can put in the values you know to find $15 = \frac{1}{2}(b \times 5)$ and solve for the base, which is 6. LM is the base of the triangle, so $LM = 6$.

14. C

From 1981 through 1984, the ratings for Program y were higher than they were in the previous year.

15. E

There were 95 million times 80 percent, or 76 million, television households in 1983. Thirteen percent of them viewed Program y . 76 million times 13 percent (0.13) is 9.88 million, or approximately 10.

16. 19.23%

The number of television households that were viewers of Program x is 3.1 million. The number of television households that were viewers of Program y is 2.6 million. Set up the percent change formula, so $\frac{3.1 - 2.6}{2.6} \times 100 = 19.23\%$.

17. A

Plug In the answer choices, starting with choice (C). If Susan owns 146, Gavin owns 246, and together they own 392. Matt and Angela together would own 784, and the total number of houses would be 1,176. Choice (C) is too large, so also cross off (D) and (E). Try a smaller number. For choice (A), if Susan owns 46, Gavin owns 146, and together they own 192. Matt and Angela together would own 384 and the total number of houses would be 576.

18. $\frac{7}{45}$

Plugging In your own number is a great way to tackle this question. Multiply the denominators of $\frac{1}{4}$, $\frac{1}{5}$, and $\frac{1}{3}$

together to get 60, which will be an easy number with which to work.

Make the total number of cars 60. 60

$\times \frac{1}{4} = 15$ sports cars, and $60 - 15 = 45$

sedans. The number of red cars is $60 \times$

$\frac{1}{5} = 12$. The number of red sports cars

is $15 \times \frac{1}{3} = 5$, which means that there

are $12 - 5 = 7$ red sedans. The fraction

of the sedans that are red is $\frac{7}{45}$.

19. **A** and **B**

Plug In the answer choices. Start with one of the middle values, such as

choice (C). If there are 18 grape candies, then there are 40 total candies in the jar. The probability of selecting an orange candy is $\frac{8}{40}$ or 20 percent. The question states that the probability of selecting an orange candy is greater than 20 percent, so choice (C) cannot work. Values larger than 18 also do not work because when the denominator becomes larger than 40, the probability becomes less than 20 percent. The only choices that could work are (A) and (B).

20. E

Plug In for k , and let $k = 3$. CE is a radius and also half of the square's diagonal. If k is 3, then CE is 3, and the diagonal is 6. The diagonal of a square is also the hypotenuse of a 45 : 45 : 90 triangle. To get the hypotenuse from a side, you multiply by $\sqrt{2}$; so, to get a side from the hypotenuse, divide by $\sqrt{2}$. The sides of the square are each $\frac{6}{\sqrt{2}}$. To find the area, square the side to find $\left(\frac{6}{\sqrt{2}}\right)^2 = \frac{6^2}{\sqrt{2}^2} = \frac{36}{2} = 18$. Plug

$k = 3$ into the answers to find one that yields your target of 18. Answer choice (E) yields the target of 18.

Appendix:

Accommodated Testing

If you plan to request accommodations, you need a copy of the Testing Accommodations Request Form, which is part of the Bulletin Supplement for Test Takers with Disabilities or Health-Related Needs. The Bulletin Supplement is at <http://www.ets.org/s/gre/pdf/bulletin-supplement-test-takers-with-disabilities-health-needs.pdf>, or you can request it by phone at 866-387-8602 (toll-free for test takers in the United States, American Samoa, Guam, Puerto Rico, U.S. Virgin Islands and Canada) or 609-771-7780. You can also write to:

ETS Disability Services
P.O. Box 6054
Princeton, NJ
08541-6054

Available accommodations include the following:

- Extended testing time (There are no untimed tests.)
- Additional rest breaks
- Test reader
- Scribe
- Sign language interpreter for spoken directions only
- Screen magnification
- Large print

- Trackball
- Audio recording
- Braille

This is not an exhaustive list. ETS will consider any accommodation requested for a disability or medical condition.

Processing a request for accommodations takes time, so you should submit your request as early as possible (at least six weeks before you intend to take the test). The request must include the following:

- A completed Computer-Based Test (CBT) Authorization Voucher Request form and the proper test fee
- A completed Testing Accommodations Request Form

- A Certification of Eligibility: Accommodations History (COE), which verifies your use of accommodations at your college, university, or place of employment. In some cases, the COE is sufficient to document a disability and can be used in place of sending full documentation to ETS. If you are eligible to use the COE in this way, the documentation on file with the college, university, or employer must meet all ETS documentation criteria. Please see the Bulletin Supplement for details.

- Documentation (unless you are using the COE as described above)
 - If you have a psychiatric disability, physical disability or health-related need, or autism spectrum disorder, you must submit documentation.

- Documentation must also be submitted if your disability has been diagnosed within the last twelve months, regardless of the accommodations you are requesting.

The documentation you submit must meet the following criteria:

- Clearly state the diagnosed disability
- Describe the functional limitations resulting from the disability
- Be current: within the last five years for a learning disability or autism spectrum disorder, last six months for a psychiatric or physical disability or a health-related need, or last three years for other disabilities. Documentation of physical or sensory disabilities of a permanent or

unchanging nature may be older if it provides all of the pertinent information.

- Include complete educational, developmental, and medical history relevant to the disability
- Include a list of all test instruments used in the evaluation report and all subtest, composite, and/or index scores used to document the stated disability
- Describe the specific accommodations requested
- State why the disability qualifies you for the requested accommodations
- Be typed or printed on official letterhead and be signed and dated by an evaluator qualified to make the

1050/1507

diagnosis. The report should include information about the evaluator's license or certification and area of specialization.

If you have a learning disability, ADHD, a physical disability, a psychiatric disability, a hearing loss or visual impairment, or an autism spectrum disorder, refer to the ETS website at www.ets.org/disability for specific documentation requirements.

ETS will send you an authorization letter confirming the accommodations that have been approved for you.

- **Paper-Based Testing (PBT)**

When you receive your authorization letter, you are registered. The authorization letter will identify the testing location and test administrator. If the testing center cannot accommodate your request on the scheduled testing

date, you will be contacted by the test administrator to arrange an alternate test date.

- **Computer-Administered Testing (CBT)**

The authorization letter will include instructions that you must follow to schedule your test. **Do not schedule a CBT test until you receive your authorization letter.** When scheduling your test, be prepared to provide the authorization/voucher number and the information contained in the letter.

- **Alternate-Format Testing**

A representative from ETS Disability Services will contact you to confirm the accommodations approved for you and to schedule your test.

In most cases score reports contain no indication of whether a test was taken with accommodations. In rare instances, if an accommodation significantly alters what is tested (for example, if an entire test section must be omitted), a statement may be included with the score report indicating that the test was taken under nonstandard conditions. Score reports do not indicate the nature of the disability or the accommodations given. Score recipients also are reminded that test scores should be considered only one part of an applicant's record.

About the Authors

Doug Pierce has worked for The Princeton Review since 1999. In that time, he has helped hundreds of students on the GRE, SAT, GMAT, LSAT, and various other standardized tests.

Neill Seltzer has been coaching GRE test takers since 1992. He has helped hundreds of students in places as diverse as Hong Kong, Dubai, Miami, New York, Westport, and Vail master both the pencil and paper and the CAT GRE. In addition to teaching, Neill has written or contributed to many Princeton Review books and course materials including *The 500 Best Ways for Teens to Spend the Summer*, *11 Fake SATS*, and past editions of *Cracking the GRE*. In 2008, Neill earned his Masters of Architecture, giving him a first-

hand look at the process of applying to and succeeding at grad school.

GRE INSIDER

Admissions and Program Advice

While *Cracking the GRE* will prepare you for your exam, the *GRE Insider* will help you navigate what comes next. The bonus materials included here contain invaluable information about degree options, application considerations, and assorted fields of study. We wish you the best of luck on your studies and preparation for graduate school.

Table of Contents

Part 1: Beyond the GRE: Graduate School and More

Part 2: Introduction to Graduate School

Part 3: Graduate School Programs By Type

Art, Design, and Architecture

Biology and Life Sciences

Communications, Journalism,
and Media Studies

Computers and Technology

Education and Teaching

Engineering

Environmental Science, Natural
Resource Management, Conser-
vation, and Sustainability

Health Care and Public Health

Humanities and Cultures

Mathematics and Statistics

Physical & Earth Sciences

Psychology

Public Affairs & Policy

Social Sciences

Social Work

Part 1

Beyond The GRE:
Graduate School and
More

Graduate schools continue to draw more applicants, more enrollees, and more graduates in almost every field, with a few exceptions. The most important thing for a prospective graduate student to know is that there really is no simple, cookie-cutter way to describe graduate school. While many elements from program to program are similar, like taking classes, writing papers, conducting lab or field work, studying advanced theory and sitting for exams, the category is so broad that until now, we have not found a graduate school guide that does it justice. The goal of this *GRE Insider* is to pull back the covers on specific graduate program areas, examine the data and trends in each area (as well as associated careers), and highlight opportunities or things to think about before making this critical life choice.



So Much More Online

To learn more about graduate school admissions, check out your Premium Portal for articles, advice, and lots more.

One of the best ways we've found to describe graduate school is as a critical stage of career development. In fact for many careers discussed in this guide, an advanced degree is a requirement in order to get a job in that field. While some might joke that getting an advanced degree is a great way to put off getting a "real job", the reality is that graduate school programs are designed by professionals and researchers in each field to prepare students for the day-to-day demands and challenges of that specific profession.

For example, there are many master's programs considered to be "professional" because they are designed not to prepare graduates for further study necessarily, but to step right into a recognized profession. These jobs typically require some kind of certification or licensure that is regulated by state law, as is commonly the case for counselors, engineers, librarians, social workers, teachers, and therapists. In such cases, master's programs are often geared toward and will include elements that specifically prepare students for state-regulated exams.

Other master's programs are also considered professional, not because they launch students into careers in regulated professions, but because they prepare students for jobs that require a high level of proficiency in a field that has a fairly well-defined range of accepted practices. Examples of these fields include business management, government,

information management, journalism, and museum curation. There are still other master's programs designed to prepare students for either further study in the same field or for careers in which their general skills (though perhaps not their full range of content knowledge) are applicable. Examples of these programs can be found in the liberal arts disciplines, such as humanities and social sciences.

Doctoral programs prepare individuals to become experts in a particular field but also prepare graduates for specific career paths. Most PhD programs, for example, are designed explicitly to prepare students for careers as professors in higher education institutions or as researchers in the private, public, or nonprofit sectors. Other doctoral programs, such as those granting a Doctor of Psychology and Doctor of Education, are designed to produce practitioners in selected

professions, such as counseling or education. Given that the typical length of a doctoral program is in the range of five to eight years (depending on the discipline), it's even more important for prospective doctoral students to understand what kind of career they're preparing for than it is for prospective master's students.



Tune In Online

Your Premium Portal contains a bunch of helpful videos that cover content review for the GRE, plus vocab strategies, how to guidelines, and much more!

Whatever your reasons for reading this guide, we hope it gives you a better sense of which path to take for success in your future career. Good luck!

Part 2

Introduction to Graduate School

The decision to apply to graduate school is one that requires careful thought about your career goals, awareness of the different paths to reach your goals, and an understanding of the job market and prospects. In other words, will your degree help you reach your goals, and ultimately pay off?

For many careers in the graduate arts and sciences disciplines, obtaining a master's degree or a Ph.D. is required to be considered for certain jobs. An advanced degree can also provide an edge in increasingly competitive industries or for the best jobs in fast-growing industries.

Selecting a Program

Programs come in many shapes and sizes. Rather than blitzing every program with an

application, it is best to do your research, focus your attention and apply to carefully chosen schools. In some fields, it may be important to consider the prestige of the institution or even the professor with whom you want to conduct your research. Other fields that require state-based licensure might cause you to consider the location of your program for the best possible preparation.



Expert Advice

Visit www.PrincetonReview.com/GRE
for tried-and-true
GRE and graduate school
advice and information.

It might be helpful to divide potential graduate schools into categories based on your

chances of admission, just as you did when applying to undergrad. Select two schools you're fairly certain will accept you, two with whom you have a fighting chance and one school that you'll get into if lightning strikes. This is your target list; add more schools only if you have the time and money to do so.

Be sure to include making personal connections as part of your research process. While you can gather a lot of good information about programs online, make every effort to pick up the phone or go visit a school on your list. If you are going to spend three to six years in your program, it's important to make connections beforehand with the professors, ask questions and find out how your work (and goals) will be supported. Likewise, talk to graduate students in the program for a better picture of the atmosphere. It may be the only way to find out about the things you can't learn about online.

Degree Options

Do you need a master's or a PhD? Generally speaking, if you want to conduct research and development or teach in a postsecondary setting, a PhD is required.



PhD Degree

PhD programs are designed to give you extensive expertise in a specialized field; training you to pursue a life in academia as a professor or researcher (although not all candidates follow this path). Typically you spend five to six years earning your degree with the first three years focused on required coursework, writing a dissertation proposal, and

developing relationships with your professors. In years four through six, you take fewer (or no) courses and focus on writing your dissertation, which is supposed to constitute a new and meaningful contribution to knowledge in your field.

Some fields offer alternative terminal degrees to the PhD. For example, engineering offers a Doctor of Engineering Science (EngScD) while a Doctor of Psychology (PsyD) is a practitioner-based degree with less focus on research.

Master's Degree

Just like in college, first-year master's students take courses to fulfill degree requirements. However, the workload is heavier, the course topics are more specific, and much more is expected of you than in college.

At the beginning of the master's program, you'll choose (or be assigned) a faculty member who will serve as your advisor. This person will help you develop an academic focus and potential topics for your thesis or final project.

As a second year master's student, you decide on your research focus and—in one semester or two—complete your master's thesis or final project. If you show promise, you may be encouraged to continue toward a PhD.

Fields seeing more job applicants than job opportunities can experience growth in those opting for a PhD instead of a master's degree. Be sure to consider whether the programs you choose offer master's only or also have PhD options. Remember that within some programs, you can enroll for a master's degree and later choose to pursue a PhD if

you are so inclined; conversely, you can enroll in a PhD program and leave after earning your master's if the academic lifestyle fails to entice you further.

Letters of Recommendation

The value that an objective third-party can provide gives the application reviewing committee great insight into your value as a candidate for their program beyond the test scores, GPA, and your own personal statement. Most programs require three letters of recommendation, so consider that when selecting a recommender, much weight will be given to recommendations from academics in your field. However, practice-oriented programs, particularly ones that value fieldwork as part of your application, would likely value recommendations from the

professionals you worked with during your internship, job, or fieldwork. If in doubt about recommendations, consider what kinds of input your audience, in this case the admissions committee, would most like to help them make their decision, and don't be afraid to ask them either.



GRE for Business School?

More and more Business Schools are accepting GRE scores for admissions consideration. Check out *The Best 295 Business Schools* from The Princeton Review to learn more.

Essays

Putting yourself in the shoes of the admissions committee is a good rule of thumb for essays while research is the best way of preparing to actually write. Of course it's important to talk about the research you would like to pursue in a graduate program, but make sure you are able to demonstrate a solid understanding of what the school has to offer. Research their program strengths as well as their professors' research and publications; the more your areas of interest align with the programs' strengths, the easier it will be to write your essay. Also, be as detail-oriented as possible.

Work Samples and Interviews

Remember that the application and admission process is all about giving the admissions committee the most complete picture of you and your work as possible in a relatively short amount of time. Work samples and interviews are a great way to highlight your strengths as well as make yourself stand out from other applicants.

Reading through the application requirements early will help you pull together any necessary requirements, such as a portfolio or audio or video samples of your work (for areas like performing arts). Some programs will require or recommend an interview, so don't be afraid to practice! Talking about your goals for graduate school with others, and being able to think on your feet, will give

you an edge once you sit down for an interview.

Part 3
Graduate School
Programs By Type

ART, DESIGN, AND ARCHITECTURE

Creativity and artistic expression come to mind as the most important skills for careers in art and architecture. This is especially true in the studio arts or dramatic and theater arts. So why obtain a graduate degree at all—can't I just paint, act, or play music?

Well, yes, but ... just as a graduate degree in any other field provides relevant training and detailed knowledge required for a job in the field, an advanced degree in the arts gives students an opportunity to develop, refine, and practice their art with direct access to the resources, materials, and support they need to grow.

And for art historians, preservationists, conservators, as well as art and film critics, a balanced background of studying and creating the work provides a full preparation. Many of these programs focus on history, foreign languages, and cultural studies.

For the various fields within architecture, there is a unique “marrying” of creative design and construction with the cultural and social dynamic of the areas in which architects work, whether it is a streetscape, a renovation of a historic building, or designing a new home. Programs require that applicants have a year of college-level math, such as calculus or physics.

Degrees Offered

All areas of art and architecture have experienced growth in advanced degrees conferred,

most notably in architecture and related fields. For many fields in this area, the terminal degree is a master's degree, particularly for those offering the Master of Fine Arts (MFA).

In order to be a licensed architect, one must possess a BArch (a 5-year undergraduate program) or MArch. While a MArch takes about three years to complete, those entering the program with a BArch can often complete the program much faster. A Master's in Interior Architecture (MIA) or Landscape Architecture (MLA) generally take 2-3 years to complete, depending on undergraduate experience, and culminate in a thesis as well as oral and written exams.

While students in graduate programs for studio and performing arts receive the terminal degree in their field (MFA), many choose graduate school because it provides a unique

and focused opportunity in which to develop themselves as artists. Grad school provides the necessary preparation, resources, and exposure to dramatically influence one's success as an artist, writer, performer, or musician. Most programs last 2-3 years and culminate in, among other things, a presentation of work produced.

Quick Snapshot: Art and Architecture

SAMPLE DEGREE PROGRAM	NO. OF SCHOOLS OFFERING PROGRAM	DEGREE OPTIONS	APPLICATION CONSIDERATIONS *required or recommended
Architecture	Master's: 187 Doctorate: 46	MArch	Architecture degree or relevant coursework; portfolio of undergraduate work
Art History, Criticism & Conservation	Master's: 122 Doctorate: 54	MA, MS Conservation PhD	Study of at least one foreign language; classes in studio art or art history helpful
Drama & Dramatics/ Theater Arts	Master's: 139 Doctorate: 36	MA PhD	Portfolio of dramatic work
Historic Preservation	Master's: 18 Doctorate: 4	MA, MS, MSHP	Courses in art history, architectural history, or drafting
Industrial Design	Master's: 21 Doctorate: 1	MA, MFA (terminal degree)	Undergraduate degree or equivalent coursework in industrial design
Interior Architecture	Master's: 6 Doctorate: 0	MIA	Bachelor's degree in a related field such as architecture, fine arts, or art history
Landscape Architecture	Master's: 48 Doctorate: 2	MLA PhD	Courses in calculus and physics; work experience preferable
Playwriting and Screenwriting	Master's: 23 Doctorate: 5	MFA	One full-length dramatic writing sample
Studio Arts	Master's: 314 Doctorate: 47	MFA (terminal degree)	Portfolio demonstrating applicant has been actively practicing his/her art for some time

You can find more detailed information to guide you on the right path from these trade organization websites.

TRADE ORGANIZATIONS YOU SHOULD KNOW

American Film Institute

The American Film Institute is dedicated to

afi.com

advancing and preserving the art of the moving image.

American Institute of Architects

aia.org

News, conferences, education, government affairs and everything else an architect should know.

American Society of Landscape Architects

asla.org

The ASLA provides information on seminars, jobs, and history of the profession.

National Association of Dramatic and Speech Arts, Inc.

nadsainc.com

A professional organization for all dramatics professionals, including performers, educators, administrators, and students.

<p>National Trust for Historic Preservation nationaltrust.org</p>	<p>A not-for-profit organization dedicated to saving historic buildings, neighborhoods, and landscapes that form communities.</p>
<p>Writers Guild of America, West wga.org</p>	<p>Offers tools for writers of all genres and professions.</p>

Typical Admissions Requirements

Despite the wide range of degrees in art and architecture, all of them generally require a portfolio as part of the application. Many of the degree programs in art and architecture are directly linked to creative work, meaning that a portfolio is the best way for the admissions committee to review demonstrated

ability of the applicants. Here are some examples:

- Acting: live auditions or performance tapes
- Architecture/Interior Architecture: portfolio of work, typically created during undergraduate study
- Graphic Design: portfolio of work
- Landscape Architecture: portfolio of work that can include designs, drawings, and photography
- Playwriting/Screenwriting: at least one full-length dramatic writing sample
- Studio Arts: samples, photographs of work

For architecture programs, it is often required to have a bachelor's degree in the same or related field while many also require one year of undergraduate physics and mathematics, such as calculus.

General graduate school requirements:

- Bachelor's degree from an accredited college or university
- Official transcript(s) from all colleges or universities attended
- GRE General Test scores (different programs require different minimum scores)
- TOEFL score (if necessary)
- Academic letters of recommendation

-
- Letter of intent or statement of purpose
 - Application forms
 - Application fee

Some degree programs will also require:

- Interview or audition
- Supplemental essays or writing sample
- Proficiency in a foreign language (art history or architectural history)
- Portfolio of work, including audio, video, pictures and samples of work.

BIOLOGY AND LIFE SCIENCES

Biology is a natural science that involves the study of life and living organisms. There are many subdivisions of biology, categorized by the scale and method with which they approach the subject: biochemistry, molecular, cellular, physiology (organs, tissues, organ systems), and ecology. Within these subdivisions, one typically focuses on either basic or applied research.

Much of the grant-funded basic research serves as a starting point for applied research, which finds practical applications of biological knowledge in areas as diverse as new drugs, treatments, and medical diagnostic tests, increased crop yields, and new biofuels.

A career path for those who are interested in studying biology and life sciences is pharmacology. Pharmacologists are often thought of in tandem with toxicologists, as both research the effects of chemicals on cells. However, toxicologists examine the effects of poisons on cells while pharmacologists remain focused on drug-related chemical interactions.

Advanced degrees are required for many jobs in this area. A PhD is required for researchers seeking funding and post-secondary teachers while a master's degree can also be useful in the sales, marketing and publication aspects of biological sciences.

Degrees Offered in Biology and Life Sciences

An MS in biology and life sciences generally takes 2-3 years to complete. Masters programs culminate in a written examination, as well as a thesis with oral defense. A PhD is generally required for those expecting to conduct independent research, especially in academia, or for high-level administrative positions. You can expect to spend 5-6 years of full time study and research in a PhD program.

Some programs, like neuroscience and toxicology, are inherently interdisciplinary and combine disciplines with other graduate departments. Those that offer masters degrees in neuroscience are often steps toward PhDs or combined MD/PhDs. Likewise, a masters degree in toxicology is rarely seen as

terminal—most students spend another four plus years earning their PhD.

Quick Snapshot: Biology and Life Sciences

SAMPLE DEGREE PROGRAM	NO. OF SCHOOLS OFFERING PROGRAM	APPLICATION CONSIDERATIONS (*required or recommended)
Biochemistry	Master's: 155 Doctorate: 124	GRE Subject in Biochemistry, Cell and Molecular Biology
Biology, Biomedical Sciences	Master's: 402 Doctorate: 217	Coursework in biology, GRE Subject Test in Biology
Ecology	Master's: 52 Doctorate: 47	Coursework in sciences, especially upper level biology or environmental science
Molecular Biology	Master's: 85 Doctorate: 52	Some schools require a minimum GPA and undergraduate coursework in organic chemistry, physics, and calculus
Neuroscience*	Master's: 75 Doctorate: 82	If not a neuroscience major, then coursework in natural sciences
Toxicology	Master's: 35 Doctorate: 34	Undergraduate major or significant course work in biology, chemistry, or biochemistry
Zoology/Animal Behavior	Master's: 26 Doctorate: 24	Emphasis placed on research interest and work experience; some require GRE Subject Test in Biology

* Neuroscience is interdisciplinary, and programs and coursework may be found in psychology, molecular biology, biochemistry, and others.

You can find more detailed information to guide you on the right path from these trade organization websites.

TRADE ORGANIZATIONS YOU SHOULD KNOW

American Board of Clinical
Pharmacology
abcp.net

Recently created organization that administers an optional accreditation for clinical pharmacologists.

American Institute of Biological Sciences
aibs.org

A membership organization advancing research, education, and public policy issues for the biological sciences.

	Publishes a peer review journal.
Society for Neuroscience sfn.org	World's largest organization of scientists and physicians devoted to understanding the brain and nervous system. Includes an extensive Higher Education and Training section.
Association of Zoos and Aquariums aza.org	Links to job opportunities, conferences, and professional training opportunities.

Society for Human Ecology
societyforhumanecology.org

The society is a “international interdisciplinary society” whose mission is to promote “the use of an ecological perspective in research and application.”

Society of Toxicology
toxicology.org

Plenty of information about schools, degree grants and fellowships, links to career information, and other resources.

Typical Admissions Requirements

While many programs in biology and biological sciences might not require a specific major for admission, if they require a GRE Subject Test in either Biology or Biochemistry, Cell and Molecular Biology, then an undergraduate major or significant coursework is typically the best preparation.

General graduate school requirements:

- Bachelor's degree from an accredited college or university
- Official transcript(s) from all colleges or universities attended

- GRE General Test scores (different programs require different minimum scores)
- TOEFL score (if necessary)
- Academic letters of recommendation
- Letter of intent or statement of purpose
- Application forms
- Application fee
- Interview

Some degree programs will also require:

- GRE Subject Test: Biology

- GRE Subject Test: Biochemistry, Cell and Molecular Biology
- Curriculum vitae
- Research statement (as part of letter of intent)

COMMUNICATIONS, JOURNALISM, AND MEDIA STUDIES

Radio, TV, Internet, smartphones and tablets ... the evolution of media consumption has driven dramatic changes and opportunities in the field of communications, journalism, and media studies.

Companies such as Google, Facebook, YouTube, Tumblr, Vine, and Twitter, along with easy-to-use technology and publishing tools (digital cameras, free blogging sites) give anyone with access to a computer or smartphone the opportunity to reach an audience with their message. 24-hour news channels (and their companion websites or social media outlets) mean that news and

information are pumped out with unprecedented speed and volume.

Just as important in this evolution are the communications professionals who either create, or react to, the news on behalf of their employers. These days, it goes beyond for-profit companies and government organizations to include nonprofits, school districts, and yes, celebrities and personalities.

So what distinguishes an amateur from a professional? An advanced degree in communications, journalism or media studies provides a graduate student with the skills she needs to be an effective and educated resource, honing any raw skills and nurturing a passion for the field. With rapidly changing technologies and new social media outlets, students can learn the latest trends and technologies to understand how they can work together for the biggest impact. A graduate

degree can also give professionals in this area of study the solid background and experience to strike out on their own with more credibility.

Degrees Offered

The few PhDs pursued in this field are for post-secondary teaching and research, though there has been a a small surge in PhDs with 25 percent growth in the past five years. The majority of the 29,000 enrollees in this discipline pursue a master's degree.

Though programs vary by institution, if you want to report the news (writing, broadcasting, or publishing), you'd probably want to look at journalism programs. If you want to study forms of communication, methods, culture, or media, then you probably want to look into communications programs. Again,

research both departments (sometimes housed in the same department) to determine the best path for your career.

The Master of Arts tends to be more common than the Master of Science in journalism, and the differences between programs vary from institution to institution. Remember, a broad knowledge of history and current events strengthens the quality of your work in the field while perseverance and experience tend to play a big role in making a good journalist great. Try to find programs that teach more than just core skills and feature a depth of writing experiences and frequent fieldwork. Some programs also provide the opportunity to focus in a particular subject area such as health care, science, business, etc. Master's programs in communications also offer a range of foci including advertising and marketing, politics, law, public policy, and the global and cultural

aspects of communication in society or within an organization.

Depending on your career goals and your industry of preference, combined or interdisciplinary degrees can be found at many institutions, depending on where they house their communications, journalism and media studies programs.

MA Journalism (2-3 years)

MS Journalism (1-2 years)

MA Communications or Mass Communications (2-5 years)

BA / MA Journalism (starting junior year of college) – 5 years

PhD Communications or Journalism – 5-7 years, including dissertation

Quick Snapshot: Communications, Journalism, Media Studies

SAMPLE DEGREE PROGRAM	NO. OF SCHOOLS OFFERING PROGRAM	DEGREE OPTIONS	APPLICATION CONSIDERATIONS (*required or recommended)
Communications and Media Studies	Master's: 81 Doctorate: 35	MA PhD	PhD candidates need experience; others do not but background courses a bonus
Journalism	Master's: 100 Doctorate: 12	MA, MS PhD	Background courses and sample work helpful; required for PhD candidates
Mass Communications/ Media Studies	Master's: 69 Doctorate: 31	MA, PhD	
Radio and Television	Master's: 32 Doctorate: 7	MA PhD	

You can find more detailed information to guide you on the right path from these trade organization websites.

TRADE ORGANIZATIONS YOU SHOULD KNOW

The Associated Press
ap.org

The AP is the momma bear of all journalistic agencies.

The Poynter
Institute
poynter.org

Its motto, “Everything you need to be a better journalist,” says it all.

American Society of Magazine Editors
magazine.org/asme

The American Society of Magazine Editors is the professional organization for print and online magazine editors. Its website lists jobs, hosts discussion boards, and offers courses for junior editors, among other things.

National Communication Association
natcom.org

The National Communication Association advances communication as the discipline that studies all forms, modes, media and consequences of communication through

	humanistic, social scientific and aesthetic inquiry. Find resources, publications, and careers on their website.
National Press Photographers Association nppa.org	Promotes photojournalism with competitions, workshops & seminars, and job listings.

Typical Admissions Requirements

Experience in journalism, whether in the classroom or on the streets, is a plus but not required. Writing samples from undergraduate study, undergraduate GPA, recommendations, essays and, in some cases, GRE scores are required. While undergraduate

prerequisites vary, most programs require a bachelor's degree in a related field.

General graduate school requirements:

- Bachelor's degree from an accredited college or university
- Official transcript(s) from all colleges or universities attended
- GRE General Test scores* (different programs require different minimum scores)
- TOEFL score (if necessary)
- Letters of recommendation
- Letter of intent or statement of purpose

- Academic or professional writing samples
- Application forms
- Application fee

*Not required for all programs

COMPUTERS AND TECHNOLOGY

The field of computers and information technology includes three main disciplines: computer science, information systems, and information technology. The fields do overlap in terms of certain training and curriculum. A bachelor's degree is sufficient for many careers in these fields, but for those looking to advance within their organizations, manage teams, or teach, a graduate degree boosts your potential. In addition to Master of Science degrees, one might consider an MBA with a focus in technology.

Graduate programs focus on both theoretical frameworks, along with applied research and lab work. Because this is a rapidly changing field, a strong theory-based knowledge

coupled with a practical orientation keeps students not only current, but in some cases on the cutting edge of advancing new technologies.

Computer scientists contribute to new technologies, including interactive multimedia and virtual reality systems. Time is divided between class and lab work to ensure that students are equipped with the necessary skills in software development, systems development, and new computer systems creation.

Information technology covers the entire spectrum of computer-based content, and those who undertake study in this field will learn about it all. Courses cover computer hardware and software; how to view and send information by computer plus how to adapt, control, and improve the experiences had by computer users. In addition, graduate

students will learn how to create and modify the very systems that transmit the information—and how to best distribute that information to the target audience. Study will also include web-based computer applications, the fundamentals of e-commerce, the importance of web security, ethical issues and finally, how information technology affects business and society.

Those interested in more of a management-based career might want to consider a graduate program in management information systems (MIS). Studies in MIS will include management strategies and theories, how management can best use information systems and applications and security. You'll also learn how skillful use of information systems can lead to business solutions, help with decision-making and ways to improve the corporation.

Degrees Offered in Computers and Technology

Advanced degrees in computer science include either the Master of Arts or Master of Science, and of course, the PhD. Graduate students study broad, theoretical frameworks and then exercise that knowledge through lab work. Many who choose to pursue a doctorate select a concentration. Be sure to look for programs that produce and contribute to the latest research in computer science given that it is a rapidly changing field.

Information Science

Information Technology

Management Information Systems (MIS)

Systems Engineering

Web/Multimedia Management

Graduate work in information technology covers everything from hardware and software to managing and transmitting the information as well as the end-user experience. Your hands-on graduate work culminates in a MS in information technology or information technology and management. Students wishing to teach or pursue more research can advance with a PhD program in either information technology or another computer-related field. For those interested in a more management-based IT career, consider an MS in management information systems (MIS), which prepares graduate students for management careers in technology. Alternatively, one could pursue an MBA with a focus or concentration in information systems.

Quick Snapshot: Computers and Technology

SAMPLE DEGREE PROGRAM	NO. OF SCHOOLS OFFERING PROGRAM	DEGREE OPTIONS	APPLICATION CONSIDERATIONS (*required or recommended)
Computer Science	Master's: 314 Doctorate: 229	MA, MS PhD	Higher math and computer programming courses
Information Science	Master's: 108 Doctorate: 40	MS PhD	Computer sciences background
Information Technology	Master's: 32 Doctorate: 24	MS IT, MS ITM PhD	Proficiency in computer science, basic computer programming, and higher mathematics
Computer Information Systems	Master's: 149 Doctorate: 19	MS, CIS PhD	Accounting, statistics, calculus, and computer programming; some require work experience.

You can find more detailed information to guide you on the right path from these trade organization websites.

TRADE ORGANIZATIONS YOU SHOULD KNOW

Association of Information Technology Professionals
aitp.org

Education, peer support, and information for IT professionals in government, industry and academia.

HDI

thinkhdi.com

The largest association for IT service and support professionals produces numerous publications, hosts several symposiums and conferences each year, and certifies hundreds of help desk and service desk professionals each month.

Society for Information Management
simnet.org

Provides information and a community of shared experience among professionals.

TechAmerica
TechAmerica.org

Association devoted to researching and influencing technology policy in the U.S.

EDUCATION AND TEACHING

Many enter the teaching profession in order to make that connection with children or young adults where the proverbial light bulb goes on and the student “gets it.” While the monetary rewards in teaching may not be substantial, the personal satisfaction in helping students develop intellectually and socially is a driving force behind the decision to teach.

Thanks to projected population growth, enrollment increases are expected across all grade-levels and so the outlook for teaching professionals is good. However, increased demands placed on teachers and administrators alike, meaning that it takes a special talent to be a successful classroom teacher or

an effective administrator. Increased accountability, emphasis on standardized testing, more ESL students and growing classroom sizes are just a few of the challenges new teachers face every day. The number of advanced degrees conferred continues to grow overall, with Master's degrees growing at 6% but doctorates growing at 27%. Demand for teachers continues to be highest in rural and urban areas, or those who specialize in bilingual education, math and science, and special education.

Degrees Offered in Education and Teaching

Enrollment in post-graduate education programs is up by almost 50 percent since the new millennium while the growth in master's degrees conferred has grown 48 percent over that same time period. There are literally

thousands of programs in education, many of which require a teaching credential. Those who do not have a valid teaching credential or even an undergraduate background in education should look for programs that allow students to pursue licensure during their course of study.

For special ed (MS, MEd), Elementary and secondary school teaching (MS, MA, MEd), MS and MA programs usually require students to write a culminating thesis based on classroom research, whereas MEd programs usually do not. MS programs may also require more class work in methodology and research than MA or MEd programs. Most of these programs can be completed in one to two years with flexible part-time, evening or summer options for current teachers.

Master's programs in educational administration usually span about one or two years

and require successful performance in advanced level coursework, as well as participation in a practicum, research project, or internship. Some schools also require students to complete a master's thesis. After completing a master's degree in educational administration, students may choose to continue their studies in an Educational Specialist (EdS) program, designed for students who want to engage in advanced fieldwork, internship experience, or research in a specific area of education. Doctoral programs in educational administration usually focus on research or public policy as it relates to school leadership.



More Reading

To learn more about teacher certification,

1/20/15
check out our book
Cracking the Praxis,
2nd Edition.

Post-secondary teachers require a PhD or the terminal degree in the field in which they want to teach (for example, an MFA to teach arts and music at the post-secondary level). See also the Humanities and Cultures chapter for more information on many post-secondary fields.

Quick Snapshot: Education and Teaching

SAMPLE DEGREE PROGRAM	NO. OF SCHOOLS OFFERING PROGRAM	DEGREE OPTIONS	APPLICATION CONSIDERATIONS (*required or recommended)
Art Teacher Education	Master's: 145 Doctorate: 27	MA PhD	Prior coursework or other formal training in fine or studio arts.
Bilingual and Multilingual Education	Master's: 68 Doctorate: 6	MA, MS, MEd, MBE, PhD	Proven proficiency in a second language
Early Childhood Education and Teaching	Master's: 211 Doctorate: 35	MA, MAT, MS PhD	Teaching experience and certification
Education Leadership and Administration	Master's: 611 Doctorate: 304	MA, EdS PhD	Teaching or administrative credential, plus two years professional experience
Elementary Education and Teaching	Master's: 480 Doctorate: 119	MS, MA, MEd PhD	Valid state teaching credential and teaching experience
Secondary Education and Teaching	Master's: 387 Doctorate: 76	MS, MA, MEd PhD	Major in education or in the subject matter one plans to teach
Special Education	Master's: 541 Doctorate: 136	MS, MEd PhD	Major or some coursework in education or special education

You can find more detailed information to guide you on the right path from these trade organization websites.

TRADE ORGANIZATIONS YOU SHOULD KNOW

School Superintendents Association (AASA)

AASA is a national association of professional educational leaders.

aasa.org

Their website contains a job board, industry related articles, membership information, and links to state associations.

National Association for Bilingual Education (NABE)

nabe.org

Professional association for bilingual educators. Site has information about the field and a great page of links to related sites.

National Association of State Boards of Education
nasbe.org

The National Association of State Boards of Education will help you find information about state-specific school districts including links about certification requirements, teaching standards, and a

	section on early childhood education.
National Science Teachers Association nsta.org	The National Science Teacher Association is a national organization of science teachers. Check their web site for information on conferences, news, publications, and other education resources.
United States Department of Education ed.gov	Information about No Child Left Behind and other federal programs on education.

Typical Admissions Requirements

Students applying to education and teaching programs typically have several years of teaching or administration experience along with a valid teaching credential. However, some master's level programs will include a certification component for students interested in entering the education field without prior experience or certification.

General graduate school requirements:

- Bachelor's degree from an accredited college or university
- Official transcript(s) from all colleges or universities attended

- GRE General Test scores (different programs require different minimum scores)
- TOEFL score (if necessary)
- Academic letters of recommendation
- Letter of intent or statement of purpose
- Application forms
- Application fee

Some degree programs will also require:

- Interview
- Miller Analogies Test (MAT)
- Portfolio (Arts Education)

ENGINEERING

Engineering is a long-respected field leading to many challenging and exciting careers that draw upon creativity, innovative thinking, and a strong foundation in math and science. Engineers are the link between scientific discovery and the commercial application and production of those innovations in society.

There are over 1.2 million engineers employed in the United States, with 11 percent growth expected through 2020. All advanced degrees conferred grew 24 percent through 2010-11, as PhDs saw almost 16 percent growth. With ancient roots dating back to the building of the pyramids, modern engineering trends show a dramatic increase in biomedical engineering as well as higher

demand for infrastructure projects to preserve aging buildings, bridges, and transportation systems. Electrical engineering programs are the largest, with nearly a third of all engineering student enrollment.

Degrees Offered

Engineering offers a wide range of degree programs, each of which contains many concentrations for specialization. For example, a civil engineer could specialize in construction, hydrosystems, structural, or transportation engineering.

Most master's programs are 1-2 years in length. While not all programs require a relevant bachelor's degree, they do require a strong background in math, science, and engineering undergraduate courses. For those interested in research or academia, further

study is required for a Doctorate in Engineering. An alternative to the PhD is a Doctor of Engineering Science (EngScD).

Quick Snapshot: Engineering

SAMPLE DEGREE PROGRAM	NO. OF SCHOOLS OFFERING PROGRAM	% OF ENGINEERING ENROLLMENT*	% OF ENGINEERING EMPLOYMENT **	SPECIAL APPLICATION NOTES
Aerospace	Master's: 84 Doctorate: 42	4%	4%	BS aerospace engineering or significant math and engineering coursework
Biomedical	Master's: 165 Doctorate: 112	6%	1%	
Chemical	Master's: 205 Doctorate: 121	6%	2%	
Civil	Master's: 231 Doctorate: 119	13%	17%	Very competitive admission. Strong scores in engineering, math & science undergraduate courses.
Electrical, Electronics	Master's: 284 Doctorate: 151	28%	19%	BS electrical engineering or related field, minimum 3.0 GPA
Materials & Engineering	Master's: 119 Doctorate: 70	4%	15%	BS in related field or significant coursework in math and science
Mechanical	Master's: 273 Doctorate: 135	15%	15%	BS in engineering or related subject; minimum GPA; math & science pre-requisites

*National Center for Education Statistics, 2007-8. Materials Science & Engineering statistic combines Manufacturing/Industrial/Metallurgical/Materials numbers.

**Bureau of Labor and Statistics, Occupational Outlook Handbook, 2010-11.

You can find more detailed information to guide you on the right path from these trade organization websites.

TRADE ORGANIZATIONS YOU SHOULD KNOW

National Society of Professional Engineers
nspe.org

The National Society of Professional Engineers has the scoop on all the latest technologies and licensing regulations.

American Engineering Association
aea.org

The American Engineering Association provides a support system for all engineers. Included on the site are links to information for computer and electrical engineers.

American Society of Civil Engineers
asce.org

The American Society of Civil Engineers is the best clearing house for the field. This is the place to look for news, jobs, and licensing information.

Institute of Electrical and Electronics Engineers
ieee.org

IEEE is the most complete site dealing specifically with electrical engineering. It also contains job information, interesting articles on the field, and even a virtual museum.

ASME
asme.org

An excellent resource for both experienced workers and newcomers to the field. They have a very thorough Career & Education section.

NASA (National
Aeronautics
and Space
Administration)
nasa.gov

The site includes recent news about NASA and its accomplishments.

Typical Admissions Requirements

Most graduate engineering programs look for substantial coursework in math and science at the undergraduate level, and some require specific classes or majors within the field. Be sure to carefully review admissions requirements well in advance so you can meet all requirements before you apply. Depending on the program, schools might require a minimum GPA.

General graduate school requirements:

- Bachelor's degree from an accredited college or university
- Official transcript(s) from all colleges or universities attended
- GRE General Test scores (different programs require different minimum scores)
- TOEFL score (if necessary)
- Letters of recommendation
- Application forms
- Application fee

Some degree programs will also require:

- Interview
- Letter of intent or statement of purpose
- Supplementary Essays

ENVIRONMENTAL SCIENCE, NATURAL RESOURCE MANAGEMENT, CONSERVATION, AND SUSTAINABILITY

As green issues grow in momentum, popularity, and sometimes controversy, the professional fields that employ environmental scientists, conservationists, and natural resource managers are trending upward as these issues take more of the spotlight.

In fact, the National Center for Education Statistics did not even track graduate enrollment in natural resources and conservation in the mid 1990s, but reported 13,000 graduate enrollees as of 2007-08. The Bureau of Labor and Statistics began tracking “Green

Goods and Services” in 2010 in an attempt to quantify and track this blossoming trend that impacts jobs in the United States.

Whether driven by the science behind these issues or the laws and policies (informed by the science and social issues) that impact the environment, people enter this field to make a difference and help keep our planet in good shape for the next generation. Many schools create Interdisciplinary programs to encompass the various subjects that impact this field; one might take courses across departments of biology, law, anthropology, sociology, and business or economics. In addition, graduates students can specialize in their particular area of interest, whether more focused on wildlife, water, forestry, land-use, etc.

In general, environmental science takes a more scientific, research-based approach to

the problems while environmental studies encompasses the social, historical, political, and legal aspects of the field, with a foundation in scientific data. Be sure to research a specific school's program description and curriculum, as environmental studies is open to interpretation by a school's faculty and departments. If your interest area is specific to forestry, flora and fauna (wildlands), fisheries and aquatic life, or mammals (wildlife), there are master's and PhD programs for these subject areas. Also, think about your geography, as your fieldwork can be greatly enhanced by the location of your graduate program.

Degrees Offered

While there are opportunities for those with bachelor's degrees to work in this field, master's degrees provide opportunities for

advancement and management positions including leading research teams or controlling the direction of projects. Master's degree programs also give students an opportunity to research an area in depth with scientific method, fieldwork, and a broad spectrum of the various ways to address an environmental issue, like the laws and policies that impact this discipline. Of course, a PhD is required for some teaching, research or senior positions at policy institutes and government agencies.

When choosing your degree program, consider whether you want a broad approach to natural sciences with a specific focus area or would prefer a scientific approach within your area of focus.

MA or MS in Environmental Studies/Science

PhD in Environmental Studies/Science

Master of Forestry, MS or PhD Forestry

MS or PhD Natural Resources Management and Policy

MS or PhD Wildlife or Wildlands Science and Management

Quick Snapshot: Environmental Sciences

SAMPLE DEGREE PROGRAM	NO. OF SCHOOLS OFFERING PROGRAM	DEGREE OPTIONS	PROGRAM CONSIDERATIONS
Environmental Science	Master's: 92 Doctorate: 49	MA, MS PhD	Some schools offer thesis and non-thesis options. Also consider broader study versus an area of focus, like water, animals, land, etc.
Environmental Studies	Master's: 55 Doctorate: 20	MA, MS PhD	This discipline provides a broader approach to the issues, covering the environment including social, political, historical, scientific, etc.
Forest Sciences	Master's: 43 Doctorate: 34	MFR, MS PhD	Master of Science and PhD degrees are more research-oriented than the Master of Forestry degree.
Natural Resources Management and Policy	Master's: 46 Doctorate: 28	MS, JD/MS PhD	Check for interdisciplinary programs or joint degree programs in law or business to tailor your focus.
Wildlife and Wildlands Science	Master's: 30 Doctorate: 24	MS PhD	Applicants should have undergraduate coursework/major in biology or related sciences.

You can find more detailed information to guide you on the right path from these trade organization websites.

TRADE ORGANIZATIONS YOU SHOULD KNOW

Joint Forestry Team
jointforestryteam.org

Different organizations join resources to make recommendations that result in coordinated inter-agency delivery of forestry and conservation assistance for working forests, farms, and ranches: USDA-National Resources Conservation Service (NRCS), the

National Association of State Foresters (NASF), the National Association of Conservation Districts (NACD), and the USDA Forest Service (USFS).

National Audubon Society
audubon.org

For more than a century, the Audubon Society has been committed to conserving and restoring natural ecosystems, particularly for birds and wildlife.

Natural Resources Conservation Service
nrcs.usda.gov

Established by Congress in 1935 as the Soil

Conservation Service, this agency's name was changed in 1994 to reflect its broadening scope.

League of Conservation Voters
lcv.org

A national non-profit that works to keep environmental issues as national priorities, often through grass-roots campaigning, awareness, and education.

Typical Admissions Requirements

Depending on your area of focus, programs may look for a variety of coursework, including anthropology, biology, sociology and more. Undergraduate GPA, recommendations, essays, and GRE scores are required. While undergraduate prerequisites vary, some programs look for an undergraduate degree in a field such as the natural sciences, social sciences, or engineering. For students pursuing subject matter related to policy or economics, schools will look for relevant majors/coursework in those areas.

General graduate school requirements:

- Bachelor's degree from an accredited college or university

- Official transcript(s) from all colleges or universities attended
- GRE General Test scores (different programs require different minimum scores)
- TOEFL score (if necessary)
- Letters of recommendation
- Letter of intent or statement of purpose
- Application forms
- Application fee

Some degree programs schools also require:

Specific coursework in a related field. Some schools give conditional acceptance until students earn credits for a specific area that is lacking.

HEALTH CARE AND PUBLIC HEALTH

The field of health care is experiencing explosive growth due to the growing elderly population and technological advances in the treatment and diagnosis of illness, disease, injury, and other physical and mental impairments. With a fantastic job outlook, all graduate degrees conferred grew 40 percent in five years (from 2005-06 to 2010-2011). Many careers in this field require advanced education and/or specialization, and the number of advanced degrees conferred mirrors the growth pattern in this industry, with a 47 percent increase in Master's degrees and 32% increase in PhD's conferred (from 2005-06 to 2010-2011).

Degrees Offered in Health Care and Public Health

Graduate degrees in health care or public health are required for many careers in this field. For audiologists, speech pathologists, occupational or physical therapists, and many other health careers, a master's degree or professional degree prepares you for work with patients whether in hospitals, clinics, ambulatory care centers, or physicians' offices. Some nurses and public health graduates interested in administration or management pursue joint degrees, such as a joint MBA program.

Growth in the health care industry is evidenced by the dramatic growth seen in advanced degrees conferred. Particularly notable is the rise in the number of doctorates or professional degrees, which grew to over 60,000 in 2011.



Further Reading

Are you thinking about taking the MCAT? Prepare with some of our fantastic MCAT review products: *Complete MCAT 2015 Anatomy Flashcards* Our series of MCAT Review books by subject (collect all 6!)

Some master's degree programs are coupled with undergraduate programs while others allow you to enter without a specific bachelor's degree as long as you meet prerequisites. Some examples include Master of Science in Nursing, Master in Public Health or Master of Science in Public Health, Master of Science in Physical Therapy, etc. Another

possible career path in health care is the Doctor of Medicine (MD) and the Doctor of Osteopathic Medicine (DO). Admission to these programs is very competitive and it's worth noting that admission requires a strong background in sciences and math as well as solid MCAT scores.

Quick Snapshot: Health Care & Public Health

SAMPLE DEGREE PROGRAM	NO. OF SCHOOLS OFFERING PROGRAM	DEGREE OPTIONS	APPLICATION CONSIDERATIONS (*required or recommended)
Audiology	Master's: 107 Doctorate: 81	MA, MS PhD	Credits in biology, physical science, mathematics, behavioral or social sciences, and speech and language development
Family Nurse Practitioner Studies	Master's: 135 Doctorate: 30	MS PhD	Solid background in physics and mathematics
Health Services, Hospital Management	Master's: 142 Doctorate: 122	MHA, MPH, MBA PhD	Some work experience; background in statistics, accounting or economics
Nursing Administration	Master's: 109 Doctorate: 33	MS PhD	Background in chemistry, physics, calculus; Specific pre-req's based on area of focus
Occupational Therapy	Master's: 88 Doctorate: 78	MS PhD	Physics major* GRE Subject Test in Physics*
Physical Therapy	Master's: 143 Doctorate: 90	MPT, DPT, MS PhD, Ed D	BS PT or relevant coursework
Public Health	Master's: 133 Doctorate: 112	MPH, DPH Joint Degrees (MD, MPH, RN)	College-level math or biostatistics and the sciences*

You can find more detailed information to guide you on the right path from these trade organization websites.

TRADE ORGANIZATIONS YOU SHOULD KNOW

American Association of Nurse Practitioners

aanp.org

The American Association of Nurse Practitioners is an advocacy and policy oriented organization of nurse practitioners.

American College of Epidemiology
acepidemiology.org

The American College of Epidemiology is a professional organization dedicated to continued education for epidemiologists and their

	activities, and message boards.
--	---------------------------------

Typical Admissions Requirements

Requirements vary depending on the program you wish to pursue—be sure to read about specific prerequisites for the schools on your list. Most professions in this field need majors or coursework in the sciences and statistics while business and economics are common admissions requirements for managerial positions.

Trends in Health Care and Public Health

Technological advances in healthcare mean more options for treating illnesses and diseases. Coupled with an increased emphasis on preventative care, this will drive demand for more nurses, already the largest healthcare occupation at 2.7 million.

Hospitals are one of the largest employers of healthcare workers; despite this, hospitals will see a slower rate of new jobs because clinics and other outpatient care sites are growing in use.

Ten of the top twenty fastest growing occupations (across all occupations) are healthcare related, meaning that the industry as a whole should see 26 percent growth in jobs through 2020.

The aging baby boom population will increase demand in specialties like occupational therapy, physical therapy, audiology, and speech pathology.

HUMANITIES AND CULTURES

Socrates taught the adage “Know thyself.” Our need to find meaning and connect with one another runs deep in our humanity. The various degree areas of focus in the humanities and cultures provide a context that allows us to better understand “who we are” through the study of literature, culture, gender or ethnic identity, philosophy, religion, and even the very languages we speak. The analytical thinking and writing skills required for many of these disciplines translate well to many jobs in our modern economy.

Post-secondary teaching and writing opportunities show solid competition for jobs, but job outlook remains fair depending on the area pursued. Growth in advanced degrees

has slowed to 6 percent in the past 5 years (from 2005-06 to 2010-2011). Overall growth in advanced degrees conferred shows a big jump in philosophy and religious studies (39 percent), while English language and literatures and liberal arts have seen more tempered growth at 7 and 8 percent respectively.

Quick Snapshot: Humanities & Cultures

SAMPLE DEGREE PROGRAM	NO. OF SCHOOLS OFFERING PROGRAM	DEGREE OPTIONS	APPLICATION CONSIDERATIONS (*required or recommended)
American Studies	Master's: 50 Doctorate: 22	MA PhD	Background coursework or undergraduate major
Creative Writing	Master's: 158 Doctorate: 41	MA, MFA PhD	High grades in previous creative writing courses*; manuscript in area of focus
English Language and Literature	Master's: 412 Doctorate: 199	MA PhD	GRE Subject Test in Literature in English*; foreign language
Liberal Arts & Sciences, General Studies, Humanities	Master's: 234 Doctorate: 61	MA, MS PhD	Background coursework or undergraduate major
Linguistics	Master's: 94 Doctorate: 57	MA, MS PhD	Writing sample, curriculum vitae
Philosophy, Philosophy & Religion	Master's: 184 Doctorate: 110	MA, MTA/MTS MDiv/Mphil, PhD	Relevant coursework or major recommended

Degrees Offered in Humanities and Cultures

Most master's degree programs in humanities and cultures take 1-2 years to complete, with a culminating thesis and exams. This is true for creative writing, but students also have the option to pursue a Master of Fine Arts, which usually takes two to four years and typically requires a manuscript of publishable quality to complete the program.

Those who choose to go on to pursue a PhD can expect to spend five to seven years fulfilling course requirements, writing a thesis and ultimately, defending it orally. Many PhD programs also have written exam requirements. For degrees in comparative literature and even other areas of literature, there are also foreign language requirements.

A master's level (MA or MS) degree in linguistics covers core areas of language structure, field methods and research. Programs may be class-based or thesis-based; most take about two years. A PhD in linguistics may take an additional three to four years. Most doctoral programs encompass master's level material but focus on theoretical topics in language structure, language acquisition, and processing.

You can find more detailed information to guide you on the right path from these trade organization websites.

TRADE ORGANIZATIONS YOU SHOULD KNOW

American
Academy of
Religion
aarweb.org

The world's largest organization of academics researching and teaching religion-related topics.

American
Comparative
Literature
Association
acla.org

Provides links to journals, prizes, conferences, and also to affiliated associations and research sources.

Linguistic
Society of
America
lsadc.org

This is the largest linguistic society in the world; an interest in the field is the only requirement for membership. In addition to a regularly published journal, *Language*, the LSA hosts annual meetings and summer institutes

The Modern
Language As-
sociation of
America
mla.org

Information on periodicals, conferences, readings, jobs, and style guides. It also provides a quarterly newsletter and links to accredited universities.

The Voice of
the Shuttle
vos.ucsb.edu

An online compendium of sites for academic research. It contains searchable areas from multiple disciplines in the humanities.

Typical Admissions Requirements

Admissions requirements vary across the broad spectrum of programs within humanities and cultures, but most programs require excellent writing skills, so essays, statement of purpose, and/or academic writing samples will often be required as part of the admissions process. For American or English literature as well as comparative literature, be ready to take the GRE Subject Test in Literature in English in addition to the GRE.

General graduate school requirements:

- Bachelor's degree from an accredited college or university
- Official transcript(s) from all colleges or universities attended
- GRE General Test scores (different programs require different minimum scores)
- TOEFL score (if necessary)
- Academic letters of recommendation
- Letter of intent or statement of purpose, essays
- Application forms
- Application fee

Some degree programs will also require:

- Curriculum vitae
- GRE Subject Test: Literature in English
- Academic writing samples



Further Reading

Check out *Cracking the GRE Literature in English Subject Test, 6th Edition* from The Princeton Review.

MATHEMATICS AND STATISTICS

Mathematics is a unique field that requires more than just a mastery of existing techniques and theories; it actually gives mathematicians the opportunity to discern the need for and test the creation of new theories.

The advanced study of mathematics and statistics develops problem solving and critical thinking skills that are sought after and applied in many different career paths. An advanced degree in mathematics or statistics is required for university-level teaching and advanced research.

When looking for graduate programs, know that academic institutions vary the way they

structure their programs and departments. Some statistics departments are housed within the mathematics department while others are separate. Some schools break out applied mathematics to differentiate it from “pure” mathematics. While not all professionals agree on the exact distinctions, applied math generally refers to the mathematical methods used in specific areas such as business, science and engineering, or industries like insurance, healthcare, and finance. Applied math often results in the development of new mathematical models, which are in turn studied in pure mathematics, which covers more theory and generalities.

As a pure mathematician, career opportunities are more competitive unless the degree is coupled with an area of industry focus. Some careers that benefit from advanced math and stats knowledge are physics, actuarial science, biostatistics, engineering, operations

research, computer science, marketing, business and industrial management, economics, finance, chemistry, geology, life sciences, behavioral sciences, and many other fields.

Quick Snapshot: Mathematics and Statistics

SAMPLE DEGREE PROGRAM	NO. OF SCHOOLS OFFERING PROGRAM	DEGREE OPTIONS	APPLICATION CONSIDERATIONS
Applied Mathematics	Master's: 90 Doctorate: 77	MA, MS PhD	Recommend background in linear algebra, real analysis, probability or statistics, theoretical computer science.
Computational Mathematics	Master's: 13 Doctorate: 4	MS PhD	Often combined with applied mathematics, heavy focus on developing computer models.
Mathematics, General	Master's: 254 Doctorate: 250	MA, MS PhD	Math background, incl. Abstract Algebra and Advanced Calculus. Some have minimum GPA requirements.
Statistics, General	Master's: 104 Doctorate: 108	MS PhD	Pre-requisites include Calculus, Linear Algebra, Statistics, and knowledge of a programming language.

Degrees Offered in Mathematics and Statistics

Master's degrees can be pursued on their own, but are also pursued by doctoral candidates in other related fields such as computer science, engineering fields, physics, business, finance, etc. Schools often have thesis and non-thesis options, which in some cases means the MA option is non-thesis and the MS option is thesis track, but this is not always the case. Other schools track the MA option for secondary school or community college-level teaching, but again, programs vary. Read the department descriptions about each option to see how it best fits to your intended career path.

MS or MA Mathematics (12-24 months)

MS or MA Applied Mathematics (12-24 months)

MS or MA Statistics (12-24 months)

PhD Mathematics (4-6 years)

PhD Statistics (4-6 years)

The PhD track is best suited for teaching and research at the university level, or for quantitative research and development in industry or government.

TRADE ORGANIZATIONS YOU SHOULD KNOW

American
Mathematical
Society
(AMS)
ams.org

A rich resource for news and events, publications, jobs, and research (as you might expect, AMS has lots of data and statistics on education and careers in mathematics).

American
Statistical
Association
amstat.org

The world's largest community of statisticians provides resources, news and events, career information, and even scholarships and grants for statisticians worldwide.

Data.gov

A website run by the federal government, whose goal is to make executive branch data sets accessible and available to the public. Among other things, it encourages app development, and community interaction by area, such as Energy or Health.

Society for
Industrial
and Applied
Mathematics

SIAM's mission is to build cooperation between mathematics and the worlds of science and

siam.org

technology through publications, research, and community.

Typical Admissions Requirements

- Minimum GPA
- Major in math, statistics, or related area with a background in calculus (multivariate, probability) and linear algebra.

Some programs require the GRE Subject Test in Mathematics.

Some graduate programs in mathematics (typically pure math PhD track) have a foreign language requirement, particularly in French, Russian, or German. Many

programs require knowledge of a programming language.

General Graduate School Requirements

- Bachelor's degree from an accredited college or university
- Official transcript(s) from all colleges or universities attended
- GRE General Test scores* (different programs require different minimum scores)
- TOEFL score (if necessary)
- Letters of recommendation
- Letter of intent or statement of purpose

- Writing samples
- Application forms
- Application fee

*Not required for all programs

PHYSICAL & EARTH SCIENCES

A highly analytical and research-intensive area, the physical and earth sciences attempt to understand the universe and everything in it: the earth's atmosphere, the earth itself and its oceans, right on down to subatomic particles.

To observe, measure, interpret and develop theories, the understanding and use of mathematics is a critical component to these sciences. Knowledge gained in research is used to design new technologies. Many of these scientists opt to apply their skills in engineering.

For most jobs in physical and earth sciences, an advanced degree is required. Enrollment,

as well as the number of degrees conferred, has shown consistent growth to fill these jobs. Projected job growth is forecasted to average 11 percent in all areas (2010-2020 projection), but closer examination shows more competition in areas like chemistry (the largest field in the group), and very good job opportunities in hydrology and geosciences. Funds from the federal government are helping to boost job growth in the physical sciences as well. In 2007, Congress passed the America COMPETES Act (reauthorized by Congress in 2010), which funds government agencies employing physical scientists to boost the nation's standing in technology and innovation.

Quick Snapshot: Physical & Earth Sciences

SAMPLE DEGREE PROGRAM	NO. OF SCHOOLS OFFERING PROGRAM	DEGREE OPTIONS	APPLICATION CONSIDERATIONS (*required or recommended)
Astronomy	Master's: 34 Doctorate: 26	MS PhD	Astronomy major or strong background in physics*
Chemistry	Master's: 322 Doctorate: 217	MS PhD	Chemistry major* GRE Subject Test in Chemistry
Geological and Earth Sciences	Master's: 193 Doctorate: 129	MS PhD	Background in chemistry, physics, calculus; specific pre-reqs based on area of focus
Physics	Master's: 260 Doctorate: 180	MS PhD	Physics major,* GRE Subject Test in Physics

Typical Admissions Requirements

Without an undergraduate degree in the same field, which many programs will require, a strong background in the physical sciences and mathematics will be preferred, as well as the best preparation for graduate school. In addition to the GRE, schools may require the GRE subject test in Chemistry or Physics.

Given the research-oriented nature of a graduate degree in physical sciences, be sure to do your homework about the areas of research among the faculty, so you can tailor your letter of intent or statement of purpose to the research or specialty you want to pursue in graduate school.

TRADE ORGANIZATIONS YOU SHOULD KNOW

American
Chemical
Society
acs.org

Publishes numerous scientific journals and databases, convenes major research conferences and provides educational, science policy and career programs in chemistry. Also grants more than \$22 million in funds for basic research.

American Institute of Hydrology
aihydrology.org

Establishes the standards for the certification of hydrologists, encompasses both student and professional chapters.

American Institute of Physics
aip.org

Umbrella society for physicists and astronomers, students, and teachers of those subjects. Publishes journals, and website lists valuable resources and job postings.

American Meteorology Society
ametsoc.org

Provides certification, as well as a wealth of information about the field including job postings and grants.

American Physical Society

Second largest organization of physicists that hosts meetings,

aps.org

publishes journals, and provides career information through their website.

General graduate school requirements:

- Bachelor's degree from an accredited college or university
- Official transcript(s) from all colleges or universities attended
- GRE General Test scores (different programs require different minimum scores)
- TOEFL score (if necessary)
- Academic letters of recommendation

-
- Letter of intent or statement of purpose
 - Application forms
 - Application fee

Some degree programs will also require:

- GRE Subject Test: Chemistry
- GRE Subject Test: Physics
- Interview or campus visit
- Relevant work experience

PSYCHOLOGY

Psychology is a science that attempts to better understand mental processes and predict human behavior through careful observation, study and research. It is a popular field with many areas of focus, from industrial and organizational (that applies the principles of psychology in the workplace) to clinical or counseling psychology, where one can focus on children, families, or senior citizens, to name a few.

In general, those interested in psychology follow either a research/teaching track or a counseling track. Psychologists work in schools, hospitals and assisted living centers, and teach or conduct research in schools, colleges, and universities.

About 34 percent of all psychologists are self-employed. In a field that has limited job prospects for those with a bachelor's degree, competition for admission to graduate programs is high. Those with a doctoral degree will find the best job prospects in the field, particularly with a focus in a sub-field such as health. For those seeking a master's degree, job prospects are best in industrial-organizational psychology. Though the job outlook for psychology is good, the number of advanced degrees conferred is growing rapidly at 25 percent (2005-06 to 2010-11).

Be sure to consider all the possible paths to reach your goals, such as Doctor of Medicine in Psychiatry, a Master's in Social Work for counseling, or pursuing an advanced degree in education with certification in counseling.

Degrees Offered in Psychology

Students in clinical psychology who wish for a practitioner-based degree with less focus on research can pursue the PsyD (Doctor of Psychology), while students with more research-focused or teaching interests can pursue a PhD in many of the fields of psychology. Both degrees take around five years to complete and are highly competitive. Some students choose to pursue their clinical psychology interests by earning a Master's in Social Work (MSW). Social workers are licensed after completing their MSW program from a Council on Social Work Education (CSWE) accredited program (usually about two years long) and passing their state's Association of Social Work Boards exam. Students should think carefully about their interests and career goals before selecting a program.

Students can also earn a terminal MS degree in their respective field of psychology (clinical, school, etc.), usually within two to three years; however as with most professions, the higher you go, the more careers open up to you. Graduate work in counseling psychology usually culminates in either a PhD or an EdD, both of which take around five years to complete. The PhD is more research-intensive than the EdD, and both are slightly less academically rigorous than the PhD or PsyD in clinical psychology.

For school psychology the minimum required degree tends to be a master's from a state-approved, two-year school psychology program with at least one year of internship experience. Many states require a more research-heavy Educational Specialist (EdS) degree, and a good number of school psychologists also hold doctorate degrees.

Quick Snapshot: Psychology

SAMPLE DEGREE PROGRAM	NO. OF SCHOOLS OFFERING PROGRAM	% OF EMPLOYMENT **	SPECIAL APPLICATION NOTES
Clinical Psychology	Master's: 156 Doctorate: 114	89%	Coursework in natural or social sciences; GRE Subject Test: Psychology
Counseling Psychology	Master's: 226 Doctorate: 92	See Clinical	Coursework in natural or social sciences a bonus.
Developmental and Child Psychology	Master's: 29 Doctorate: 14	9%	Coursework in psychology often required
Educational Psychology	Master's: 100 Doctorate: 70	See Developmental	College coursework in statistics, education & developmental psychology
Experimental Psychology	Master's: 40 Doctorate: 20	See Developmental	
Industrial and Organizational Psychology	Master's: 68 Doctorate: 30	1%	Psychology major or coursework required
School Psychology	Master's: 144 Doctorate: 73	See Clinical	Psychology and education background a bonus, but not required
Social Psychology	Master's: 25 Doctorate: 13	See Developmental	

You can find more detailed information to guide you on the right path from these trade organization websites.

TRADE ORGANIZATIONS YOU SHOULD KNOW

American Psychological Association

apa.org

The American Psychological Association offers information on all areas within the field.

Association for Psychological Science

psychologicalscience.org

The Association for Psychological Science publishes news, research, and journals and promotes scientific research within the field of psychology.

American Counseling Association

counseling.org

The American Counseling Association offers information on all areas within

	<p>the field, including information on state certification.</p>
<p>National Association of School Psychologists (NASP) nasponline.org</p>	<p>Official website of the NASP, dedicated to sharing resources, studies, and strategies in order to help the public and policymakers recognize the effects of students' mental health on their development, as well as the importance of</p>

	school psychological services.
Association of State and Provincial Psychology Boards asppb.org	Contains information about state licensing requirements.

General graduate school requirements:

- Bachelor's degree from an accredited college or university
- Official transcript(s) from all colleges or universities attended
- GRE General Test scores (different programs require different minimum scores)

- TOEFL score (if necessary)
- Academic letters of recommendation
- Letter of intent or statement of purpose
- Application forms
- Application fee

Some degree programs will also require:

- GRE Subject Test: Psychology
- Interview

PUBLIC AFFAIRS AND POLICY

Public affairs is an umbrella that unites public policy and public administration, drawing upon the fields of political science and economics, to promote and advance policies and solutions that seek to address the public good. For those that like to keep their opinions to themselves, note that public administration is considered a non-partisan environment focused on method and historical context. Public policy discussions, on the other hand, are inherently partisan, as those involved seek to advance their agenda and view of the world as the 'rule of the day.'

Job outlook is good, and the number of advanced degrees is growing faster than projected job growth. Historically, advanced

degrees led to government jobs, but many graduates now work in think tanks, as lobbyists, in academia, for unions or labor relations groups, and in other non-profit and community organizations. Given the economic crises faced by many state and local governments (which employ about 8.3 million people), be sure to keep options open when seeking employment, especially considering the growing popularity of the field. Advanced degrees conferred has grown by 26 percent in just five years (2005-06 to 2010-11).

Quick Snapshot: Public Affairs & Policy

SAMPLE DEGREE PROGRAM	NO. OF SCHOOLS OFFERING PROGRAM	DEGREE OPTIONS	SPECIAL APPLICATION NOTES
Public Administration	Master's: 164 Doctorate: 176	MPA PhD (rare)	Previous work experience sometimes required.
Public Policy/ Analysis	Master's: 68 Doctorate: 56	MPA PhD (rare)	Coursework in in economics, statistics, or college-level math helpful.

TRADE ORGANIZATIONS YOU SHOULD KNOW

American Society for Public Administration
aspanet.org

The American Society for Public Administration has a wealth of information on everything from the latest policy-making decision and resource centers to job listings.

Association for Public Policy Analysis and Management
appam.org

The Association for Public Policy Analysis and Management has information on conferences, internships, educational programs, jobs, joint degrees, and awards.

National Academy for Public Administration

The National Academy for Public Administration is committed to monitoring and

napawash.org	improving governance systems of all kinds.
National Association of Schools of Public Affairs and Administration naspaa.org	Accredits schools of public affairs, including those with dual accreditation. For example, business schools like Willamette University are accredited by both AACSB and NASPAA.

Typical Admissions Requirements

There are no major requirements necessary to apply for advanced degrees in public policy or administration. Many students have at least one year of work experience prior to starting their program. For public policy, helpful background coursework

includes economics, statistics, or college-level math.

General graduate school requirements:

- Bachelor's degree from an accredited college or university
- Official transcript(s) from all colleges or universities attended
- GRE General Test scores (different programs require different minimum scores)
- TOEFL score (if necessary)
- Letters of recommendation
- Letter of intent or statement of purpose

- Application forms
- Application fee

Some degree programs will also require:

- Work experience

SOCIAL SCIENCES

Social sciences encompass the academic study of fields that fall outside of the natural sciences and focus on society, including the study of groups, organizations, institutions, social and economic systems, cultures, and governments. These disciplines adopt scientific method, with both quantitative and qualitative analysis geared to social understanding and improvement.

As globalization creates more complex economies, immigration and social media bring more cultures together, and political systems shift to reflect changes in society, the importance of the social sciences is perhaps greater than ever before.

While the employment outlook for social sciences is competitive in places like history and economics, many social sciences are experiencing much faster than average growth. This is somewhat reflected in the number of candidates receiving an advanced degree, which has grown by 20 percent (2005-06 to 2010-2011).

Quick Snapshot: Social Sciences

SAMPLE DEGREE PROGRAM	NO. OF SCHOOLS OFFERING PROGRAM	DEGREE OPTIONS	SPECIAL APPLICATION NOTES
Anthropology	Master's: 171 Doctorate: 98	MA PhD	Proficiency in at least one foreign language
Economics	Master's: 189 Doctorate: 125	MA, MS PhD	Elementary economics & statistics background
Geography	Master's: 134 Doctorate: 71	MA, MS PhD	Some programs require minimum GPA or GRE
International Relations & Affairs	Master's: 84 Doctorate: 29	MA, MIA, Joint Degrees (Law, Journalism)	Proficiency in foreign language
Political Science and Government	Master's: 223 Doctorate: 136	MA PhD	Political science or government background preferred, but not required
Sociology	Master's: 240 Doctorate: 136	MSoc, MS PhD	Social science majors or some background in sociology or statistics
Social Sciences General	Master's: 83 Doctorate: 24	MSSc PhD	Varies

TRADE ORGANIZATIONS YOU SHOULD KNOW

American Anthropological Association
aaanet.org

The American Anthropological Association has offered anthropology professionals support, information, and services since 1902.

American Planning Association
planning.org

The American Planning Association has advice on planning in urban and rural areas as well as fellowship and conference information.

American Political Science Association
apsanet.org

More than 15,000 members in more than 80 countries share knowledge, professional advice and advancement, and a supportive environment conducive to

	the professional study of politics.
American Sociological Association asanet.org	Information for sociologists, students, and the general public including job opportunities, research grants, and newly-published reports from members.
International Economic Development Council iedconline.org	Offers information and services for those interested in economic development.
International Studies Association isanet.org	The International Studies Association promotes international affairs research and education.

Typical Admissions Requirements

While many advanced degree programs do not require specific majors or coursework, many programs recommend background in the area. In addition, programs like anthropology, international economics, and international relations require foreign language proficiency. For fields involving math and research, some coursework in statistics will be helpful background to your advanced studies as well. When making your Application To Do list or calendar, be sure to note any special application requirements in advance, especially things like work experience or foreign language requirements, though some programs may allow you to study a language while working toward your degree.

General graduate school requirements:

- Bachelor's degree from an accredited college or university
- Official transcript(s) from all colleges or universities attended
- GRE General Test scores (different programs require different minimum scores)
- TOEFL score (if necessary)
- Academic letters of recommendation
- Letter of intent or statement of purpose
- Application forms
- Application fee

Some degree programs will also require:

- Interview
- Relevant work experience
- Supplemental essays or writing sample
- Proficiency in a foreign language

SOCIAL WORK

Social workers collaborate with other human services professionals to look for solutions to the complex problems of modern society. While some social workers opt for counseling or clinical practices, others work in public policy and administration, research, or teaching. Because social workers face society's most challenging problems, working in this vital field takes a lot of effort, a lot of patience, and most of all, lots of passion.

Master's degree programs in social work vary widely in scope and specialty. Some programs focus on methodology and public policy, while others are more clinically focused, preparing professionals for a direct practice in psychotherapy. Still others provide students with the background they

need for a career in public and non-profit social service agencies, or for social planning and social change. When you are choosing a program, it is important to consider where you can get training that is in line with your larger career goals. Upon entering some program, students are required to choose a specialty, such as mental health, employee assistance, aging, health care, corrections, and child welfare.

The job outlook for social workers is good, growing faster than the national average, particularly for those interested in aging populations, rural settings, or working with substance abuse programs. The number of advanced degrees conferred has grown 22 percent in just a few short years between 2006-07 and 2010-11. According to the Council on Social Work Education, women dominate this field, making up about 86 percent of master's degree enrollment, while

historically underrepresented groups comprise just over 30 percent of enrollment.

Quick Snapshot: Social Work

DEGREE PROGRAM	NO. OF SCHOOLS OFFERING PROGRAM	DEGREE OPTIONS	APPLICATION CONSIDERATIONS (*required or recommended)
Clinical Social Work	Master's: 8 Doctorate: 2	CSW PhD	A BSW is not required, but social studies related field is preferred; minimum GPA or GRE score; field work (volunteer or paid)
Social Work/Social Work, Other	Master's: 229 Doctorate: 70	MSW, DSW PhD	BSW applicants may be able to enroll with advanced standing status
Substance Abuse/Addiction Counseling	Master's: 19 Doctorate: 0	MA or MS in Substance Abuse MSW, focus in Substance Abuse	Coursework in psychology or social work helpful; experience in clinical setting (volunteer or paid)

TRADE ORGANIZATIONS YOU SHOULD KNOW

American Board
of Examiners in
Clinical Social
Work
abecsw.org

Features job postings, newsletters, and resources for students of social work.

American Counseling Association
counseling.org

The American Counseling Association offers information on all areas within the field, including information on state certification.

Association of Social Work Boards
aswb.org

A professional association that regulates social work, and develops and maintains the licensing exam.

National Association of Social Workers
socialworkers.org

The largest member organization of professional social workers, offering networking, advocacy, books and journals.

Typical Admissions Requirements

While a BSW is not required for admission to social work programs, some programs allow enrollees with a BSW to receive advanced standing, thereby shortening the amount of fieldwork and coursework you are required to complete.

Many students entering graduate programs in social work have majored in social work, psychology, or public policy. Otherwise, coursework in social and biological sciences will be useful. Some basic knowledge of statistics and research methodologies will also be beneficial to graduate students in social work.

General graduate school requirements:

- Bachelor's degree from an accredited college or university
- Official transcript(s) from all colleges or universities attended
- GRE General Test scores (different programs require different minimum scores)*
- TOEFL score (if necessary)
- Letters of recommendation
- Letter of intent or statement of purpose
- Application forms
- Application fee

*some social work programs accept the Miller Analogy Test in lieu of GRE Scores

Some degree programs will also require:

- Interview
- Work experience (paid or volunteer)

